



Uttar Pradesh Rajarshi Tandon
Open University

UGMM-103

Integral Calculus

BLOCK-1 **03-106**

UNIT-1	Method of integration	05-40
UNIT-2	Reduction Formulas	41-58
UNIT-3	Integration of Rational and Irrational Functions	59-80
UNIT-4	Tangent Normal of the curves	81-106

BLOCK-2 **107-172**

UNIT-5	Tracing of curves	109-132
UNIT-6	Area Under a Curve	133-158
UNIT-7	Volume of a solid of Revolution	159-172

RIL-146

UGMM-103/2



Uttar Pradesh Rajarshi Tandon
Open University

UGMM-103

Integral Calculus

BLOCK

1

INTEGRAL CALCULUS

UNIT 1	05-40
---------------	--------------

Method of integration

UNIT 2	41-58
---------------	--------------

Reeducation Formulas

UNIT 3	59-80
---------------	--------------

Integration of Rational and Irrational Functions

UNIT 4	81-106
---------------	---------------

Tangent Normal of the curves

Curriculum Design Committee

Dr. Ashutosh Gupta, Director, School of Science, UPRTOU, Prayagraj	Coordinator
Prof. Sudhir Kumar Srivastava Dept. of Mathematics, Pt. Deen Dayal Upadhyay University, Gorakhpur	Member
Prof. P.K. Singh Dept. of Mathematics, University of Allahabad, Prayagraj	Member
Prof. Himanshu Pandey Dept. of Mathematics, Pt. Deen Dayal Upadhyay University, Gorakhpur	Member
Dr. Vikash Singh Academic Consultant- Mathematics, School of Science, UPRTOU, Prayagraj.	Member Secretary
Dr. Sankar Saran Tripathi Academic Consultant- Mathematics, School of Science, UPRTOU, Prayagraj	Spl. Invited Member

Course Design Committee

Faculty Members, School of Sciences

Dr. Ashutosh Gupta, Director, School of Science, UPRTOU, Prayagraj.
Dr. Shruti, Asst. Prof. (Statistics), School of Science, UPRTOU, Prayagraj
Dr. Marisha Asst. Prof. (Computer Science), School of Science, UPRTOU, Prayagraj
Mr. Manoj K Balwant Asst. Prof. (Computer Science), School of Science, UPRTOU, Prayagraj
Dr. Dinesh K Gupta Academic Consultant (Chemistry), School of Science, UPRTOU, Prayagraj
Dr. S.S. Tripathi, Academic Consultant (Maths), School of Science, UPRTOU, Prayagraj
Dr. Dharamveer Singh, Academic Consultant (Bio-Chemistry),
School of Science, UPRTOU, Prayagraj
Dr. R.P. Singh, Academic Consultant (Bio-Chemistry), School of Science, UPRTOU, Prayagraj
Dr. Susma Chauhan, Academic Consultant (Botany), School of Science, UPRTOU, Prayagraj
Dr. Deepa Chaubey, Academic Consultant (Zoology), School of Science, UPRTOU, Prayagraj

Course Preparation Committee

Dr. Vikas Singh Dept. of Mathematics Academic Consultant-Mathematics, School of Science, UPRTOU, Prayagraj	(Block-1; Unit-1,2,3,4, and Block-2; Unit-5,6 & 7)	Author
Dr. S.S. Tripathi Academic Consultant-Mathematics, School of Science, JPRTOU, Prayagraj.		Editor
Dr. S.S. Tripathi Academic Consultant-Mathematics, School of Science, UPRTOU, Prayagraj		SLM Coordinator

© UPRTOU, Prayagraj. 2020

ISBN : 978-93-83328-50-5

*All Rights are reserved. No part of this work may be reproduced in any form, by mimeograph or any other means, without permission in writing from the **Uttar Pradesh Rajarshi Tondon Open University, Prayagraj.***

Printed and Published by Dr. Arun Kumar Gupta Registrar, Uttar Pradesh Rajarshi Tandon Open University, 2020.

Printed By : Chandrakala Universal Pvt. Ltd. 42/7 Jawahar Lal Neharu Road, Prayagraj.

211002

UNIT-1

METHODS OF INTEGRATION

Structure

1.1 Introduction

Objective

1.2 Basic Definitions

1.3 Standard Integrals

1.4 Algebra of Integrals

1.5 Integration by Substitution

1.5.1 Method of Substitution

1.5.2 Integrals using Trigonometric formula

1.5.3 Trigonometric and Hyperbolic Substitution

1.6 Two properties of Definite integrals

1.7 Integration by Parts

1.7.1 Evaluation of $\int e^{ax} \sin bx$ and $\int e^{ax} \cos bx$ dx

1.7.2 Evaluation of $\int \sqrt{a^2 - x^2}$ dx, $\int \sqrt{a^2 + x^2}$ dx, and

$$\int \sqrt{x^2 - a^2} dx$$

1.7.3 Evaluation of the type $\int e^{ax} [f(x) + f'(x)] dx$

1.8 Summary

1.9 Terminal Questions/Answers

1.1 Introduction

In this unit we have seen that the definite integral $\int_a^b f(x) dx$ represents the signed area bounded by the curve $y = f(x)$, the x-axis and the lines $x = a$ and $x = b$. The fundamental theorem of Calculus gives us an easy way of evaluating such an integral, by first finding the antiderivative of the given function, whenever it exists. Starting from this unit, we shall study various methods and techniques of integration. In this unit, we shall consider two main methods:

- (1) The method of substitution and
- (2) The method of integration by parts.

Objectives:

After reading this unit we should be able to:

- Define the indefinite integral of a function
- Evaluate certain standard integrals by finding the antiderivatives of the integrands
- Use the rules of the algebra of integrals to evaluate some integrals
- Integrate a product of two functions, by parts.

1.2 Basic Definitions

The anti derivative of a function is not unique. More precisely, we have seen that if a function F is an anti derivative of a function f , then $F+c$ is also an anti derivative of f , where c is any arbitrary constant. Now we shall introduce a notation here. We shall use the symbol $\int f(x) dx$ to denote the class of all anti derivatives of f . We call it the indefinite integral or just the integral of f . You must have noticed that we use the same sign \int here that we have used for definite integrals in Unit 9. Thus, if $F(x)$ is an anti derivative of $f(x)$, then we can write $\int f(x)dx = F(x) + c$

This c is called the constant of integration. As in the case of definite integrals, $f(x)$ is called the integrand and dx indicates that $f(x)$ is integrated with respect to the variable x . For example, in the equation

$$\int (av + b)^4 dv = \frac{(av + b)^5}{5a} + c$$

$(av + b)^4$ is the integrand, v is the variable of integration, and $\frac{(av + b)^5}{5a} + c$ is the integral of the integrand $(av + b)^4$.

You will also agree that the indefinite integral of $\cos x$ is $\sin x + c$, since we know that $\sin x$ is an antiderivative of $\cos x$. Similarly, the indefinite integrals of $\int e^{2x} dx = \frac{1}{2}e^{2x} + c$, and the indefinite integral of

$x^3 + 1$ is $\int (x^3 + 1)dx = \frac{x^4}{4} + x + c$. You have seen in Unit 9 that the

definite integral $\int_a^b f(x) dx$ is a uniquely defined real number whose value depends on a , b and the function f .

On the other hand, the indefinite integral $\int f(x)dx$ is a class of functions which differ from one another by constants. It is not a definite number, it is not even a definite function. We say that the indefinite integral is unique upto an arbitrary constant. Unlike the definite integral which depends on a, b and f, the indefinite integral depends only on f.

All the symbols in the notation $\int_a^b f(x)dx$ for the definite integral have an interpretation.

The symbol \int reminds us of summation, a and b give the limits for x for the summation. And $f(x) dx$ shows that we are not considering the sum of function values multiplied by small increments in the values of x.

In the case of an indefinite integral, however, the notation $\int f(x)dx$ has no similar interpretation. The inspiration for this notation comes from the fundamental theorem of Calculus.

Thus, having defined an indefinite integral, let us get acquainted with the various techniques for evaluating integrals.

1.3 Standard Integrals

Integration would be a fairly simple matter if we had a list of integral formulas, or a table of integrals, in which we could locate any integral that we ever needed to evaluate. But the diversity of integrals that we encounter in practice, makes it impossible to have such a table. One way to overcome this problem is to have a short table of integrals of elementary functions, and learn the techniques by which the range of applicability of this short table can be extended. Accordingly, we build up a table (Table 1) of standard types of integrals formulas by inverting formulas for derivatives, Check the validity of each entry in Table 1, by verifying that the derivative of any integral is the given corresponding function.

Table 1

S.No.	Function	Integral
1.	x^n	$\frac{x^{n+1}}{n+1} + c, n \neq -1$
2.	$\sin x$	$-\cos x + c$
3.	$\cos x$	$\sin x + c$

4.	$\sec^2 x$	$\tan x + c$
5.	$\operatorname{cosec}^2 x$	$-\cot x + c$
6.	$\sec x \tan x$	$\sec x + c$
7.	$\operatorname{Cosec} x \cot x$	$-\operatorname{cosec} x + c$
8.	$\frac{1}{\sqrt{1-x^2}}$	$\sin^{-1} x + c$, or $-\cos^{-1} x + c$
9.	$\frac{1}{1+x^2}$	$-\cot^{-1} x + c$
10.	$\frac{1}{x\sqrt{x^2-1}}$	$\operatorname{Sec}^{-1} x + c$
11.	$\frac{1}{x}$	$\ln x + c$
12.	e^x	$e^x + c$
13.	a^x	$(a^x/\ln a) + c$
14.	$\sinh x$	$\cosh x + c$
15.	$\cosh x$	$\sinh x + c$
16.	$\operatorname{Sech}^2 x$	$\tanh x + c$
17.	$\operatorname{cosech}^2 x$	$-\cot x + c$
18.	$\operatorname{sech} x \tanh x$	$-\operatorname{sech} x + c$
19.	$\operatorname{cosech} x \coth x$	$-\operatorname{cosech} x + c$

1.4 Algebra of Integrals

We are familiar with the rule for differentiation which says

$$\frac{d}{dx}[af(x) + bg(x)] = a \frac{d}{dx}[f(x)] + b \frac{d}{dx}[g(x)]$$

There is a similar rule for integration:

Rule 1: $\int [af(x) + b g(x)]dx = a \int f(x)dx + b \int g(x)dx$

Theorem 1: If f is an integrable function, then so is kf(x) and

$$\int kf(x)dx = k \int f(x)dx$$

Proof: Let $\int kf(x) = F(x) + c$. Then by definition $\frac{d}{dx}[F(x) + c] = f(x)$

$$\begin{aligned} \therefore \frac{d}{dx}[k\{F(x) + c\}] &= kf(x). \text{ Again, by definition, we have } \int kf(x) dx \\ &= k[F(x) + c] \\ &= k \int f(x)dx \end{aligned}$$

Theorem 2: If f and g are two integrable functions, then f+g is integrable, and we have

$$\int [f(x) + g(x)]dx = \int f(x)dx + \int g(x)dx$$

Proof: Let $\int f(x)dx = F(x) + c$. $\int g(x)dx = G(x) + c$

Then, $\frac{d}{dx} [\{F(x) + c\} + \{G(x) + c\}] = f(x) + g(x)$

Rule (1) may be extended to include a finite number of functions, that is, we can write

Rule (2) $\int [k_1f_1(x) + k_2f_2(x) + \dots + k_nf_n(x)]dx$
 $= k_1 \int f_1(x)dx + k_2 \int f_2(x)dx \dots \dots \dots + k_n \int f_n(x)dx$

We can make use of rule (2) to evaluate certain integrals which are not listed in Table 1.

Example 1: Let us evaluate $\int (x + \frac{1}{x})^3 dx$

We know that $(x + \frac{1}{x})^3 = x^3 + 3x + \frac{3}{x} + \frac{1}{x^3}$ therefore

$$\int (x + \frac{1}{x})^3 dx = \int (x^3 + 3x + \frac{3}{x} + \frac{1}{x^3})dx$$

RIL-146

$$= x^3 dx + 3 \int x dx + 3 \int \frac{dx}{x} + \int \frac{dx}{x^3} \quad \dots \text{Rule 2}$$

Using integrals formulas 1 and 11 from Table 1, we have

$$\begin{aligned} \int \left(x + \frac{1}{x}\right)^3 dx &= \left(\frac{x^4}{4} + c_1\right) + 3\left(\frac{x^2}{2} + c_2\right) + 3(\ln|x| + c_3) + \left(\frac{x^{-2}}{-2} + c_4\right) \\ &= \frac{1}{4}x^4 + \frac{3}{2}x^2 + 3\ln|x| - \frac{1}{2x^2} + c \end{aligned}$$

Note that $c_1 + 3c_2 + 3c_3 + c_4$ has been replaced by a single arbitrary constant c .

Example 2: Suppose we want to evaluate $\int (2 + 3 \sin x + 4e^x) dx$

$$\begin{aligned} \text{This integral can be written as } & 2 \int dx + 3 \int \sin x dx + 4 \int e^x dx \\ &= 2x - 3 \cos x + 4e^x + c. \text{ Note that } \int dx = \int 1 dx = \int x^0 dx = x + c \end{aligned}$$

Example 3: To evaluate the definite integral $\int_0^1 (x + 2x^2)^2 dx$,

$$\begin{aligned} \text{Thus, } \int (x + 2x^2)^2 dx &= \int (x^2 + 4x^3 + 4x^4) dx \\ &= \int x^2 dx + 4 \int x^3 dx + 4 \int x^4 dx = \frac{1}{3}x^3 + x^4 + \frac{4}{5}x^5 + c \end{aligned}$$

According to our definition indefinite integral, this gives an antiderivative of

$(x + 2x^2)^2$ for a given value of c . By using the fundamental Theorem of Calculus we can now evaluate the definite integral.

$$\begin{aligned} \int_0^1 (x + 2x^2)^2 dx &= \left(\frac{1}{3}x^3 + x^4 + \frac{4}{5}x^5 + c \right) \Big|_0^1 \\ &= \left(\frac{1}{3} + 1 + \frac{4}{5} + c \right) - c = \frac{32}{15} \end{aligned}$$

Note that for the purpose of evaluating a definite integral, we could take the antiderivative corresponding to $c = 0$, that is,

$$\frac{1}{3}x^3 + x^4 + \frac{4}{5}x^5, \text{ as the constants cancel out.}$$

We could evaluate a number of integrals. But still there are certain integrals like $\int \sin 2x \, dx$ which cannot be evaluated. The method of substitution which we are going to describe in the next section will come in handy in these cases.

1.5 Integration by Substitution

In this section we shall study the first of the main methods of integration dealt with in this unit the method of substitution. This is one of the most commonly used techniques of integration.

1.5.1 Method of Substitution

Theorem 3: If $\int f(v)dv = F(v) + c$, then on substituting $g(x)$ for v , we get

$$\int f[g(x)]g'(x)dx = \int f(v)dv.$$

Proof: We shall make use of the chain rule for derivatives to prove this theorem.

Since $\int f(v)dv = F(v) + c$, we can write $\frac{dF(v)}{dv} = f(v)$. Now if we

write v as a function of x , say $v = g(x)$, then

$$\frac{d}{dx} F[g(x)] = \frac{dF[g(x)]}{dg(x)} \cdot \frac{dg(x)}{dx} \text{ by chain rule}$$

$$= f[g(x)] \cdot \frac{dg(x)}{dx} \text{ since } v = g(x) = f[g(x)] \cdot g'(x)$$

This shows that $F[g(x)]$ is an antiderivative of $f\{g(x)\}g'(x)$. This means that

$$\int f[g(x)]g'(x)dx = F[g(x)] + c = F(v) + c = \int f(v)dv.$$

Evaluate $\int \sin 2x \, dx$, we could take $v = g(x) = 2x$ and get

$$\int \sin 2x \, dx = \frac{1}{2} \int \sin 2x (2) \, dx$$

$$= \frac{1}{2} \int \sin v \, dv, \text{ since } g(x) = 2x \text{ and } g'(x) = 2.$$

$$= \frac{-\cos v}{2} + c = \frac{\cos 2x}{2} + c$$

We make a special mention of the following three cases which follow from theorem 3.

Case (i) if $f(v) = v^n$, $n \neq -1$ and $v = g(x)$, then

$$\int [g(x)]^n g'(x) dx = \frac{[g(x)]^{n+1}}{n+1} + c$$

Case (ii) If $f(v) = 1/v$ and $v = g(x)$.

$$\text{Then by formula } \int \frac{g'(x)}{g(x)} dx = \ln |g(x)| + c$$

Case (iii) $\int f(x) dx = F(x) + c$, then

$$\int_a^b f[g(x)]g'(x) dx = \int_{g(a)}^{g(b)} f(v) dv, \text{ where } v = g(x) \text{ [The limits of}$$

integration are $g(a)$ and $g(b) = F(v) \Big|_{g(a)}^{g(b)}$ Since $x = a \Rightarrow v = g(x) = g(a)$,
and $x = b \Rightarrow g(x) = g(b)$.]

Example 4: Let us integrate $(2x + 1)(x^2 + x + 1)^5$

$$\text{For this we observe that } \frac{d}{dx}(x^2 + x + 1) = 2x + 1$$

Thus, $\int (2x+1)(x^2+x+1)^5 dx$ is of the form $\int [g(x)]^n g'(x) dx$ and hence can be evaluated as in (1) above

$$\text{Therefore, } \int (2x+1)(x^2+x+1)^5 dx = \frac{1}{6} (x^2+x+1)^6 + c$$

Alternatively, to find $\int (2x + 1)(x^2+x+1)^5 dx$ we can substitute x^2+x+1 by u

$$\text{This means } \frac{du}{dx} = 2x + 1.$$

$$\text{Therefore } \int (2x+1)(x^2+x+1)^5 dx = \int u^5 du = \frac{1}{6} (x^2+x+1)^6 + c$$

Example 5: Let us evaluate $\int (ax + b)^n dx$

$$= \int (ax + b)^n dx = \frac{1}{a} \int (ax + b)^n dx.$$

$$\text{Therefore, when } n \neq -1, \int (ax+b)^n dx = \frac{(ax + b)^{n+1}}{a(n+1)}$$

$$\text{And when } n = -1, \int (ax+b)^n dx = \int \frac{dx}{ax + b} = \frac{1}{a} \ln |ax+b| + c$$

Example 6: Suppose we want to evaluate the definite integral

$\int_0^2 \frac{x+1}{x^2+2x+3} dx$. We put $x^2 + 2x + 3 = u$. This implies

$$\frac{du}{dx} = 2(x+1). \text{ Further,}$$

When $x = 0$, $u = 3$, and when $x = 2$, $u = 11$. Thus

$$\int_0^2 \frac{x+1}{x^2+2x+3} dx = \frac{1}{2} \int_0^2 \frac{1}{u} \frac{du}{dx} dx = \frac{1}{2} \int_3^{11} \frac{du}{u} = \frac{1}{2} \ln |u| \Big|_3^{11} = \frac{1}{2} (\ln 11 - \ln 3) = \frac{1}{2} \ln \frac{11}{3}$$

Example 7: To evaluate $\int x e^{2x^2} dx$, we substitute $2x^2 = u$. Since

$$\begin{aligned} \frac{du}{dx} &= 4x, \text{ we can write, } \int x e^{2x^2} dx = \frac{1}{4} \int x^{2x^2} 4x dx = \frac{1}{4} \int e^u \frac{du}{dx} dx \\ &= \frac{1}{4} \int e^u du = \frac{1}{4} e^u + c = \frac{1}{4} x^{2x^2} + c \end{aligned}$$

Check your progress

(1) Write down the integrals of the following

(i) x^4 (ii) $x^{-3/2}$ (iii) $4x^{-2}$ (iv) 3

(a) (i) $1 - 2x + x^2$ (ii) $(x - \frac{1}{2})^2$ (iii) $(1+x)^3$

(b) (i) $e^x + e^{-x} + 4$ (ii) $4\cos x - 3\sin x + e^{x+x}$
(iv) $4\operatorname{sech}^2 x + e^x - 8x$.

(c) (i) $\frac{2}{\sqrt{1-x^2}} + \frac{5}{x}$ (ii) $\frac{2x^2+5}{x^2+1}$

(d) (i) $ax^3 + bx^2 + cx + d$ (ii) $(\sqrt{x} - \frac{1}{\sqrt{x}})^2$

(e) (i) $\frac{\sin^4 x + \cosh 4x}{\sin^2 x \cos^2 x}$ (ii) $(2+x)(3-\sqrt{x})$

(2) Evaluate the following definite integrals

(a) (i) $\int_5^6 x^4 dx$ (ii) $\int_1^2 \frac{1+x}{x^2} dx$

$$(b) (i) \int_2^4 \left(x + \frac{1}{2}\right)^2 dx \quad (ii) \int_0^1 (x+1)^3 dx$$

3) Evaluate

$$(a) \int \sqrt{5x-3} dx \quad (b) \int (2x+1)^6 dx \quad (c) \int_1^3 \frac{dx}{4+5x}$$

$$(d) \int \frac{5dx}{10x+7} \quad (e) \int \frac{x+1}{x^2+2x+7} \quad (f) \int_2^3 \frac{3x^2+2x+1}{x^2+x^2+x-8}$$

$$(g) \int x^{1/3} \sqrt{x^{4/3}-1} dx \quad (h) \int \frac{x dx}{1-3x^2}$$

Example 8: To evaluate $\int \sin ax dx$, we proceeded in the same manner as we did for $\int \sin 2x dx$. We make the substitution $ax = u$

$$\text{This gives } \frac{du}{dx} = a. \text{ Thus, } \int \sin ax dx = \frac{1}{a} \int \sin u \cdot \frac{du}{dx} \cdot dx = \frac{1}{a} \cos ax + c$$

Example 9: Suppose we want to evaluate

$$(i) \int \cot x dx \quad (ii) \int \tan x dx \text{ and } (iii) \int \operatorname{cosec} 2x dx$$

(i) we can write $\int \cot x dx = \int \frac{\cos x}{\sin x} dx$. Now since $\frac{d}{dx} \sin x = \cos x$, this integral falls in the category of case (ii) mentioned earlier, and thus, $\int \cot x dx = \ln |\sin x| + c$

(i) to evaluate $\int \tan x dx$, we write

$$\int \tan x dx = \int \frac{\sec x \tan x}{\sec} dx = \ln |\sec x| + c, \text{ as } \frac{d}{dx} \sec x = \sec x \tan x$$

(iii) to integrate $\operatorname{cosec} 2x$ we write

$$\int \operatorname{cosec} 2x dx = \frac{1}{2} \int \frac{2 \operatorname{cosec} 2x (\operatorname{cosec} 2x - \cot 2x)}{\operatorname{cosec} 2x - \cot 2x} dx$$

$$\text{Here again, } \frac{d}{dx} (\operatorname{cosec} 2x - \cot 2x) = 2 \operatorname{cosec} 2x (\operatorname{cosec} 2x - \cot 2x)$$

$$\text{This means } \int \operatorname{cosec} 2x dx = \frac{1}{2} \ln |\operatorname{cosec} 2x - \cot 2x| + c$$

Example 10: Let us evaluate $\int e^{\sin^2 x} \sin 2x dx$

If we put $\sin^2 x = u$ the $\frac{du}{dx} = 2 \sin x \cos x = \sin 2x$

Therefore, $\int e^{\sin^2 x} \sin 2x \, dx = \int e^u \, du = e^u + c = e^{\sin^2 x} + cx$

1.5.2 Integrals using Trigonometric Formulas

In this section, we shall evaluate integrals with the help of the following

trigonometric formulas $\sin^2 x = \frac{1}{2}(1 - \cos 2x)$,

$$\cos^2 x = \frac{1}{2}(1 + \cos 2x).$$

$$\sin^3 x = \frac{3}{4} \sin x - \frac{1}{4} \sin 3x \quad \cos^3 x = \frac{3}{4} \cos x + \frac{1}{4} \cos 3x$$

$$\sin m x \cos n x = \frac{1}{2} [\sin(m+n)x + \sin(m-n)x], \quad \cos m x \cos n x = \frac{1}{2} [\cos$$

$$(m+n)x + \cos(m-n)x], \quad \sin m x \sin n x = \frac{1}{2} [\cos(m-n)x - \cos(m+n)x]$$

Example 11: To evaluate $\int \cos^3 ax \, dx$. We write

$$\int \cos^3 ax \, dx = \int \left(\frac{3}{4} \cos ax + \frac{1}{4} \cos 3ax \right) dx = \frac{3}{4} \int \cos ax \, dx + \frac{1}{4} \int \cos 3ax$$

dx

$$= \frac{3}{4a} \sin ax + \frac{1}{12a} \sin 3ax + c$$

Example 12: Let us evaluate (i) $\int \sin 3x \cos 4x$ and (ii) $\int \sin x \sin 2x \sin 3x \, dx$

Here the integrand is the form of a product of trigonometric functions. We shall write it as a sum of trigonometric functions so that it can be integrated easily.

$$(i) \int \sin 3x \cos 4x \, dx = \int \frac{1}{2} (\sin 7x - \sin x) \, dx = \frac{1}{2} (\sin 7x \, dx - \frac{1}{2} \int \sin x$$

$$= -\frac{1}{14} \cos 7x + \frac{1}{2} \cos x + c$$

(ii) To evaluate $\int \sin 2x \cos 3x \, dx$, again we express the product $\sin x \sin 2x \sin 3x$ as a sum of trigonometric functions.

$$\sin x \sin 2x \sin 3x = \frac{1}{2} \sin x (\cos x - \cos 5x) = \frac{1}{2} \sin x \cos x \sin x \cos 5x$$

$$= \frac{1}{4} \sin 2x - \frac{1}{4} (\sin 6x - \sin 4x)$$

Therefore, $\int \sin x \sin 2x \sin 3x \, dx = \frac{1}{4} \int \sin 2x \, dx + \frac{1}{4} \int \sin 4x \, dx - \frac{1}{4} \int \sin 6x \, dx$

$$= -\frac{1}{8} \cos 2x - \frac{1}{16} \cos 4x + \frac{1}{24} \cos 6x + c$$

Check your progress

(4) Proceeding exactly as in Example 8, full up the blanks in the table below.

S.No.	f(x)	$\int f(x) \, dx$
1.	Sin ax	$-\frac{1}{a} \cos ax + c$
2.	cos ax	$\frac{1}{a} \sin ax + c$
3.	$\sec^2 ax$
4.	$\operatorname{cosec}^2 ax$
5.	Cosec ax cot ax
6.	$\sec^{ax} \tan x$
7.	e^{mx}
8.	a^{nx}

(5) Evaluate the following integrals

(a) $\int \sec x \, dx$ (b) $\int_0^{\pi/2} \sin^2 x \cos x \, dx$ (c) $\int e^{\tan x} \sec^2 x \, dx$

(6) Evaluate each of the following integrals.

(a) (i) $\int \sin^5 x \cos x \, dx$, (ii) $\int \frac{\cos x}{\sin^3 x} \, dx$ (iii) $\int_{\pi/6}^{\pi/3} \cot 2x \operatorname{cosec}^2 2x \, dx$

(iv) $\int \sin 2\theta e^{\cos 2\theta} \, d\theta$ (v) $\int_0^{\pi/2} \sin \theta (1 + \cos^4 \theta) \, d\theta$

(a) (i) $\int (1 + \cos \theta)^4 \sin \theta \, d\theta$ (ii) $\int_0^{\pi/3} \frac{\sin^2 \theta \, d\theta}{(1 - 5 \tan \theta)}$

$$(b) \text{ (iii) } \int_0^{\pi/4} \sec\theta \tan\theta (1+\sec\theta)^3 d\theta$$

$$(c) \text{ (i) } \int \sin^4\theta d\theta \qquad \text{(ii) } \int \sin 3\theta \cos\theta d\theta$$

$$\text{(iii) } \int_0^{\pi/2} \cos 5\theta \cos\theta d\theta \qquad \text{(iv) } \int_0^{\pi/2} \cos\theta \cos 2\theta \cos 4\theta d\theta$$

1.5.3 Trigonometric and Hyperbolic Substitution

Various trigonometric and hyperbolic identities like $\sin^2\theta + \cos^2\theta=1$

$1+ \tan^2\theta = \sec^2\theta$, $\tanh\theta = \frac{\sinh\theta}{\cosh\theta}$ and so on, prove very useful while evaluating certain integrals. In this section we shall see how.

A trigonometric or hyperbolic substitution is generally used to integrate expressions involving $\sqrt{a^2 - x^2}$, $\sqrt{x^2 - a^2}$ or $a^2 + x^2$. We suggest the following substitutions

Expression involved	Substitution
$\sqrt{a^2 - x^2}$	$x=a \sin\theta$
$\sqrt{a^2 + x^2}$	$x = a \tan\theta$ or $a \sinh \theta$
$\sqrt{x^2 - a^2}$	$x = a \sec\theta$ or $a \cosh\theta$
a^2+x^2	$x = a \tan \theta$

Thus to evaluate $\int \frac{dx}{\sqrt{a^2 - x^2}}$, put $x = a \sin\theta$. Then we know that $\frac{dx}{d\theta} = a \cos\theta$. This means we can write

$$\int \frac{dx}{\sqrt{a^2 - x^2}} = \int \frac{a \cos\theta d\theta}{\sqrt{a^2 - a^2 \sin^2\theta}} = \int \frac{a \cos\theta d\theta}{a \cos\theta} = \int d\theta = \theta + c = \sin^{-1}(x/a) + c$$

Similarly to evaluate $\int \frac{dx}{a^2 + x^2}$, we shall put $x = a \tan \theta$

$$\text{Since } \frac{dx}{d\theta} = \sec^2\theta d\theta, \text{ we get } \int \frac{dx}{a^2 + x^2} = \int \frac{a \sec^2\theta d\theta}{a^2 + a^2 \cdot \tan^2\theta}$$

$$= \int \frac{a \sec^2\theta d\theta}{a^2 \sec^2\theta} = \frac{1}{a} \int d\theta = \frac{\theta}{a} + c = \frac{1}{a} \tan^{-1}(x/a) + c$$

We can also evaluate $\int \frac{dx}{\sqrt{a^2 + x^2}}$, by substituting $x = a \tan \theta$. This gives

$$\frac{dx}{d\theta} = a \sec^2 \theta. \text{ Thus,}$$

$$\begin{aligned} \int \frac{dx}{\sqrt{a^2 + x^2}} &= \int \frac{a \sec^2 \theta d\theta}{\sqrt{a^2 + a^2 \tan^2 \theta}} = \int \sec \theta d\theta = \ln |\sec \theta + \tan \theta| + c \\ &= \ln \left| \frac{x + \sqrt{a^2 + x^2}}{a} \right| + c \end{aligned}$$

We can also evaluate this integral by putting $x = \sinh \theta$. With this substitution we get, $\int \frac{dx}{\sqrt{a^2 + x^2}} = \sinh^{-1}(x/a) + c$, and we know that

$$\begin{aligned} \sinh^{-1}(x/a) &= \ln \frac{x + \sqrt{x^2 + a^2}}{a} \quad \text{similarly,} \quad \int \frac{dx}{\sqrt{x^2 - a^2}} = \cosh^{-1}(x/a) + c, \\ &= \ln \frac{x + \sqrt{x^2 - a^2}}{a} + c \quad \text{and} \quad \int \frac{dx}{x\sqrt{x^2 - a^2}} = \frac{1}{a} \sec^{-1}(x/a) + c \end{aligned}$$

Let us put these results in the form of a table 3

Table 3		
S.No.	f(x)	$\int f(x) dx$
1.	$\frac{1}{\sqrt{a^2 - x^2}}$	$\sin^{-1}(x/a) + c$
2.	$\frac{1}{a^2 + x^2}$	$\frac{1}{a} \tan^{-1}(x/a) + c$
3.	$\frac{a}{x\sqrt{x^2 - a^2}}$	$\frac{1}{a} \sec^{-1}(x/a) + c$
4.	$\frac{1}{\sqrt{a^2 - x^2}}$	$\ln \left \frac{x + \sqrt{x^2 + a^2}}{a} \right + c$ Or $\sinh^{-1}(x/a) + c$
5.	$\frac{1}{\sqrt{x^2 - a^2}}$	$\ln \left \frac{x + \sqrt{x^2 - a^2}}{a} \right + c$ Or $\cosh^{-1}(x/a) + c$

Sometimes the integrand does not seem to fall in any of the types mentioned, but it is possible to modify or rearrange it so that it conforms to one of these types.

Example 13: Suppose we want to evaluate $\int_1^2 \frac{dx}{\sqrt{2x-x^2}}$

Let us try to rearrange the terms in the integrand $\frac{1}{\sqrt{2x-x^2}}$ to suit us. We

will see that $\int_1^2 \frac{dx}{\sqrt{2x-x^2}} = \int_1^2 \frac{dx}{\sqrt{1-(x-1)^2}}$

If we put $x-1=v$, $\frac{dv}{dx}=1$ and $\int_1^2 \frac{dx}{\sqrt{2x-x^2}} = \int_1^2 \frac{dv}{\sqrt{1-v^2}}$. Note that

new limits of integration. We get $\int_1^2 \frac{dx}{\sqrt{2x-x^2}} = \left. \sin^{-1} v \right|_0^1 = \sin^{-1} 1 -$

$$\sin^{-1} 0 = -\frac{\pi}{2}$$

Example 14: The integration in $\int \frac{x^2}{1+x^6} dx$

If we put $x^3=u$, $\frac{du}{dx}=3x^2$, thus $\int_0^1 \frac{x^2}{1+x^6} dx = \frac{1}{3} \int_0^1 \frac{3x^2}{1+x^6} dx$

$$= \frac{1}{3} \int_0^1 \frac{1}{1+u^2} du dx$$

$$= \frac{1}{3} \int_0^1 \frac{1}{1+u^2} du, \text{ by Theorem 3 } (\because u=1 \text{ when } x=1 \text{ and } u=0 \text{ when } x=0)$$

Here the integrand $\frac{1}{1+u^2}$ can be evaluated. Thus, we get

$$\frac{1}{3} \int_0^1 \frac{3x^3}{1+x^6} dx = \left. \frac{1}{3} \tan^{-1} u \right] = \frac{1}{3} \left(\frac{\pi}{4} - 0 \right) = \frac{\pi}{12}$$

1.6 Properties of Definite Integrals

We have already derived some properties of the definite integrals. These are the

- (i) **Constant Function Property:** $\int_a^b c dx = c(b-a)$

(ii) **Constant Multiple Property:** $\int_a^b kf(x)dx = k\int_a^b f(x)dx$

(iii) **Interval Union Property:** $\int_a^b f(x)dx = \int_a^c f(x)dx + \int_c^b f(x)dx$ where $a \leq c \leq b$.

(iv) **Comparison Property:** If $c \leq f(x) \leq d \forall x \in [a, b]$,
then $c(b - a) \leq \int_a^b f(x) dx \leq d(b - a)$

Now we shall use the method of substitution to derive two more properties to add to this list. Let's consider them one by one

(v) $\int_0^a f(x)dx = \int_0^{a/2} f(x)dx + \int_0^{a/2} f(a - x)dx$ for any integrable function f .

We already know that $\int_0^a f(x)dx = \int_0^{a/2} f(x) dx + \int_0^{a/2} f(a - x) dx$ for any integrable function f . We already know that $\int_0^a f(x)dx = \int_0^{a/2} f(x) dx + \int_{a/2}^a f(x)dx$

Now if we put $x = a - y$ in the second integral on the right hand side, then since $\frac{dy}{dx} = -1$, we get

$$\int_{a/2}^a f(x)dx = \int_{a/2}^0 f(a - y)dy = \int_0^{a/2} f(a - y)dy = \int_0^{a/2} f(a - x)dx$$

Since x is a dummy variable. Thus $\int_0^a f(x) dx = \int_0^{a/2} f(x) dx + \int_0^{a/2} f(a - x) dx$.

Example 15: Let us evaluate (i) $\int_0^\pi \sin^4 x \cos^5 x dx$ and (ii) $\int_0^{2\pi} \cos^3 x dx$

(i) Using property (v), we can write

$$\begin{aligned} \int_0^\pi \sin^2 x \cos^5 x dx &= \int_0^{\pi/2} \sin^4 x \cos^5 x dx + \int_0^{\pi/2} \sin^4 (\pi-x) \cos^5 (\pi - x) dx \\ &= \int_0^{\pi/2} \sin^4 x \cos^5 x dx + \int_0^{\pi/2} \sin^4 x (-\cos x)^5 dx \\ &= \int_0^{\pi/2} \sin^4 x \cos^5 x dx - \int_0^{\pi/2} \sin^4 x (\cos^5 x) dx = 0 \end{aligned}$$

(ii) $\int_0^{2\pi} \cos^3 x dx = \int_0^\pi \cos^3 (2\pi - x) dx = \int_0^\pi \cos^3 x dx + \int_0^\pi \cos^3 (2\pi - x) dx$
 $= 2 \int_0^\pi \cos^3 x dx = 2 \left[\int_0^{\pi/2} \cos^3 x dx + \int_0^{\pi/2} \cos^3 (\pi - x) dx \right]$

$$= 2 \left[\int_0^{\pi/2} \cos^3 x \, dx - \int_0^{\pi/2} \cos^3 x \, dx \right] = 0$$

Our next property greatly simplifies some integrals when the integrands are even or odd function.

(vi) If f is even function of x , i.e., $f(-x) = f(x)$, then $\int_a^b f(x) \, dx = 2 \int_0^a f(x) \, dx$

And if f is an odd function i.e. $f(-x) = -f(x)$, then $\int_a^a f(x) \, dx = 0$

We shall prove the result for even functions. The result for odd functions follows easily and is left to you as an exercise.

$$\text{Then } \int_{-a}^a f(x) \, dx = \int_{-a}^0 f(x) \, dx + \int_0^a f(x) \, dx$$

If we put $x = -y$ in the first integral on the right hand side, we get

$$\int_{-a}^0 f(x) \, dx = \int_a^0 f(-y) \, (-dy) = \int_a^0 f(y) \, dy = \int_0^a f(x) \, dx. \quad \text{Thus}$$

$$\int_{-a}^a f(x) \, dx = 2 \int_0^a f(x) \, dx$$

Using this property we can directly say that

$$\int_{-\pi/2}^{\pi/2} \sin x \, dx = 0 \int_{-\pi/2}^{\pi/2} \cos x \, dx = 2 \int_0^{\pi/2} \cos x \, dx = 2 \sin x \Big|_0^{\pi/2} = 2$$

Check your progress

- (7) The cost of a transistor radio is Rs. 700/-. Its value is depreciating with time according to the formula $\frac{dv}{dt} = \frac{-500}{(1+t^2)}$ where Rs. V is its value at t years after its purchase. What will be its value 3 years after its purchase? (Don't forget the constant of integration. Think how you can find it which the help of the given information).
- (8) Integrate each of the following with respect to the corresponding variable

(i) $\frac{1}{\sqrt{9-x^2}}$ (ii) $\frac{1}{\sqrt{u^2-4}}$ (iii) $\frac{1}{\sqrt{1+4x^2}}$

(iv) $\frac{1}{\sqrt{2x^2+5}}$

$$(v) \frac{x}{\sqrt{x^4 - 1}} \quad (vi) \frac{t^2}{\sqrt{t^6 + 16}} \quad (vii) \frac{u^2}{\sqrt{4 - u^6}}$$

$$(viii) \frac{1}{\sqrt{2x - x^3}}$$

$$(ix) \frac{1}{\sqrt{1 + x + x^2}} \quad (x) \frac{1}{y^2 + 6y + 5}$$

$$(xi) \frac{x^2}{1 + x^2} \text{ (hint: } \frac{x^2}{1 + x^2} = 1 - \frac{1}{1 + x^2} \text{)}$$

$$(9) \quad (a) \text{ Evaluate } \int_0^\pi \sin^5 x \cos^3 x \, dx$$

$$(b) \text{ Show that } \int_0^{\pi/2} \sin 2x \ln(\tan x) \, dx = 0$$

$$(c) \text{ Prove that } \int_{-a}^a f(x) \, dx = 0 \text{ if } f \text{ is an odd function of } x.$$

In this section we have seen how the method of substitutions enables us to substantially increase our list of integrable functions. (Here by “integrable function” we mean a function which we can integrate)

1.7 Integration By Parts

In this section we shall evolve a method for evaluating integrals of the types

$\int u(x)v(x) \, dx$, in which the integrand $u(x)v(x)$ is the product of two functions. In other words, we shall first evolve the integral analogue of

$$\frac{d}{dx}[u(x)v(x)] = u(x) \frac{d}{dx} v(x) + v(x) \frac{d}{dx} u(x)$$

and then use that result to evaluate some standard integrals.

Integrals of a Product of Two Functions

We can calculate the derivative of the product of two functions by the formula

$$\frac{d}{dx}[u(x)v(x)] = u(x) \frac{d}{dx} v(x) + v(x) \frac{d}{dx} u(x)$$

$$\text{Let us rewrite this as } u(x) \frac{d}{dx} v(x) \, dx = \int \frac{d}{dx}[u(x)v(x)] - v(x) \frac{d}{dx} u(x)$$

Integrating both the sides with respect to x , we have

$$\int u(x) \frac{d}{dx} (v(x)) dx = \int \frac{d}{dx} (u(x)v(x)) dx - \int v(x) \frac{d}{dx} (u(x)) dx. \text{ Or}$$

$$\int u(x) \frac{d}{dx} (v(x)) dx = u(x) v(x) - \int v(x) \frac{d}{dx} (u(x)) dx \quad \dots\dots(1)$$

To express this in a more symmetrical form, we replace $u(x)$ by $f(x)$, and put

$$\frac{d}{dx} v(x) = g(x). \text{ This means } v(x) = \int g(x) dx.$$

As a result of this substitution, (1) takes the form

$$\int f(x)g(x) dx = f(x) \int g(x) dx - \int \{f'(x) \int g(x) dx\} dx$$

This formula may be read as:

The integral of the product of two functions = First factor \times integral of second factor – integral of (derivative of first factor \times integral of second factor)

It is called the formula for integration by parts. This formula may appear a little complicated to you. But the success of this method depends upon choosing the first factor in such a way that the second term on the right hand side may be easy to evaluate. It is also essential to choose the second factor such that it can be easily integrated.

Example 16: Let us use the method of integration by parts to evaluate $\int xe^x dx$.

In the integrand xe^x we chose x as the first factor and e^x as the second factor. Thus, we get

$$\int xe^x dx = x \int e^x dx - \int \frac{d}{dx} (x) \int e^x dx \} dx = xe^x - \int e^x dx$$

Example 17: To evaluate $\int_0^{\pi/2} x^2 \cos x dx$. We shall take x^2 as the first factor and $\cos x$ as the second. Let us first evaluate the corresponding indefinite integral.

$$\begin{aligned} \int x^2 \cos x dx &= x^2 \int \cos x dx - \int \left\{ \frac{d}{dx} (x^2) \cos x dx \right\} dx = x^2 \sin x - \int 2x \sin x dx \\ &= x^2 \sin x - 2 \int x \sin x dx \end{aligned}$$

We shall again use the formula of integration by parts to evaluate $\int x \sin x dx$. Thus $\int x \sin x dx = x (-\cos x) - \int (1) (-\cos x) dx$ as $(f(x) = x, g(x) = \sin(x))$

$$= -x \cos x + \int \cos x dx = -x \cos x + \sin x + c$$

$$\text{Hence, } \int x^2 \cos x \, dx = x^2 \sin x + 2x \cos x - 2 \sin x + c$$

Note that we have written the arbitrary constant as c instead of $2c$

$$\text{Now } \int_0^{\pi/2} x^2 \cos x \, dx = (x^2 \sin x + 2x \cos x - 2 \sin x + c) \Big|_0^{\pi/2}$$

Example 18: Let us now evaluate $\int x \ln |x| \, dx$

Here we take $\ln |x|$ as the first factor since it can be differentiated easily, but cannot be integrated that easily. We shall take x to be the second factor.

$$\begin{aligned} \int x \ln |x| \, dx &= \int \ln |x| \cdot x \, dx = (\ln |x|) \frac{x^2}{2} - \int \left(\frac{1}{x} \right) \left(\frac{x^2}{2} \right) dx \\ &= \frac{1}{2} x^2 \ln |x| - \frac{1}{2} \int x \, dx = \frac{1}{2} x^2 \ln |x| - \frac{1}{4} x^2 - c \end{aligned}$$

While choosing $\ln |x|$ as the first factor, we mentioned that it cannot be integrated easily. The method of integration by parts, in fact, helps us in integrating $\ln x$ too.

Example 19: We can find $\int \ln x \, dx$ by taking $\ln x$ as the first factor and 1 as the second factor. Thus, $\int \ln x \, dx = \int (\ln x) (1) \, dx$

$$= \ln x \int 1 \, dx - \int \left(\frac{1}{x} \int 1 \, dx \right) dx = (\ln x) (x) - \int \frac{1}{x} (x) \, dx$$

$$= x \ln x - \int dx = x \ln x - x + c = x \ln x - x \ln e + c \text{ since } \ln e = 1 = x \ln (x/e) + c$$

1.7.1 Evaluations of $\int e^{ax} \sin bx \, dx$ and $\int e^{ax} \cos bx \, dx$

To evaluate $\int e^{ax} \sin bx \, dx$ and $\int e^{ax} \cos bx \, dx$, we use the formula for

integration by parts. $\int e^{ax} \sin bx \, dx = (e^{ax}) \left(-\frac{1}{b} \cos bx\right) - (ae^{ax}) \left(-\frac{1}{b} \cos bx\right)$

$$dx = -\frac{1}{b} e^{ax} \cos bx + \frac{a}{b} \int e^{ax} \cos bx \, dx = -\frac{1}{b} e^{ax} \cos bx + \frac{a}{b^2} e^{ax} \sin bx -$$

$$\frac{a}{b^2} \int \sin bx \, dx$$

$$\text{We obtain. } \left(1 + \frac{a^2}{b^2}\right) \int e^{ax} \sin bx \, dx = e^{ax} \left(\frac{a}{b^2} \sin bx - \frac{1}{b} \cos bx\right)$$

$$\text{This means, } \int e^{ax} \sin bx \, dx = \frac{1}{a^2 + b^2} e^{ax} (a \sin bx - b \cos bx) + c$$

We can similarly show that $\int e^{ax} \cos bx \, dx = \frac{1}{a^2 + b^2} e^{ax} (a \cos bx - b \sin bx) + c$

If we put $a = r \cos \theta$, $b = r \sin \theta$, these formulas become

$$\int e^{ax} \sin bx \, dx = \frac{1}{\sqrt{a^2 + b^2}} e^{ax} \sin (bx - \theta) + c$$

$$\int e^{ax} \cos bx \, dx = \frac{1}{\sqrt{a^2 + b^2}} e^{ax} \cos (bx - \theta) + c, \text{ where } \theta = \tan^{-1} \frac{b}{a}.$$

Example 20: using the formula discussed in this sub-section, we can easily check that

$$(i) \int e^x \sin x \, dx = \frac{1}{\sqrt{2}} e^x \sin (x - \frac{\pi}{4}) + c. \text{ and}$$

$$(ii) \int e^x \cos \sqrt{3x} \, dx = \frac{1}{2} e^x \cos (\sqrt{3x} - \frac{\pi}{3}) + c$$

Example 21: To evaluate $\int e^{2x} \sin x \cos 2x \, dx$, we shall first write

$$\sin x \cos 2x = \frac{1}{2} (\sin 3x - \sin x). \text{ Therefore, } \int e^{2x} \sin x \cos 2x \, dx$$

$$= \frac{1}{2} \int e^{2x} \sin 3x \, dx - \frac{1}{2} \int e^{2x} \sin x \, dx$$

Now the two integrals on the right hand side can be evaluated. We see that

$$\int e^{2x} \sin 3x \, dx = \frac{1}{\sqrt{13}} e^{2x} \sin (3x + \tan^{-1} \frac{3}{2}) + c \text{ and}$$

$$\int e^{2x} \sin x \, dx = \frac{1}{\sqrt{5}} e^{2x} \sin (x - \tan^{-1} \frac{1}{2}) + c. \text{ Hence}$$

$$\int e^{2x} \sin x \cos 2x \, dx = e^{2x} \left[\frac{1}{\sqrt{13}} \sin (3x - \tan^{-1} \frac{3}{2}) - \frac{1}{\sqrt{5}} \sin (x - \tan^{-1} \frac{1}{2}) \right] + c$$

Example 22: Suppose we want to evaluate $\int x^3 \sin (a \ln x) \, dx$

Let $\ln x = u$, This implies $x = e^u$ and $du/dx = 1/x$

Then, $\int x^3 \sin (a \ln x) \, dx = \int x^4 \sin (a \ln x) (1/x) \, dx$

$$= \int e^{4u} \sin au \, du = \frac{1}{\sqrt{16+a^2}} e^{4u} \sin(au) - \tan^{-1}(a/4) + c$$

$$= \frac{1}{\sqrt{16+a^2}} x^4 \sin(\ln x) - \tan^{-1} \frac{a}{4} + c$$

Check your progress

(10) Evaluate

(a) $\int x^2 \ln x \, dx$ Take $f(x) = \ln x$ and $g(x) = x^2$

(b) $\int (1+x) e^x \, dx$ Take $f(x) = 1+x$ and $g(x) = e^x$

(c) $\int (1+x^2) e^x \, dx$

(d) $\int x^2 \sin x \cos x \, dx$ Tak $f(x) = x^2$ and $g(x) =$

$$\sin x \cos x = \frac{1}{2} \sin 2x$$

(11) Evaluate the following integrals by choosing 1 as the second factor.

(a) $\int \sin^{-1} x \, dx$ (b) $\int_0^1 \tan^{-1} x \, dx$ (iii) $\int \cot^{-1} x \, dx$

(12) Integrate: (a) $x \sin^{-1} x$ (b) $\ln(1+x^2)$ w.r.t.x.

(13) Evaluate the following integrals

(a) $\int a^{2x} \cos 4x \, dx$ (b) $\int e^{3x} \sin 3x \, dx$ (c) $\int e^{4x} \cos x \cos 2x \, dx$
 (d) $\int e^{2x} \cos^2 x \, dx$

(e) $\int \cos h ax \sin bx \, dx$ (write $\cosh ax$ in terms of the exponential function)

(f) $\int x e^{ax} \sin bx \, dx$

1.7.2 Evaluation of $\int \sqrt{a^2 - x^2} \, dx$, $\int \sqrt{a^2 + x^2} \, dx$, and $\int \sqrt{x^2 - a^2} \, dx$

In this sub-section, we shall see that integrals like $\int \sqrt{a^2 - x^2} \, dx$, $\int \sqrt{a^2 + x^2} \, dx$ and $\int \sqrt{x^2 - a^2} \, dx$ can also be evaluated with the help of the formula for integration by parts and table 3.

$$\int \sqrt{a^2 - x^2} \, dx = \int \sqrt{a^2 + x^2} \, dx \tag{1}$$

$$= \sqrt{a^2 - x^2} \times x - \int \left(\frac{-x}{\sqrt{a^2 - x^2}} \times x \right) dx$$

$$\begin{aligned}
&= x\sqrt{a^2 - x^2} + \int \frac{x^2}{\sqrt{a^2 - x^2}} dx = x\sqrt{a^2 - x^2} - \int \frac{(a^2 - x^2)}{\sqrt{a^2 - x^2}} dx \\
&= x\sqrt{a^2 - x^2} + a^2 \int \frac{dx}{\sqrt{a^2 - x^2}} - \int \sqrt{a^2 - x^2} dx
\end{aligned}$$

Shifting the last term on the right hand side to the left we get

$$2 \int \sqrt{a^2 - x^2} dx = x\sqrt{a^2 - x^2} + a^2 \int \frac{dx}{\sqrt{a^2 - x^2}}$$

Using the formula $\int \frac{dx}{\sqrt{a^2 - x^2}} = \sin^{-1}\left(\frac{x}{a}\right) + c$, we obtain

$$\int \sqrt{a^2 - x^2} dx = \frac{1}{2} x\sqrt{a^2 - x^2} + \frac{a^2}{2} \sin^{-1}\left(\frac{x}{a}\right) + c$$

Similarly, we shall have

$$\int \sqrt{a^2 + x^2} dx = \frac{1}{2} x\sqrt{a^2 + x^2} + \frac{a^2}{2} \sin^{-1}\left(\frac{x}{a}\right) + c$$

$$= \frac{1}{2} x\sqrt{a^2 + x^2} + \frac{a^2}{2} \ln \frac{x + \sqrt{a^2 + x^2}}{a} + c \text{ and}$$

$$\int \sqrt{x^2 - a^2} dx = \frac{1}{2} x\sqrt{x^2 - a^2} - \frac{a^2}{2} \cosh^{-1}\left(\frac{x}{a}\right) + c$$

$$= \frac{1}{2} x\sqrt{x^2 - a^2} - \frac{a^2}{2} \ln \frac{x + \sqrt{x^2 - a^2}}{a} + c$$

Example 23: Let us evaluate $\int_0^1 \sqrt{x + x^2} dx$

Now $\int_0^1 \sqrt{x + x^2} dx = \int_0^1 \sqrt{(x + 1/2)^2 - 1/4} dx$ Let $x + \frac{1}{2} = u$,

$$\begin{aligned}
\int_0^1 \sqrt{x + x^2} dx &= \int_{1/2}^{3/2} \sqrt{u^2 - 1/4} du \\
&= \left\{ \frac{1}{2} u\sqrt{u^2 - 1/4} - \frac{1}{8} \ln \frac{u + \sqrt{u^2 - 1/4}}{1/2} \right\}_{1/2}^{3/2}
\end{aligned}$$

$$= \frac{3\sqrt{2}}{4} = \frac{1}{8} \ln(3 + 2\sqrt{2})$$

1.7.3 Integrals of the Type $\int e^x [f(x) + f'(x)] dx$

We first prove that formula $\int e^x [f(x)+f'(x)]dx = e^x f(x) + c$ and see how it can be used in integrating some functions.

By the formula for integration by parts $\int e^x f(x) dx = \int f(x)e^x dx$

$= f(x) e^x - \int f'(x) e^x dx + c$. This implies $\int e^x [f(x) + f'(x)] dx = e^x f(x) + c$

Example 24 Let us evaluate the following integrals.

$$(i) \int \frac{1+x}{(2+x)^2} e^x dx \quad (ii) \int \frac{\sqrt{1-\sin x}}{1+\cos x} e^{-x/2} dx$$

We take up (i) first,

$$\begin{aligned} \int \frac{1+x}{(2+x)^2} e^x dx &= \int \frac{(2+x)-1}{(2+x)^2} e^x dx = \int \left[\frac{1}{2+x} + \frac{-1}{(2+x)^2} \right] e^x dx \\ &= \frac{1}{2+x} e^x + c, \text{ since } \frac{-1}{(2+x)^2} = \frac{d}{dx} \left(\frac{1}{2+x} \right) \end{aligned}$$

Now we shall evaluate (ii)

$$(a) \int \frac{\sqrt{1-\sin x}}{1+\cos x} e^{-x/2} dx = \int \frac{\cos \frac{x}{2} - \sin \frac{x}{2}}{2 \cos^2 x} e^{-x/2} dx$$

$$= \frac{1}{2} \int \sec \frac{x}{2} e^{-x/2} dx - \frac{1}{2} \int \tan \frac{x}{2} \sec \frac{x}{2} e^{-x/2} dx. \text{ Now}$$

$$\int \sec \frac{x}{2} e^{-x/2} dx = \left(\sec \frac{x}{2} \right) (-2e^{-x/2}) - \int \left(\frac{1}{2} \sec \frac{x}{2} \right) (-2e^{-x/2}) dx$$

$$= -2 \sec \frac{x}{2} e^{-x/2} + \int \sec \frac{x}{2} \tan \frac{x}{2} e^{-x/2} dx. \text{ Thus,}$$

$$\int \frac{\sqrt{1-\sin x}}{1+\cos x} e^{-x/2} dx$$

$$= -\sec \frac{x}{2} e^{-x/2} + \frac{1}{2} \int \sec \frac{x}{2} dx - \frac{1}{2} \int \sec \frac{x}{2} \tan \frac{x}{2} e^{-x/2} dx$$

$$= -\sec \frac{x}{2} e^{-x/2} + c$$

Check your progress

(14) Verify that

$$(a) \int \sqrt{a^2 + x^2} dx = \frac{1}{2} x \sqrt{a^2 + x^2} + \frac{a^2}{2} \ln \frac{x + \sqrt{a^2 + x^2}}{a} + c$$

$$(b) \int \sqrt{x^2 - a^2} dx = \frac{1}{2} x \sqrt{x^2 - a^2} - \frac{a^2}{2} \ln \frac{x + \sqrt{x^2 - a^2}}{a} + c$$

(15) Evaluate the following integrals

$$(a) \int (2x^3 + 2x + 3) dx \quad (b) \int \frac{x^2 + 2}{x} dx,$$

$$(c) \int \sinh(x/2) \cosh(x/2) dx$$

$$(d) \int (e^x - e^{-x})^2 dx \quad (e) \int_2^4 \frac{x^2}{\sqrt{x^3 + 1}} dx$$

$$(f) \int \frac{x}{(x^2 + 2)^8} dx \quad (g) \int \sin x e^{\cos x} dx$$

$$(h) \int \frac{1}{1 + 9x^2} dx \quad (i) \int_0^{\pi/2} \frac{\sin x \cos x}{(1 + \sin x)^3} dx$$

$$(j) \int (x^2 + x)^6 x^3 dx \quad (k) \int x \sqrt{x^4 + 2x^2 + 2} dx$$

$$(l) \int \frac{x \tan^{-1} x}{(1 + x^2)^{3/2}} dx \quad (m) \int \cos^{-1} \left(\frac{1 - x^2}{1 + x^2} \right) dx$$

(16) Prove that $\int u \frac{d^2v}{dx^2} dx = u \frac{dv}{dx} - v \int \frac{d^2u}{dx^2} dx$, and use it to

evaluate $\int x^3 \sin x dx$

Note:

The results, $\int_a^b f(x) dx = [F(x)]_a^b = F(b) - F(a)$

Where $F(x)$ is the antiderivatives of $f(x)$, $F(x)$ will make sense only if $f(x)$ exists at every point of the interval. Hence we have to be careful in using this result.

$$\text{Thus, } \int \frac{1}{x} dx = [\ln |x|]_a^b = \ln \frac{|b|}{|a|}$$

But $1/x$ is not defined at $x = 0$, and $\ln |x|$ is also not differentiable at $x = 0$. As such, at this stage, we should use the result only if the interval $[a, b]$ does not include $x = 0$.

$$\text{Thus, } \int_{-1}^2 \frac{1}{x} dx = \ln \frac{|2|}{|-1|} = \ln 2 \text{ is not valid. } \int_{-2}^1 \frac{1}{x} dx = \ln \frac{|-1|}{|-2|} = \ln \frac{1}{2} \text{ is valid}$$

$$\text{Again, consider } \int_0^1 \frac{1}{\sqrt{1-x^2}} dx = [\sin^{-1}x]_0^1 = \frac{\pi}{2}$$

However $\frac{1}{\sqrt{1-x^2}}$ does not exist at $x = 1$, and $\sin^{-1}x$ is not differentiable at $x = 1$. $L(\sin^{-1}x)$ exists at $x = 1$, but $R(\sin^{-1}x)$ does not exist, since $\sin^{-1}x$ itself does not exist when $x > 1$.

The antiderivative of every function need not exist, i.e. it need not be any of the functions we are familiar with. For example, there is no function known to us whose derivative is e^{-x^2} . However the value of the definite integral $\int_a^b f(x) dx$ of every function, where $f(x)$ is continuous on the interval $[a, b]$, can be found out by numerical methods to any degree of approximation. We can find the approximate value of $\int_a^b e^{-x^2} dx$, for all real values of a and b . In fact, this integral is very important in probability theory and you will use it very often if you take the course on probability and statistics.

1.8 Summary

In this unit we have covered the following points

- (1) If $F(x)$ is an antiderivative of $f(x)$, then the indefinite integral (or simply, integral) of $f(x)$ is

$$\int f(x) dx = F(x) + c, \text{ where } c \text{ is an arbitrary constant}$$

- (2) $\int [k_1 f_1(x) + k_2 f_2(x) + \dots + k_n f_n(x)] dx =$

$$k_1 \int f_1(x) dx + k_2 \int f_2(x) dx + \dots + k_n \int f_n(x) dx$$

(3) The method of substitutions gives “

$$\int_a^b f[g(x)]g'(x)dx = \int_{g(a)}^{g(b)} f(u) du, \text{ if } u = g(x)$$

In particular

$$\int [f(x)]^n f'(x) dx = \frac{[f(x)]^{n+1}}{n+1} + c, n \neq -1, \text{ and } \int \frac{f'(x)}{f(x)} dx = \ln |f(x)| + c$$

$$\int_0^a f(x) dx = \int_0^{a/2} f(x) dx + \int_0^{a/2} f(a-x) dx$$

$$\int_a^a f(x) dx = \begin{cases} 2 \int_0^a f(x) dx, \text{ if } f \text{ is even} \\ 0, \text{ if } f \text{ is odd} \end{cases}$$

(4) Standard formulas

$$\int \frac{dx}{\sqrt{a^2 - x^2}} = \sin^{-1} \frac{x}{a} + c$$

$$\int \frac{dx}{\sqrt{a^2 + x^2}} = \ln \frac{x + \sqrt{a^2 + x^2}}{a} + c$$

$$\int \frac{dx}{\sqrt{x^2 - a^2}} = \ln \frac{x + \sqrt{x^2 - a^2}}{a} + c$$

(5) Integration of a product of two functions (integration by parts),

$$(x)v(x)dx = u(x) \int v(x)dx - \int \{u'(x)\} \int v(x)dx \} dx$$

$$\text{This leads us to: } \int \sqrt{a^2 - x^2} dx = \frac{1}{2} \sqrt{a^2 - x^2} + \frac{a^2}{2} \sin^{-1} \frac{x}{a} + c$$

$$\int \sqrt{a^2 - x^2} dx = \frac{1}{2} x \sqrt{a^2 - x^2} + \frac{a^2}{2} \ln \frac{x + \sqrt{a^2 + x^2}}{a} + c$$

$$\int \sqrt{x^2 - a^2} dx = \frac{1}{2} x \sqrt{x^2 - a^2} - \frac{a^2}{2} \ln \frac{x + \sqrt{x^2 + a^2}}{a} + c$$

$$\int e^{ax} \sin bx dx = \frac{1}{\sqrt{a^2 + b^2}} e^{ax} \sin (bx - \tan^{-1} \frac{b}{a}) + c$$

$$\int e^{ax} \cos bx dx = \frac{1}{\sqrt{a^2 + b^2}} e^{ax} \cos (bx - \tan^{-1} \frac{b}{a}) + c$$

$$\int e^x [f(x) + f'(x)] dx = e^x f(x) + c$$

Solution and answers of check your progress

(1) (a) (i) $\frac{x^5}{5} + c$ (ii) $-2x^{-1/2}$ (iii) $-4x^{-1} + c$ (iv) $3x + c$

(b) (i) $x - x^2 + \frac{x^3}{3} + c$ (ii) $\frac{x^3}{3} - 2x - \frac{1}{x} + c$

(iii) $x + \frac{3x^2}{1} + x^3 + \frac{x^4}{4} + c$

(c) (i) $e^x - e^{-x} + 4x + c$ (ii) $4\sin x + 3 \cos x + e^x + \frac{x^2}{2} + c$

(iii) $4\tanh x + e^k - 4x^2 + c$

(d) (i) $2\sin^{-1} x + 5\ln|x| + c$

(ii) $\int \frac{2(x^2 + 1) + 3}{x^2 + 1} dx = 2 \int dx + 3 \int \frac{1}{x^2 + 1} dx$

$= 2x + 3\tan^{-1} x + c$

(e) (i) $\frac{ax^4}{4} + \frac{bx^3}{3} + \frac{cx^2}{2} + dx + c$ (ii) $\frac{x^2}{2} - 2x + \ln|x| + c$

(f) (i) $\int \frac{\sin^4 x + \cos^4 x}{\sin^2 x \cos^2 x} dx =$

$\int \frac{(\sin^2 x + \cos^2 x)^2 - 2\sin^2 x \cos^2 x}{\sin^2 x \cos^2 x}$

$= \int \frac{1}{\sin^2 x} dx + \int \frac{1}{\cos^2 x} dx - 2 \int dx = -\cot x + \tan x - 2x + c$

(iii) $6x + \frac{3x^2}{2} - \frac{4}{3}x^{3/2} - \frac{2}{3}x^{5/2} + c$

(2) (a) (i) $\frac{6^5}{5} - 5^4$ (ii) $\frac{1}{2} + \ln 2$ (b) (i) $\frac{275}{12}$ (ii) $\frac{14}{5}$

(3) (a) $\int (5x - 3)^{1/2} dx = \frac{1}{5} \int 5(5x - 3)^{1/2} dx$ if $5x - 3 = u$, $\frac{du}{dx} = 5$

$= \frac{1}{5} \int u^{1/2} du = \frac{1}{5} \frac{u^{3/2}}{3/2} + c = \frac{2}{15} (5x - 3)^{3/2} + c$

$$(b) \frac{1}{14}(2x+1)^7 + c \quad (c) \frac{1}{5} \ln \frac{19}{9} \quad (d) \frac{1}{2} \ln |10x + 7| + c$$

$$(e) \frac{1}{2} \ln |x^2 + 2x + 7| + c$$

$$(f) \ln |x^3 + x^2 + x - 8| \Big|_2^3 = \ln \frac{31}{6}$$

$$(g) \frac{(3/4)(x^{4/3} - 1)^{3/2}}{3/2} + c = \frac{1}{2}(x^{4/3} - 1)^{3/2} + c$$

$$(h) -\frac{1}{3} \sqrt{1 - 3x^2} + c$$

(4)

S.No.	f(x)	$\int f(x) dx$
1.	$\sin ax$	$-\frac{1}{a} \cos ax + c$
2.	$\cos ax$	$\frac{1}{a} \sin ax + c$
3.	$\sec^2 ax$	$\frac{1}{a} \tan ax + c$
4.	$\operatorname{cosec}^2 ax$	$-\frac{1}{a} \cot ax + c$
5.	$\sec ax \tan ax$	$\frac{1}{a} \sec ax + c$
6.	$\operatorname{cosec} ax \cot ax$	$-\frac{1}{a} \operatorname{cosec} ax + c$
7.	e^{ax}	$\frac{1}{a} e^{ax} + c$
8.	a^{mx}	$\frac{1}{m \ln a} a^{mx} + c$

$$(5) \text{ (a) } \int \sec x dx = \int \frac{\sec x (\sec x + \tan x)}{\sec x + \tan x} dx = \ln |\sec x + \tan x| + c$$

$$(b) \int_0^{\pi/2} \sin^2 x \cos x dx = \frac{\sin^3 x}{3} \Big|_0^{\pi/2} = \frac{1}{3}$$

$$(c) \text{ if } u = \tan x, \frac{du}{dx} = \sec^2 x \Rightarrow \int e^{\tan x} \sec^2 x \, dx = \int e^u \, du = e^u = e^{\tan x} + c$$

$$(6) \quad (a) \quad (i) \quad \frac{\sin^6 x}{6} + c \qquad (ii) \quad \frac{-2}{\sin^2 x} + c$$

$$(iii) \quad \int_{\pi/6}^{\pi/3} \cot 2x \operatorname{cosec}^2 2x \, dx = \frac{1}{2} \int_{\pi/6}^{\pi/3} \cot 2x (2 \operatorname{cosec}^2 2x) \, dx$$

$$= \frac{1}{2} \times \left[\frac{\cot^2 2x}{2} \right]_{\pi/6}^{\pi/3} = 0$$

$$(iv) \text{ Put } \cos 2\theta = u, \text{ then } \frac{du}{d\theta} = -2 \sin 2\theta$$

$$\int \sin 2\theta e^{\cos 2\theta} d\theta = -\frac{1}{2} e^u du = -\frac{1}{2} e^u + c = -\frac{1}{2} e^{\cos 2\theta} + c$$

$$(v) \quad \int_0^{\pi/2} \sin \theta (1 + \cos^4 \theta) \, d\theta = \int_0^{\pi/2} \sin \theta \, d\theta + \int_0^{\pi/2} \sin \theta \cos^4 \theta \, d\theta$$

$$= -\cos \theta \Big|_0^{\pi/2} - \frac{\cos^5 \theta}{5} \Big|_0^{\pi/2} = 1 + \frac{1}{5} = \frac{6}{5}$$

$$(b) \quad (i) \quad -\frac{(1 + \cos \theta)^5}{5} + c$$

$$(ii) \quad \frac{1}{10} \frac{1}{(1 - 5 \tan \theta)^2} \Big|_0^{\pi/3} = \frac{1}{2} \frac{2\sqrt{3} - 15}{(1 - 5\sqrt{3})^2}$$

$$(iii) \quad \frac{(1 + \sec \theta)^4}{4} \Big|_0^{\pi/4} = \frac{(1 + \sqrt{2})^4 - 2^4}{4} = \frac{1 + 12\sqrt{2}}{4}$$

$$(c) \quad (i) \quad \int \sin^4 \theta = \int \sin^3 \theta \sin \theta \, d\theta = \int \left(\frac{3}{4} \sin^2 \theta - \frac{1}{4} \sin \theta \sin 3\theta \right) d\theta$$

$$= \frac{3}{8} \int \{1 - (1 - 2 \sin^2 \theta)\} d\theta - \frac{1}{8} \int (\cos 2 - \cos 4\theta)$$

$$= \frac{3}{8} \int d\theta - \frac{3}{8} \int \cos 2\theta d\theta - \frac{1}{8} \int \cos 2\theta d\theta + \frac{1}{8} \int \cos 4\theta d\theta$$

$$= \frac{3}{8}\theta - \frac{1}{2} \frac{\sin 2\theta}{2} + \frac{1}{8} \frac{\sin 4\theta}{4} + c$$

$$= \frac{1}{4} \left(\frac{3}{2}\theta - \sin 2\theta + \frac{1}{8}\sin 4\theta \right) + c$$

$$(ii) \int \sin 3\theta \cos \theta \, d\theta = \frac{1}{2} \left[\int \sin 4\theta \, d\theta + \int \sin 2\theta \, d\theta \right]$$

$$= \frac{1}{4} \left[-\frac{\cos 4\theta}{2} - \cos 2\theta + c \right]$$

$$(iii) \int_0^{\pi/2} \cos 5\theta \cos \theta \, d\theta = \frac{\sin 4\theta}{8} - \frac{\sin 6\theta}{12} \Big|_0^{\pi/2} = 0$$

$$(iv) \int_0^{\pi/2} \cos \theta \cos 2\theta \cos 4\theta \, d\theta = \frac{19}{105}$$

$$\int \frac{dx}{\sqrt{1+x+x^2}} = \int \frac{dx}{\sqrt{(3/4 + (x+1/2)^2)}} = \sin^{-1} \frac{x + (1/2)}{\sqrt{3/2}} + c$$

$$\ln \left| \frac{(x+1/2) + \sqrt{3/4 + (x+1/2)^2}}{\sqrt{3/2}} \right| + c$$

or

$$= \ln \left| \frac{(x+1/2) + \sqrt{x^2 + x + 1}}{\sqrt{3/2}} \right| + c$$

$$= \ln \left| \frac{2x + 1 + 2\sqrt{x^2 + x + 1}}{\sqrt{3}} \right|$$

$$(iii) \int \frac{dy}{\sqrt{y^2 + 6y + 5}} = \int \frac{dy}{\sqrt{(y+3)^2}} = \cosh^{-1} \left(\frac{y+3}{2} \right) + c$$

$$(iv) \int \frac{x^2}{1+x^2} dx = \int dx \int \frac{1}{1+x^2} dx = x - \tan^{-1} x + c$$

$$(7) \quad v = \int \frac{-500}{1+t^2} dt + c = -500 \tan^{-1} t + c, \quad v(0) = 700$$

$$= -5000 \tan^{-1} 0 + c = c \Rightarrow c = 700, \quad v(3) = 700 - 500 \tan^{-1} 3$$

$$(9) \quad (a) \int_0^{\pi} \sin^5 x \cos^3 x \, dx = \int_0^{\pi/2} \sin^5 x \cos^3 x \, dx + \int_0^{\pi/2} \sin^5 (\pi-x) \cos^2(\pi-x) \, dx$$

$$= \int_0^{\pi/2} \sin^5 x \cos^3 x \, dx - \int_0^{\pi/2} \sin^5 x \cos^3 x \, dx = 0$$

$$(b) \int_0^{\pi/2} \sin 2x \ln \tan x \, dx = \int_0^{\pi/4} \sin 2x \ln \tan x \, dx$$

$$= \int_0^{\pi/4} \sin 2x \frac{\pi}{2} (-x) \ln \tan \left(\frac{\pi}{2} - x \right) \, dx$$

$$= \int_0^{\pi/4} \sin 2x \ln \tan x \, dx + \int_0^{\pi/4} \sin 2x \ln \cot x \, dx$$

$$= \int_0^{\pi/4} \sin 2x \ln (\tan x \cot x) \, dx = \int_0^{\pi/4} \sin 2x \ln 1 \, dx = 0$$

$$(c) \int_{-a}^a f(x) \, dx = \int_{-a}^0 f(x) \, dx + \int_0^a f(x) \, dx$$

$$\text{Put } x = -y \quad \text{in } \int_{-a}^0 f(x) \, dx$$

$$= \int_0^a f(x) \, dx = - \int_0^a f(x) \, dx + \int_0^a f(x) \, dx = 0$$

$$(10) \quad (a) \int x^2 \ln x \, dx = \ln x \int x^2 \, dx - \int \left(\frac{1}{x} \int x^2 \, dx \right) \, dx$$

$$= \ln x \frac{x^3}{3} - \frac{1}{3} \int x^2 \, dx = \frac{x^3}{3} \ln x - \frac{x^3}{9} + c$$

$$(b) x e^{x+c}$$

$$(c) \int (1+x^2)e^x \, dx = (1+x^2)e^x - 2 \int x e^x \, dx = (1+x^2)e^x - 2[xe^x - \int e^x \, dx]$$

$$= (1+x^2)e^x - 2xe^x + 2e^x + c = e^x(x^2 - 2x + 3) + c$$

$$(d) \frac{1}{4} [-x^2 \cos^2 2x + x \sin 2x + \frac{1}{2} \cos 2x] + c$$

$$(11) \quad (a) \int 1 \cdot \sin^{-1} x \, dx = \sin^{-1} x \cdot x - \int \frac{1}{\sqrt{1-x^2}} x \, dx = x \sin^{-1} x + \sqrt{1-x^2} + c$$

$$(b) \frac{\pi}{4} - \frac{1}{2} \ln 2 \quad (c) x \cot^{-1} x + \frac{1}{2} \ln(1+x^2)$$

$$(12) \text{ (a) } \int x \sin^{-1} x \, dx = \frac{x^2}{2} \sin^{-1} x - \frac{1}{2} \int \frac{x^2}{\sqrt{1-x^2}} \, dx$$

$$\text{Put } x = \sin u \text{ in } \int \frac{x^2}{\sqrt{1-x^2}} \, dx = \int \frac{\sin^2 u}{\cos u} \cos u \, du$$

$$= \int \sin^2 u \, du = \int \frac{1 - \cos 2u}{2} \, du$$

$$= \frac{1}{2} u - \frac{1}{4} \sin 2u + c = \frac{1}{2} u - \frac{1}{2} \sin u \cos u + c$$

$$= \frac{1}{2} [\sin^{-1} x - x \cos (\sin^{-1} x)] + c$$

$$\therefore \int x \sin^{-1} x \, dx = \frac{x^2}{2} \sin^{-1} x - \frac{1}{4} [\sin^{-1} x - x \sqrt{1-x^2}] + c$$

$$(b) \int \ln(1+x^2) \, dx = \int 1 \cdot \ln(1+x^2) \, dx = x \ln(1+x^2) - \int \frac{2x^2}{1+x^2} \, dx$$

$$= \ln(1+x^2) - \int 2 \left[1 - \frac{1}{1+x^2} \right] \, dx = x \ln(1+x^2) - 2[x - \tan^{-1} x] + c$$

$$(13) \text{ (a) } \frac{1}{20} a^{2x} (2 \cos 4x + 4 \sin 4x) + c \text{ (b) } \frac{1}{18} e^{3x} (3 \sin 3x - 3 \cos 3x) + c$$

$$(c) \int e^{4x} \cos x \cos 2x \, dx = \frac{1}{2} \int e^{4x} (\cos 3x + \cos x) \, dx = \frac{1}{2} [\int e^{4x} \cos 3x \, dx +$$

$$\int e^{4x} \cos x \, dx] = \frac{1}{2} \left[\frac{1}{25} e^{4x} (4 \cos 3x + 3 \sin 3x) + \frac{1}{17} e^{4x} (4 \cos x + \sin x) \right] + c$$

$$(d) \int e^{2x} \cos^2 x \, dx = \int e^{2x} \left(\frac{\cos 2x + 1}{2} \right) \, dx = \frac{1}{2} [\int e^{2x} \cos 2x \, dx + \int e^{2x} \, dx]$$

$$= \frac{1}{7} \left[\frac{1}{8} e^{2x} (2 \cos 2x + 2 \sin 2x) + \frac{1}{2} e^{2x} \right] + c$$

$$(e) \int \cosh ax \sin bx \, dx = \int \left(\frac{e^{ax} + e^{-ax}}{2} \right) \sin bx \, dx = \frac{1}{2} \left[\int e^{ax} \sin bx \, dx + \int e^{-ax} \sin bx \, dx \right] = \frac{1}{2(a^2 + b^2)} [e^{ax} (a \sin bx - b \cos bx) + e^{-ax} (-a \sin bx - b \cos bx)] + c$$

$$(f) \int x e^{ax} \sin bx \, dx = x \int e^{ax} \sin bx \, dx - \int \frac{1}{a^2 + b^2} e^{ax} (a \sin bx - b \cos bx) \, dx$$

$$= \frac{x}{a^2 + b^2} e^{ax} (a \sin bx - b \cos bx) - \frac{1}{(a^2 + b^2)^2} [a e^{ax} (a \sin bx - b \cos bx) - b e^{ax} (a \cos bx + b \sin bx)] + c$$

$$(14) (a) \int \sqrt{a^2 + x^2} \, dx = x \sqrt{a^2 + x^2} - \int \frac{x^2}{\sqrt{a^2 + x^2}} \, dx$$

$$= x \sqrt{a^2 + x^2} - \int \frac{a^2 + x^2}{\sqrt{a^2 + x^2}} \, dx + \int \frac{a^2}{\sqrt{a^2 + x^2}} \, dx$$

$$= x \sqrt{a^2 + x^2} + a^2 \ln \frac{x + \sqrt{a^2 + x^2}}{a} - \int \sqrt{a^2 + x^2} \, dx + c$$

$$\therefore \int \sqrt{a^2 + x^2} \, dx = \frac{x}{2} \sqrt{a^2 + x^2} + \frac{a^2}{2} \ln \frac{x + \sqrt{a^2 + x^2}}{a} + c$$

$$(b) x \int \sqrt{x^2 - a^2} \, dx = x \sqrt{x^2 - a^2} - \int \frac{x^2}{\sqrt{x^2 - a^2}} \, dx$$

$$= x \sqrt{x^2 - a^2} - \int \sqrt{x^2 - a^2} \, dx - \int \frac{a^2}{\sqrt{x^2 - a^2}} \, dx$$

$$\therefore \int \sqrt{x^2 - a^2} \, dx = \frac{1}{2} x \sqrt{x^2 - a^2} - \frac{a^2}{2} \ln \frac{x + \sqrt{x^2 - a^2}}{a} + c$$

$$(15) (a) \frac{x^4}{2} + x^2 + 3x + c$$

$$(b) \frac{x^2}{2} + 2 \ln |x| + c$$

$$(a) \frac{1}{2} \cosh x + c$$

$$(d) \frac{e^{2x}}{2} - 2x - \frac{e^{-2x}}{2} + c$$

$$(b) \left. \frac{2}{3} \sqrt{x^3 + 1} \right]_2^4 = \frac{2}{3} (\sqrt{65} - \sqrt{9}) \quad (f) \frac{-1(x^2 + 2)}{2} + c$$

$$(f) -e^{\cos x} + c \quad (h) \frac{1}{3} \tan^{-1}(3x) + c$$

$$(i) \int_0^{\pi/2} \frac{\sin x \cos x}{(1 + \sin x)^3} dx =$$

$$(j) \int (x^2 + 2)^6 x^3 dx = \frac{1}{2} \int t^6 (t-2) dt$$

$$= \frac{1}{2} \left[\int t^7 dt - 2 \int t^6 dt \right] = \frac{t^8}{16} - \frac{t^7}{7} + c$$

$$= \frac{(x^2 + 2)^8}{16} - \frac{(x^2 + 2)^7}{7} + c$$

$$(k) \int x \sqrt{x^4 + 2x^2 + 2} dx = \int x \sqrt{(x^2 + 1)^2 + 1} dx \frac{1}{2} \int \sqrt{t^2 + 1} dt$$

$$= \frac{1}{4} t \sqrt{1 + t^2} + \frac{1}{4} \sinh^{-1} t + c = \frac{1}{4} (x^2 + 1) \sqrt{x^4 + 2x^2 + 2} + \frac{1}{4} \sinh^{-1} (x^2 + 1) + c$$

$$(l) \int \frac{x \tan^{-1} x}{(1 + x^2)^{3/2}} dx = \int \theta \sin \theta d\theta, \text{ if } x = \tan \theta$$

$$= -\theta \cos \theta + \int \cos \theta d\theta \text{ (integration by parts)} = -\theta \cos \theta + \sin \theta + c$$

$$(m) \text{ Put } x = \tan \theta \text{ in } \int \cos^{-1} \left(\frac{1 - x^2}{1 + x^2} \right) dx = 2[\theta \tan \theta + \ln |\cos \theta|] + c$$

where $\theta = \tan^{-1} x$

$$(n) \int e^x (\ln \sin x + \cot x) dx = \int e^x \ln \sin x dx + \int e^x \cot x dx$$

$$= \ln \sin x e^x - \int \cot x e^x dx + \int e^x \cot x dx = e^x \ln \sin x.$$

$$(16) \int u \frac{d^2 v}{dx^2} dx = u \frac{dv}{dx} - \int \frac{du}{dx} v dx + \int v \frac{d^2 u}{dx^2} dx$$

$$\int x^3 \sin x \, dx = \int x^3 \frac{d^2}{dx^2}(-\sin x) dx = -x^3 \cos x + 3x^2 \sin x - 6$$

$$\int x \sin x \, dx$$

$$= -x^3 \cos x + 3x^2 \sin x - 6 [-x \cos x + \int \cos x \, dx] = -x^3 \cos x + 3x^2 \sin x + 6(x \cos x - \ln x) + c$$

1.9 Terminal Questions and Answers

(1) Evaluate

i. $\int \frac{x dx}{1+x^4}$

ii. $\int \frac{e^{m \sin \theta^{-1} x}}{\sqrt{1-x^2}} dx$

iii. $\int \frac{x + \sin x}{1 + \cos x} dx$

iv. $\int \frac{1-x}{1+x} dx$

v. $\int \sqrt{1 + \sin x} dx$

UNIT-2

REDUCTION FORMULAS

Structure

- 2.1. Introduction
- 2.2. Objective
- 2.3. Reduction formula
- 2.4. Integrals Involving trigonometric functions
 - 2.4.1. Reduction Formulas for $\int \sin^n x \, dx$ and $\int \cos^n x \, dx$
 - 2.4.2. Reduction Formulas for $\int \tan^n x \, dx$ and $\int \sec^n x \, dx$
- 2.5. Integrals involving products of trigonometric functions
 - 2.5.1. Integrand of the Type $\sin^m x \cos^n x$
 - 2.5.2. Integrand of the type $e^{ax} \sin x$
- 2.6. Integrals Involving Hyperbolic Functions
- 2.7. Summary
- 2.8. Terminal Questions

2.1 Introduction

In this unit we have introduced the concept of a definite integral and have obtained the values of integrals of some standard forms. We have also studied two important methods of evaluating integrals, namely, the method of substitution and the method of integration by parts. In the solution of many physical or engineering problems, we have to integrate some integrands involving powers or products of trigonometric functions. In this unit we shall devise a quicker method for evaluating these integrals. We shall consider some standard form of integrands one by one, and derive formulas to integrate them.

The integrands which we will discuss here have one thing in common. They depend upon an integer parameter. By using the method of integration by parts we shall try to express such an integral in terms of another similar integral with a lower value of the parameter. We will see that by the repeated use of this technique, we shall be able to evaluate the given integral.

2.2 Objective

- Study of $\int x^n e^x dx$
- Study of $\int \sin^n x dx, \int \cos^n x dx, \int \tan^n x dx$, etc.
- Study of $\int \sin^m x \cos^n x dx$
- Study of $\int e^{ax} \sin^n x dx$
- Study of $\int \sinh^n x dx, \int \cosh^n x dx$

2.3 Reduction Formula

Sometimes the integrand is not only a function of the independent variable, but it also depends upon a number n (usually an integer). For example, in $\int \sin^n x dx$, the integrand $\sin^n x$ depends on x and n . Similarly, in $\int e^x \cos^m x dx$ depends on x and m . The numbers n and m in these two examples are called parameters. We shall discuss only integer parameter here. On integrating by parts we sometimes obtain the value of the given integral in terms of another similar integral in which the parameter has a smaller value. Thus, after a number of steps we might arrive at an integrand which can be readily evaluated. Such a process is called the method of successive reduction, and a formula connecting an integral with parameter n to a similar integral with a lower value of the parameter, is called a reduction formula.

Definition 1: A formula of the form $\int f(x, n) dx = g(x) + \int f(x, k) dx$.

where $k < n$, is called a reduction formula.

Example 1: The integrand in $\int x^n e^x dx$ depends on x and also on the parameter n which is the exponent of x , Let $I_n = \int x^n e^x dx$.

Integrating this by parts, with x^n as the first function and e^x as the second function gives us $I_n = x^n \int e^x dx - \int (nx^{n-1} \int e^x dx) dx = x^n e^x - n \int (x^{n-1} e^x) dx$

Note that the integrand in the integral on the right hand side is similar to the one we started with. The only difference is that the exponent of x is $n - 1$. Or, we can say that the exponent of x is reduced by 1, Thus, we can write

$I_n = x^n e^x - n I_{n-1}$. ----- (1). The formula (1) is a reduction gives us

$$\int x^4 e^x dx = x^4 e^x - 4x^3 e^x - 12x^2 e^x + 24xe^x + 24e^x + c$$

in five simple steps. This became possible because of formula (1). In this unit we shall derive many such reduction formulas. These fall into three main categories according as the integrand

- (i) A power of trigonometric functions.
- (ii) A product of trigonometric function, and
- (iii) Involves hyperbolic functions.

2.4 Integrals involving Trigonometric Function

There are many occasions when we have to integrate powers of trigonometric functions. In this section we shall indicate how to proceed in such cases.

2.4.1 Reduction Formulas for $\int \sin^n x \, dx$

In this sub-section we will consider integrands which are powers of either $\sin x$ or $\cos x$. Let us take a power of $\sin x$ first. For evaluating $\int \sin^n x \, dx$, we write

$$\begin{aligned} I_n &= \int \sin^n x \, dx \\ &= \int \sin^{n-1} x \cdot \sin x \, dx, \text{ if } n > 1. \end{aligned}$$

Taking $\sin^{n-1} x$ as the first function and $\sin x$ as the second and then integrating by parts, we get $I_n = \sin^{n-1} x (-\cos x) - (n-1) \int \sin^{n-2} x \cos x (-\cos x) \, dx$

$$\begin{aligned} &= -\sin^{n-1} x \cos x + (n-1) \int \sin^{n-2} x \cos^2 x \, dx \\ &= -\sin^{n-1} x \cos x + (n-1) \int [\sin^{n-2} x (1 - \sin^2 x)] \, dx \\ &= -\sin^{n-1} x \cos x + (n-1) [\int \sin^{n-2} x \, dx - \int \sin^n x \, dx] \\ &= -\sin^{n-1} x \cos x + (n-1) [I_{n-2} - I_n] \end{aligned}$$

Hence, $I_n + (n-1) I_n = -\sin^{n-1} x \cos x + (n-1) I_{n-2}$

$$nI_n = -\sin^{n-1} x \cos x + (n-1)I_{n-2}$$

$$\text{or } I_n = \frac{-\sin^{n-1} x \cos x}{n} + \frac{n-1}{n} I_{n-2}$$

Hence the reduction formula for $\int \sin^n x \, dx$ is

$$I_n = \int \sin^n x \, dx = \frac{-\sin^{n-1} x \cos x}{n} + \frac{n-1}{n} \int \sin^{n-2} x \, dx, \text{ This is (value for } n \geq 2) \dots \dots (1)$$

$$I_n = \int \sin^n x dx = \frac{-\sin^{n-1} x \cos x}{n} + \frac{n-1}{n} I_{n-2}$$

Now evaluate the definite integral $\int_0^{\frac{\pi}{2}} \sin^n x dx$

With the help of reduction formula (1) we can write

$$\begin{aligned} \int_0^{\frac{\pi}{2}} \sin^n x dx &= \left[-\frac{\sin^{n-1} x \cos x}{n} \right]_0^{\frac{\pi}{2}} + \frac{n-1}{n} \int_0^{\frac{\pi}{2}} \sin^{n-2} x dx \\ &= \frac{n-1}{n} \int_0^{\frac{\pi}{2}} \sin^{n-2} x dx \quad \text{because } \sin 0 = 0, \text{ and } \cos 0 = 1. \end{aligned}$$

$$I_n = \frac{n-1}{n} I_{n-2} \dots \dots \dots (2)$$

$$\text{i.e. } \int_0^{\frac{\pi}{2}} \sin^n x dx = \frac{n-1}{n} \int_0^{\frac{\pi}{2}} \sin^{n-2} x dx \dots \dots \dots (3)$$

Replacing n by n-2 in equation (2), we have

$$I_{n-2} = \frac{(n-2)-1}{n-2} I_{n-2-2} = \frac{(n-3)}{n-2} I_{n-4} \dots \dots \dots (4)$$

again replaing n = n-2 in equation (4), we have

$$I_{n-4} = \frac{(n-5)}{n-4} I_{n-6} \dots \dots \dots \text{and so on.}$$

$$\text{Then we have } I_n = \left(\frac{n-1}{n} \right) \left(\frac{n-3}{n-2} \right) \left(\frac{n-5}{n-4} \right) I_{n-6}$$

So

$$\int_0^{\frac{\pi}{2}} \sin^n x dx = \begin{cases} \left(\frac{n-1}{n} \right) \left(\frac{n-3}{n-2} \right) \left(\frac{n-5}{n-4} \right) \dots \dots \dots \frac{4}{5} \cdot \frac{2}{3} \int_0^{\frac{\pi}{2}} \sin x dx, & \text{if } n \text{ is an odd no. and } n \geq 3 \\ \left(\frac{n-1}{n} \right) \left(\frac{n-3}{n-2} \right) \left(\frac{n-5}{n-4} \right) \dots \dots \dots \frac{3}{4} \cdot \frac{1}{2} \int_0^{\frac{\pi}{2}} dx, & \text{if } n \text{ is an even no. and } n \geq 2 \end{cases}$$

.....(5)

$$\text{Since we have } I_n = \int \sin^n x dx = \frac{-\sin^{n-1} x \cos x}{n} + \frac{n-1}{n} I_{n-2}$$

Putting n = 3 in above equation, we get

$$\begin{aligned}
\int \sin^3 x dx &= \frac{-\sin^{3-1} x \cos x}{3} + \frac{3-1}{3} I_{3-2} \\
&= \frac{-\sin^2 x \cos x}{3} + \frac{2}{3} I_1 \\
&= \frac{-\sin^2 x \cos x}{3} + \frac{2}{3} \int \sin x dx \\
&= \frac{-\sin^2 x \cos x}{3} - \frac{2}{3} \cos x
\end{aligned}$$

Similarly, putting $n=4$ we have

$$\begin{aligned}
\int \sin^4 x dx &= \frac{-\sin^{4-1} x \cos x}{4} + \frac{4-1}{4} I_{4-2} \\
&= \frac{-\sin^3 x \cos x}{4} + \frac{3}{4} \int \sin^2 x dx \\
&= -\frac{\sin^3 x \cos x}{4} + \frac{3}{4} \left[-\frac{\sin x \cos x}{2} + \frac{1}{2} \int \sin^0 x dx \right] \\
&= -\frac{\sin^3 x \cos x}{4} - \frac{3}{8} \sin x \cos x + \frac{3}{8} x
\end{aligned}$$

Example 1: We shall now use the reduction formula for $\int \sin^n x dx$ to evaluate the definite integral $\int_0^{\pi/2} \sin^5 x dx$.. We first observe that

$$\int_0^{\pi/2} \sin^n x dx = \left[\frac{-\sin^{n-1} x \cos x}{n} \right] + \frac{n-1}{n} \int_0^{\pi/2} \sin^{n-2} x dx = \frac{n-1}{n} \int_0^{\pi/2} \sin^{n-2} x dx, n \geq 2.$$

$$\begin{aligned}
\text{Thus, } \int_0^{\pi/2} \sin^5 x dx &= \frac{4}{5} \int_0^{\pi/2} \sin^3 x dx = \frac{4}{5} \cdot \frac{2}{3} \int_0^{\pi/2} \sin x dx \\
&= \frac{8}{15} (-\cos x) \Big|_0^{\pi/2} = \frac{8}{15}
\end{aligned}$$

2.4.2 Reduction Formulas for $\int \cos^n x dx$

To find a reduction Formulas for $\int \cos^n x dx$ where n is a positive integer and also deduced $\int_0^{\pi/2} \cos^n x dx$

Method 1: By property of definite integral, we have

$$\int_0^a f(x) dx = \int_0^a f(a-x) dx$$

$$\begin{aligned} \text{i.e. } \int_0^{\frac{\pi}{2}} \sin^n x dx &= \int_0^{\frac{\pi}{2}} \sin^n \left(\frac{\pi}{2} - x \right) dx \\ &= \int_0^{\frac{\pi}{2}} \cos^n x dx \end{aligned}$$

Therefore from equation (5), we have

$$\int_0^{\frac{\pi}{2}} \cos^n x dx = \int_0^{\frac{\pi}{2}} \sin^n x dx = \begin{cases} \left(\frac{n-1}{n} \right) \left(\frac{n-3}{n-2} \right) \left(\frac{n-5}{n-4} \right) \dots \frac{4}{5} \cdot \frac{2}{3} \cdot 1, & \text{if } n \text{ is an odd no.} \\ \left(\frac{n-1}{n} \right) \left(\frac{n-3}{n-2} \right) \left(\frac{n-5}{n-4} \right) \dots \frac{3}{4} \cdot \frac{1}{2} \cdot \frac{\pi}{2}, & \text{if } n \text{ is an even no.} \end{cases}$$

Method 2:

Let us now derive the reduction formula for $\int \cos^n x dx$. Again let us write

$I_n = \int \cos^n x dx = \int \cos^{n-1} x \cos x dx$, $n > 1$. Integrating this integral by parts we get

$$\begin{aligned} I_n &= \int \cos^{n-1} x \sin x - \int (n-1) \cos^{n-2} x (-\sin x) \cdot \sin x dx \\ &= \cos^{n-1} x \sin x + (n-1) \int \cos^{n-2} x \sin^2 x dx \\ &= \cos^{n-1} x \sin x + (n-1) \int \cos^{n-2} x (1 - \cos^2 x) dx = \cos^{n-1} x \sin x + (n-1) \\ & \quad (I_{n-2} - I_n) \end{aligned}$$

By rearranging the terms we get $I_n = \int \cos^n x dx = \frac{\cos^{n-1} x \sin x}{n} + \frac{n-1}{n} I_{n-2}$

This formula is valid for $n \geq 2$. What happens when $n = 0$ or 1 ?

As we have $\int_0^{\pi/2} \sin^n x dx = \frac{n-1}{n} \int_0^{\pi/2} \sin^{n-2} x dx$, $n \geq 2$. Using this formula repeatedly we get

$$\int_0^{\pi/2} \sin^n x dx = \begin{cases} \frac{n-1}{n} \cdot \frac{n-3}{n-2} \cdot \frac{n-5}{n-4} \dots \frac{4}{5} \cdot \frac{2}{3} \int \sin x dx, & \text{if } n \text{ is an odd number, } n \geq 3. \\ \frac{n-1}{n} \cdot \frac{n-3}{n-2} \cdot \frac{n-5}{n-4} \dots \frac{3}{4} \cdot \frac{1}{2} \int_0^{\pi} dx, & \text{if } n \text{ is an even number, } n \geq 2. \end{cases}$$

This means

$$\int_0^{\pi/2} \sin^n x dx = \begin{cases} \frac{n-1}{n} \cdot \frac{n-3}{n-2} \dots \frac{4}{5} \cdot \frac{2}{3} \int & \text{if } n \text{ is an odd number, } n \geq 3. \\ \frac{n-1}{n} \cdot \frac{n-3}{n-2} \dots \frac{3}{4} \cdot \frac{1}{2} \cdot \frac{\pi}{2}, & \text{if } n \text{ is even } n \geq 2 \end{cases}$$

We can reverse the order of the factors, and write this as

$$\int_0^{\pi/2} \sin^n x dx = \begin{cases} \frac{2}{3} \cdot \frac{4}{5} \cdots \frac{n-3}{n-2} \cdot \frac{n-1}{n} & \text{if } n \text{ is odd, } n \geq 3 \\ \frac{1}{2} \cdot \frac{3}{4} \cdots \frac{n-1}{n} \cdot \frac{\pi}{2} & \text{if } n \text{ is even, } n \geq 2 \end{cases}$$

Arguing similarly for $\int_0^{\pi/2} \cos^n x dx$ we get

$$\int_0^{\pi/2} \cos^n x dx = \int_0^{\pi/2} \sin^n x dx = \begin{cases} \frac{2}{3} \cdot \frac{4}{5} \cdots \frac{n-1}{n} & \text{if } n \text{ is odd, and } n \geq 3 \\ \frac{1}{2} \cdot \frac{3}{4} \cdots \frac{n-1}{n} \cdot \frac{\pi}{2} & \text{if } n \text{ is even, } n \geq 2 \end{cases}$$

Check your progress

(1) Prove $\int_0^{\pi/2} \cos^n x dx = \begin{cases} \frac{2}{3} \cdot \frac{4}{5} \cdots \frac{n-1}{n} & \text{if } n \text{ is odd, } n \geq 3 \\ \frac{1}{2} \cdot \frac{3}{4} \cdots \frac{n-1}{n} \cdot \frac{\pi}{2} & \text{if } n \text{ is even, } n \geq 2 \end{cases}$

(2) Evaluate (a) $\int_0^{\pi/2} \cos^2 x dx$, (b) $\int_0^{\pi/2} \cos^6 x dx$, using the reduction formula

2.4.2 Reduction Formulas for $\int \tan^n x dx$ and $\int \sec^n x dx$

In this sub-section we will take up two other trigonometric functions $\tan x$ and $\sec x$. This is, we will derive the reduction formulas for $\int \tan^n x dx$, $n > 2$. We start in a slightly different manner. Instead of writing $\tan^n x = \tan x \tan^{n-1} x$, as we did in the case of $\sin^n x$, we shall write $\tan^n x = \tan^{n-2} x \cdot \tan^2 x$.

So we write $I_n = \int \tan^n x dx$

$$= \int \tan^{n-2} x \tan^2 x dx = \int \tan^{n-2} x (\sec^2 x - 1) dx = \int \tan^{n-2} x \sec^2 x dx - \int \tan^{n-2} x dx \quad \text{---(2)}$$

We must have observed that the second integral on the right hand side is I_{n-2} . Now in the first integral on the right hand side, the integrand is of the form

$$[f(x)]^m f'(x) dx = \frac{[f(x)]^{m+1}}{m+1} + c$$

This $\int \tan^{n-2} x \sec^2 x dx = \frac{\tan^{n-1} x}{n-1} + c$. Therefore, (2) give

$$I_n = \frac{\tan^{n-1} x}{n-1} - I_{n-2}$$

Thus the reduction formula for $\int \tan^n x \, dx = I_n = \frac{\tan^{n-1} - 1}{n-1} - I_{n-2}$

To derive the reduction formula for $\int \sec^n x \, dx$ ($n > 2$). We first write $\sec^n x = \sec^{n-2} x \sec^2 x$, and then integrate by parts. Thus

$$\begin{aligned} I_n &= \int \sec^n x \, dx = \int \sec^{n-2} x \sec^2 x \, dx = \sec^{n-2} x \tan x - (n-2) \int \sec^{n-3} x \sec x \tan^2 x \, dx \\ &= \sec^{n-2} x \tan x - (n-2) \int \sec^{n-2} x \tan^2 x \, dx \\ &= \sec^{n-2} x \tan x - (n-2) \int \sec^{n-2} x (\sec^2 x - 1) \, dx = \sec^{n-2} x \tan x - (n-2) (I_n - I_{n-2}) \end{aligned}$$

After rearranging the terms we get $\int \sec^n x \, dx = I_n = \frac{\sec^{n-2} x \tan x}{n-1} + \frac{n-2}{n-1} I_{n-2}$

These formulas $\int \tan^n x \, dx$ and $\int \sec^n x \, dx$ are valid for $n > 2$. For $n = 0, 1$ and 2 , the integral $\int \tan^n x \, dx$ and $\int \sec^n x \, dx$ can be easily evaluated.

Example 3: Let's calculate (i) $\int_0^{\pi/4} \tan^5 x \, dx$ and (ii) $\int_0^{\pi/4} \sec^6 x \, dx$

$$\begin{aligned} \text{(i)} \quad \int_0^{\pi/4} \tan^5 x \, dx &= \left. \frac{\tan^4 x}{4} \right]_0^{\pi/4} - \int_0^{\pi/4} \tan^3 x \, dx \\ &= \left. \frac{1}{4} - \frac{\tan^2 x}{x} \right]_0^{\pi/4} + \int_0^{\pi/4} \tan x \, dx \\ &= \frac{1}{4} - \frac{1}{2} + \int_0^{\pi/4} \frac{\sin x}{\cos x} \, dx = \frac{1}{4} - \ln(\cos x) \Big|_0^{\pi/4} = \frac{1}{4} - \ln \frac{1}{\sqrt{2}} + \ln 1 \\ &= -\frac{1}{4} \ln \sqrt{2} \end{aligned}$$

$$\begin{aligned} \text{(ii)} \quad \int_0^{\pi/4} \sec^6 x \, dx &= \left. \frac{\sec^4 x \tan x}{5} \right]_0^{\pi/4} + \left. \frac{2}{3} \int_0^{\pi/4} \sec^2 x \, dx \right\} \\ &= \frac{4}{5} + \frac{8}{15} + \frac{8}{15} \int_0^{\pi/4} \sec^2 x \, dx \\ &= \frac{4}{3} + \frac{8}{15} \tan x \Big|_0^{\pi/4} = \frac{28}{15} \end{aligned}$$

2.5 Integrals Involving products of trigonometric functions

In this section we have seen the reduction formulas for the case where integrands were powers of a single trigonometric function. Here we shall consider some integrands involving products of powers of trigonometric functions. The technique of finding a reduction formulas basically involves integration by parts. Since there can be more than one way of writing the integrand as a product of two functions, we will see that we can have many reduction formulas for the same integrals.

2.5.1 Integrand of the Type $\sin^m x \cos^n x$

The function $\sin^m x \cos^n x$ depends on two parameters m and n . To find a reduction formula for $\int \sin^m x \cos^n x dx$, let us first write $I_{m,n} = \int \sin^m x \cos^n x dx$

Since we have two parameters here, we shall take a reduction formula mean a formula connecting $I_{m,n}$ and $I_{p,q}$, where either $p < m$, or $q < n$, or both $p < m$, $q < n$ hold. In other words, the value of at least one parameter should be reduced.

$$\text{If } n = 1, I_{m,1} = \int \sin^m x \cos x dx \begin{cases} \frac{\sin^{m+1} x}{m+1} + c, & \text{when } m \neq -1 \\ \ln |\sin x| + c, & \text{when } m = -1 \end{cases}$$

Hence we assume that $n > 1$. Now,

$$I_{m,n} = \int \sin^m x \cos^n x dx = \int \cos^{n-1} x (\sin^m x \cos x) dx$$

Integrating by parts we get

$$I_{m,n} = \frac{\cos^{n-1} x \cdot \sin^{m+1} x}{m+1} - \int (n-1) \cos^{n-2} x (-\sin x) \frac{\sin^{m+1} x}{m+1} dx, \text{ if } m \neq -1$$

1.

$$= \frac{\cos^{n-1} x \cdot \sin^{m+1} x}{m+1} + \frac{n-1}{n+1} \int \sin^m x \cos^{n-2} x (1 - \cos^2 x) dx$$

$$= \frac{\cos^{n-1} x \cdot \sin^{m+1} x}{m+1} + \frac{n-1}{m+1} [I_{m,n-2} - I_{m,n}]. \text{ Therefore,}$$

$$I_{m,n} + \frac{n-1}{m+1} I_{m,n} = \frac{m+n}{m+1} I_{m,n} = \frac{\cos^{n-1} x \sin^{m+1} x}{m+1} + \frac{n-1}{n+1} I_{m,n-2}$$

$$\text{This gives us, } I_{m,n} = \frac{\cos^{n-1} x \sin^{m+1} x}{m+1} + \frac{n-1}{m+n} I_{m,n-2}$$

.... (3)

But, surely this formula will not work if $m+n=0$. So, what do we do if $m+n=0$? Actually we have a simple way out. If $m+n=0$, then since, n is positive, we write $m=-n$.

Hence $I_{-n,n} = \int \sin^{-n} x \cos^n x dx = \int \cot^n x dx$, which is easy to evaluate using the reduction formula.

To obtain $\int \sin^m x \cos^n x dx = \int \sin^{m-1} x (\cos^n x \sin x) dx$. Integrating this by parts we get

$$I_{m,n} = \frac{-\sin^{m-1} x \cos^{n+1} x}{n+1} - (m-1) \int \sin^{m-2} x \cos x \frac{(-\cos^{n+1} x)}{n+1} dx \text{ for } n \neq -1.$$

$$= \frac{-\sin^{m-1} x \cos^{n+1} x}{n+1} + \frac{m-1}{n+1} \int \sin^{m-2} x \cos^n x \cos x (1 - \sin^2 x) dx$$

$$= -\frac{\sin^{m+1} x \cos^{n+1} x}{n+1} + \frac{m-1}{n+1} (I_{m-2,n}, I_{m,n}). \text{ Form this we obtain}$$

$$I_{m,n} = \frac{-\sin^{m-1} x \cos^{n+1} x}{m+n} + \frac{m-1}{m+n} (I_{m-2,n}) \dots\dots\dots (4)$$

If m or n is a positive odd integer, we can proceed as follows:

Suppose $m = 2p + 1, p > 0$, then $I_{m,n} = \int \sin^m x \cos^{2p+1} x dx$

$$= \int \sin^m x (1 - \sin^2 x)^p \cos x dx = \int t^m (1 - t^2)^p dt \text{ we put } t = \sin x$$

Expanding $(1 - t^2)^p$ by binomial theorem and integrating term by term, we get

$$I_{m,n} = \frac{t^{m+1}}{m+1} - (p,1) \frac{t^{m+3}}{m+3} - C(p,2) \frac{t^{m+5}}{m+5} \dots\dots\dots + \frac{(-1)^p t^{m+2p+1}}{m+2p+1} + c$$

$$= \frac{\sin^{m+1} x}{m+1} - C(p,1) \frac{\sin^{m+3} x}{m+3} + C(p,2) \frac{\sin^{m+5} x}{m+5} - \dots\dots\dots + \frac{(-1)^n \sin^{m+2p+1} x}{m+2p+1} + c$$

If m and n are positive integers, by repeated applications of formula (3) or formula (4), we keep reducing n or m by 2 at each step. Thus, eventually, we come integral of the form $I_{m,0}$ or $I_{m,1}$ or $I_{1,n}$ or $I_{0,n}$. In the previous section we have seen how these can be evaluated. This means we should be able to evaluate $I_{m,n}$ in a finite number of steps.

Example4: Let us evaluate

$$\int_0^{\pi/2} \sin^4 x \cos^6 x dx = \left. \frac{-\sin^3 x \cos^7 x}{10} \right]_0^{\pi/2} + \frac{3}{10} \int_0^{\pi/2} \sin^2 x \cos^6 x dx$$

$$= \frac{3}{10} \int_0^{\pi/2} \sin^2 x \cos^6 x dx = \frac{3}{10} \left\{ \left. \frac{-\sin x \cos^7 x}{8} \right]_0^{\pi/2} + \frac{1}{8} \int_0^{\pi/2} \cos^6 x dx \right\}$$

Using formula (4) again $= \frac{3}{80} \int_0^{\pi/2} \cos^6 x dx = \frac{3}{80} \times \frac{15\pi}{96} = \frac{3\pi}{512}$

Check your progress

(3) Derive the following reduction formulas for $\int \cot^n x dx$ and $\int \operatorname{cosec}^n x dx$

(a) $\int \cot^n x dx = I_n = \frac{-1}{n-1} \cot^{n-1} x - I_{n-2}$

(b) $\int \operatorname{cosec}^n x dx = I_n = \frac{-\operatorname{cosec}^{n-2} x \cot x}{n-1} + \frac{n-2}{n-1} I_{n-2}$

(4) Evaluate (a) $\int_{\pi/2}^{\pi/2} \operatorname{cosec}^3 x dx$ (b) $\int_0^{\pi/2} \sin^8 x dx$ (c) $\int \sec^3 \theta d\theta$

(5) In deriving formula (4) we had assumed that $m > 1$. How would you evaluate, $I_{m,n}$ if $m = 1$?

(6) Formulas (3) and (4) fail when $m+n=0$. We have seen how to evaluate $I_{m,n}$ if $m+n=0$ and n is a positive integer. How would we evaluate it if $m+n=0$ and n is negative integer.

(7) Evaluate (a) $\int_0^{\pi/2} \sin^3 x \cos^5 x dx$ (b) $\int_0^{\pi/2} \sin^8 x \cos^2 x dx$

2.5.2 Integrand of the Type $e^{ax} \sin^n x$

In this sub-section we will consider the evaluation of those integrals, where the integrand is a product of a power of a trigonometric function and an exponential function. That is, we will consider integrands of the type $e^{ax} \sin^n x$. Let us denote

$\int e^{ax} \sin^n x dx$ by L_n , and integrate it by parts, taking $\sin^n x$ as the first function and e^{ax} as the second function. This gives us

$$L_n = \frac{e^{ax} \sin^n x}{a} - \frac{n}{a} \int e^{ax} \sin^{n-1} x \cos x dx$$

We shall now evaluate the integral on the right hand side, again by parts, with

$\sin^{n-1} \cos x$ as the first function and e^{ax} as the second one. Thus,

$$\begin{aligned} L_n &= \frac{e^{ax} \sin^n x}{a} - \frac{n}{a} \left[\frac{a^{ax} \sin^{n-1} x \cos x}{a} - \frac{1}{a} \int e^{ax} \{(n-1) \sin^{n-2} x \cos^2 x - \sin^n x\} dx \right] \\ &= \frac{e^{ax} \sin^n x}{a} - \frac{n}{a} \left[\frac{a^{ax} \sin^{n-1} x \cos x}{a} - \frac{1}{a} \int e^{ax} \{(n-1) \sin^{n-2} x - n \sin^n x\} dx \right] \end{aligned}$$

This means

$$L_n = \frac{e^{ax} \sin^n x}{a} - \frac{ne^{ax} \sin^{n-1} x \cos x}{a^2} + \frac{n(n-1)}{a^2} L_{n-2} - \frac{n^2}{a^2} L_n$$

Rearranging the terms we get

$$L_n = \frac{ae^{ax} \sin^n x}{n^2 + a^2} - \frac{ne^{ax} \sin^{n-1} x \cos x}{n^2 + a^2} L_{n-2}$$

Given any L_n , we use this reduction formulas repeatedly, till we get L_1 or L_0 (depending on whether n is odd or even). Since L_1 and L_0 are easy to evaluate, we are sure we can evaluate them (see E8). This means that L_n can be evaluated for any positive integer n .

Remark 1 If we put $a = 0$ in L_n , it reduce to the integral $\int \sin^n x dx$. This suggest that the reduction formula for $\int \sin^n x dx$ which we have derived is a special case of the reduction formula for I_n .

Check your progress

(8) Prove that (a) $L_0 = \frac{e^{ax}}{a} + c$ (b)

$$L_1 = \int e^{ax} \sin x dx = \frac{e^{ax}}{1+a^2} (a \sin x - \cos x) + c$$

(9) Prove : If $C_n = \int e^{ax} \cos^n x dx$, then

$$C_n = \frac{ae^{ax} \cos^n x}{n^2 + a^2} + \frac{ne^{ax} \cos^{n-1} x \sin x}{n^2 + a^2} + \frac{n(n-1)}{n^2 + a^2} C_{n-2}$$

(10) Verify that the reduction formula for $\int \cos^n x dx$

(10) Verify that the reduction formula for $\int \cos^n x dx$

(11) Prove the following reduction formula:

$$\int \sinh^n x dx = \frac{\sinh^{n-1} x \cosh x}{n} - \frac{n-1}{n} \int \sinh^{n-2} x dx$$

(12) Derive a reduction formula for $\int \cosh^n x dx$

2.6 Integrals Involving Hyperbolic Functions

In this section we shall discuss the evaluation of integrals of the type

$\int \sinh^n x dx$, $\int \cosh^n x dx$, etc. If $I_n = \int \tanh^n x dx$, we can write

$$I_n = \int \tanh^{n-2} x \tanh^2 x dx = \int \tanh^{n-2} x (1 - \operatorname{sech}^2 x) dx, \\ \frac{d}{dx} \tanh x = \operatorname{sech}^2 x$$

$$= \int \tanh^{n-2} x dx - \int \tanh^{n-2} x \operatorname{sech}^2 x dx = I_{n-2} - \frac{\tanh^{n-1} x}{n-1}$$

2.7 Summary

A reduction formula is one which links an integral dependent on a parameter with a similar integral with a lower value of the parameter.

In this unit we have derived a number of reduction formulas.

1. $\int x^n e^x dx = x^n e^x - n \int x^{n-1} e^x dx$
2. $\int \sin^n x dx = \frac{-\sin^{n-1} x \cos x}{n} + \frac{n-1}{n} \int \sin^{n-2} x dx, n \geq 2$
3. $\int \cos^n x dx = \frac{4 \cos^{n-1} x \sin x}{n} + \frac{n-1}{n} \int \cos^{n-2} x dx, n \geq 2$
4. $\int \tan^n x dx = \frac{-\tan^{n-1}}{n-1} - \int \tan^{n-2} x dx, n > 2$
5. $\int \sec^n x dx = \frac{\sec^{n-2} x \tan x}{n-1} + \frac{n-2}{n-1} \int \sec^{n-3} x dx, n > 2$
6. $\int_0^{\pi/2} \sin^n x dx = \int_0^{\pi/2} \cos^n x dx = \begin{cases} \frac{2}{3} \frac{4}{5} \dots \frac{n-1}{n}, & \text{if } n \text{ is odd, } n \geq 3 \\ \frac{1}{2} \frac{3}{4} \dots \frac{n-1}{n}, & \text{if } n \text{ is even, } n \geq 2 \end{cases}$
7. $\int \sin^m x \cos^n x dx = \frac{\cos^{n-1} x \sin^{m+1} x}{m+n} + \frac{n-1}{m+n} \int \sin^m x \cos^{n-2} x dx, \\ n > 1 \\ = \frac{-\sin^{m-1} x \cos^{n-1} x}{m+n} + \frac{m-1}{m+n} \int \sin^{m-2} x \cos^n x dx, m > 1$

$$8. \int e^{ax} \sin^n x dx = \frac{ae^{ax} \sin^n x}{n-1} - \frac{ne^{ax} \sin^{n-1} x \cos x}{n^2 a^2} + \frac{n(n-1)}{n^2 + a^2} \int e^{ax} \sin^{n-2} x dx$$

$$9. \int \tanh^n x dx = \frac{-\tanh^{n-1} x}{n-1} + \int \tanh^{n-2} x dx$$

We have noted that the primary technique of deriving reduction formulas involved integration by parts. We have also observed that many more reduction formulas involving other trigonometric and hyperbolic functions can be derived using the same technique.

Solution and Answers of check your progress

(1) we have

$$\int_0^{\pi/2} \cos^n x dx = \frac{\cos^{n-1} x \sin x}{n} \Big|_0^{\pi/2} + \frac{n-1}{n} \int_0^{\pi/2} \cos^{n-2} x dx, n \geq 2$$

$$= \frac{n-1}{n} \int_0^{\pi/2} \cos^{n-2} x dx = \frac{n-1}{n} \cdot \frac{n-3}{n-2} \int_0^{\pi/2} \cos^{n-4} x dx .$$

$$= \begin{cases} \frac{n-1}{n} \cdot \frac{n-3}{n-2} \cdot \frac{n-5}{n-4} \cdots \frac{3}{4} \cdot \frac{1}{2} \int_0^{\pi/2} \cos^0 x dx, & \text{if } n \text{ is even} \\ \frac{n-1}{n} \cdot \frac{n-3}{n-2} \cdot \frac{n-5}{n-4} \cdots \frac{4}{5} \cdot \frac{2}{3} \int_0^{\pi/2} \cos x dx, & \text{if } n \text{ is odd} \end{cases}$$

$$= \begin{cases} \frac{n-1}{n} \cdot \frac{n-3}{n-2} \cdot \frac{n-5}{n-4} \cdots \frac{3}{4} \cdot \frac{1}{2} \cdot \frac{\pi}{2} & \text{if } n \text{ is even} \\ \frac{n-1}{n} \cdot \frac{n-3}{n-2} \cdot \frac{n-5}{n-4} \cdots \frac{4}{5} \cdot \frac{2}{3} & \text{if } n \text{ is odd} \end{cases}$$

(2) (a) $\int_0^{\pi/2} \cos^5 x dx = \frac{4}{5} \cdot \frac{2}{3} = \frac{8}{15}$ (b)

$$\int_0^{\pi/2} \cos^6 x dx = \frac{5}{6} \cdot \frac{3}{4} \cdot \frac{1}{2} \cdot \frac{\pi}{2} = \frac{5\pi}{32}$$

(3) (a) $I_n = \int \cot^n x dx = \int \cot^{n-2} x (\operatorname{cosec}^2 x - 1) dx, n > 2$

$$= \int \cot^{n-2} x \operatorname{cosec}^2 x dx - I_{n-2} . \text{ Therefore } I_n = \frac{-\cot^{n-1} x}{n-1} - I_{n-2}$$

(b) $I_n = \int \operatorname{cosec}^n x dx = \int \operatorname{cosec}^{n-2} x \operatorname{cosec}^2 x dx, n > 2$

$$= -\operatorname{cosec}^{n-2} x \cot x + \int (n-2) \operatorname{cosec}^{n-2} x \cot^2 x dx$$

$$= -\operatorname{cosec}^{n-2} x \cot x - (n-2) \int \operatorname{cosec}^{n-2} x \operatorname{cosec}^2 x dx = -\operatorname{cosec}^{n-2} x \cot x - (n-2) I_n + (n-2) I_{n-2}$$

$$I_n = \frac{-\operatorname{cosec}^{n-2} x \cot x}{n-1} + \frac{n-2}{n-1} I_{n-2}$$

$$(4) \quad (a) \quad \int_{\pi/4}^{\pi/4} \operatorname{cosec}^3 x dx = \frac{-\operatorname{cosec} x \cot x}{2} \Bigg|_{\pi/4}^{\pi/4} + \frac{1}{2} \int_{\pi/4}^{\pi/2} \operatorname{cosec} x dx$$

$$= \frac{1}{\sqrt{2}} + \frac{1}{2} \ln \tan \frac{x}{2} \Bigg|_{\pi/4}^{\pi/2}$$

$$= \frac{1}{\sqrt{2}} + \frac{1}{2} (\ln 1 - \ln \tan \frac{\pi}{8}) = -\frac{1}{\sqrt{2}} - \frac{1}{2} \ln \tan \frac{\pi}{8}$$

$$(b) \quad \int_0^{\pi/2} \sin^8 x dx = \frac{7}{8} \cdot \frac{5}{6} \cdot \frac{3}{4} \cdot \frac{1}{2} \cdot \frac{\pi}{2} = \frac{35\pi}{256}$$

$$(c) \quad \int \sec^3 \theta d\theta = \frac{\sec \theta \tan \theta}{2} + \frac{1}{2} \int \sec \theta d\theta = \frac{\sec \theta \tan \theta}{2} + \frac{1}{2} \ln (\sec x + \tan x) + c$$

$$(5) \quad \text{If } m = 1, I_{m,n} = I_{1,n} = \int \sin x \cos^n x dx = \begin{cases} \frac{\cos^{n+1} x}{n+1} + c \text{ if } n \neq -1 \\ -\ln |\cos x| + c \text{ if } n = -1 \end{cases}$$

(6) $m+n=0 \Rightarrow n=-m \Rightarrow m$ is a positive integer.

$$I_{m,n} = \int \sin^m x \cos^{-m} x dx = \int \frac{\sin^m x}{\cos^m x} dx = \int \tan^m x dx$$

Now use the formulas for $\int \tan^m x dx$

$$(7) \quad (a) \quad \int_0^{\pi/2} \sin^3 x \cos^5 x dx = \frac{-\sin^2 x \cos^6 x}{8} \Bigg|_0^{\pi/2} + \frac{2}{8} \int_0^{\pi/2} \sin x \cos^5 x dx$$

$$= \frac{2}{8} \int_0^{\pi/2} \sin x \cos^5 x dx = \frac{-2 \cos^6 x}{8 \cdot 6} \Bigg|_0^{\pi/2} = \frac{1}{24}$$

$$(b) \quad \int_0^{\pi/2} \sin^3 x \cos^5 x dx = \frac{-\sin^2 x \cos^6 x}{8} \Bigg|_0^{\pi/2} + \frac{1}{10} \int_0^{\pi/2} \sin^8 x dx$$

$$= \frac{1}{10} \int_0^{\pi/2} \sin^8 x dx = \frac{1}{10} \cdot \frac{7}{8} \cdot \frac{5}{6} \cdot \frac{3}{4} \cdot \frac{1}{2} \cdot \frac{\pi}{2} = \frac{7\pi}{512}$$

$$(8) \quad (a) \quad L_0 = \int e^{ax} dx = \frac{e^{ax}}{a} + c \quad (b) \quad L_1 = \int e^{ax} \sin x dx = \frac{e^{ax} \sin x}{a} - \frac{1}{a} \int e^{ax} \cos x dx$$

$\cos x dx$

$$= \frac{e^{ax} \sin x}{a} - \frac{e^{ax} \cos x}{a^2} - \frac{1}{a^2} \int e^{ax} \sin x dx$$

$$\int e^{ax} \cdot \sin x dx = \frac{ae^{ax} \sin x}{1+a^2} - \frac{e^{ax} \cos x}{1+a^2} + c$$

$$= \frac{e^{ax} \sin x}{1+a^2} (a \sin x - \cos x) + c$$

$$\begin{aligned}
(9) C_a &= \frac{e^{ax}}{a} \cos^n x + \frac{n}{a} \int e^{ax} \cos^{n-1} x \sin x dx \\
&= \frac{e^{ax} \cos^n x}{a} + \frac{n}{a} \left[\frac{e^{ax} \cos^{n-1} x \sin x}{a} + \right. \\
&\quad \left. \frac{1}{a} \int e^{ax} \{(n-1) \cos^{n-2} x \sin^2 x - \cos^n x\} dx \right] \\
&= \frac{e^{ax} \cos^n x}{a} + \frac{n}{a^2} e^{ax} \cos^{n-1} x \sin x + \frac{n}{a^2} \int e^{ax} \{(n-1) \cos^{n-2} x - n \cos^n \\
&\quad x\} dx \\
&= \frac{e^{ax} \cos^n x}{a} + \frac{n}{a^2} e^{ax} \cos^{n-1} x \sin x + \frac{n(n-1)}{a^2} C_{n-2} - \frac{n^2}{a^2} C_n \\
\therefore C_a &= \frac{ae^{ax} \cos^n x}{n^2 + a^2} + \frac{ne^{ax} \cos^{n-1} x \sin x}{n^2 + a^2} + \frac{n(n-1)}{n^2 + a^2} C_{n-2}
\end{aligned}$$

$$(10) \text{ Put } a = 0 \text{ in the formula for } C_n. \therefore C_n = \int \cos^n x dx = \frac{\cos^{n-1} x \sin x}{n} + \frac{n-1}{n} \int \cos^{n-2} x dx$$

Which is the reduction formulas for $\int \cos^n x dx$

$$\begin{aligned}
(11) \int \sinh^n x dx &= \int \sinh^{n-1} x \sinh x dx = \sinh^{n-1} x \cosh x - (n-1) \int \sinh^{n-2} x \cosh^2 x dx \\
&= \sinh^{n-1} x \cosh x - (n-1) \int \sinh^{n-2} x (1 + \sinh^2 x) dx \\
&= \sinh^{n-1} x \cosh x - (n-1) I_{n-2} - n(n-1) I_n, \\
I_n &= \frac{\sinh^{n-1} x \cosh x}{n} - \frac{n-1}{n} I_{n-2}
\end{aligned}$$

$$\begin{aligned}
(12) I_n = \int \cosh^n x dx &= \int \cosh^{n-1} x \cosh x dx = \cosh^{n-1} x \sinh x - (n-1) \int \cosh^{n-2} x \sinh^2 x dx \\
&= \cosh^{n-1} x \sinh x - (n-1) \int \cosh^{n-2} x (\cosh^2 x - 1) dx = \cosh^{n-1} x \sinh x - \\
&\quad (n-1) I_n + (n-1) I_{n-2} \\
I_n &= \frac{\cosh^{n-1} x \sinh x}{n} + \frac{n-1}{n} I_{n-2}
\end{aligned}$$

2.8 Terminal Questions

1. Evaluate

$$i. \int_0^{\frac{\pi}{2}} \sin^4 x \cos^2 x dx$$

$$ii. \int_0^{\frac{\pi}{4}} \sin^4 \theta d\theta$$

iii. $\int_0^{\frac{\pi}{2}} \sin^5 x \cdot \cos^8 x dx$

iv. $\int_0^1 x^2(1 - x^2)^{\frac{3}{2}}. dx$ (put $x=\sin\theta$)

v. $\int_0^{2a} x^{\frac{9}{2}}(2a - x)^{\frac{3}{2}}. dx$ (put $x=2a \sin^2\theta$)

vi. If m & n are integers, prove that

$$\int_0^{\pi} \cos mx \cdot \sin nx dx = \frac{2n}{n^2-m^2} \text{ or } 0$$

according as $n-m$ is odd or even.

vii. $\int_0^a (a^2 + x^2)^{\frac{5}{2}}. dx.$

viii. $\int_0^{\pi} \frac{d\theta}{5+3\cos\theta}.$

ix. $\int \frac{dx}{1+\cos^2 x}$

x. $\int \frac{dx}{(5+4 \cos x)^2}$ (Hint: put $t = \tan \frac{x}{2}$ then \cos

$x = \frac{1-t^2}{1+t^2}$ & $\frac{dx}{dt} = \frac{2}{1+t^2}$)

RIL-146

UGMM-103/58

UNIT-3

INTEGRATION OF RATIONAL AND IRRATIONAL FUNCTIONS

Structure

- 3.1 Introduction
 - Objective
- 3.2 Integration of Rational Function
- 3.3 Some simple Rational Function
- 3.4 Partial Fraction Decomposition
- 3.5 Method of Substitution
- 3.6 Integration of Rational Trigonometric Functions
- 3.7 Integration of Irrational Functions
- 3.8 Summary
- 3.9 Terminal Questions

3.1 Introduction

In the previous unit we have come across various methods of integration. In this block, we will complete the discussion of methods of integration in this course. Here we shall deal with the integration of rational functions in detail.

Later on we shall consider some simple types of irrational functions. While going through this unit you will need to recall several standard forms like.

$$\int \frac{dx}{\sqrt{x^2 + a^2}} \cdot \int \sqrt{x^2 + a^2} dx \text{ etc,}$$

Objective:

After reading this unit you should be able to :

- Recognise proper and improper rational functions
- Integrate rational functions of a variable by using the method of partial fractions
- Integrate certain types of rational functions of $\sin x$ and $\cos x$

- Evaluate the integrals of some specified types of irrational functions
- Decide upon the method of integration to be used for integrating any given function.

3.2 Integration of Rational Functions

We know by now that it is easy to integrate any polynomial function, that is, a function f given by $f(x) = a_n x^n + a_{n-1} x + \dots + a_0$.

Definition 1: A function R is called a **rational function** if it is given by $R(x) = Q(x)/P(x)$, where $Q(x)$ and $P(x)$ are polynomials. It is defined for all x for which $P(x) \neq 0$.

If the degree of $Q(x)$ is less than the degree of $P(x)$, we say the $R(x)$ is a proper rational function. Otherwise, it is called an improper rational function, thus,

$$f(x) = \frac{x + 1}{x^2 + x + 2} \text{ is a proper rational function, and}$$

$$g(x) = \frac{x^3 + x + 5}{x - 2} \text{ is an improper one. But } g(x) \text{ can also be written as}$$

$$g(x) = (x^2 + 2x + 6) + \frac{17}{x - 2}$$

Here we have expressed $g(x)$, which is an improper rational function, as the sum of a polynomial and a proper rational function. This can be done for any improper rational function. Thus, we can always write

An improper rational function	=	A polynomial	+	A proper rational function
-------------------------------------	---	-----------------	---	----------------------------------

As we have already observed, a polynomial can be easily integrated. This means that the problem of integrating an improper rational function is reduced to that of integrating a proper rational function. Therefore, it is enough to study the techniques of integrating proper rational functions.

3.3 Some Simple Rational Function

Now we shall consider some simple types of proper rational functions, like $\frac{1}{x - a}$, $\frac{1}{(a - b)^k}$ and $\frac{x - m}{ax^2 + bx + c}$.

Example 1: The simplest proper rational function is of the type $\frac{1}{(x-a)}$.

We already know that $\int \frac{1}{(x-a)} dx = \ln |x-a| + c$

Example 2: Consider the function $f(x) = \frac{1}{(x+2)^4}$

To integrate this function we shall use the method of substitutions. Thus, if we put $u = x + 2$ $\frac{du}{dx} = 1$ and we can write

$$\int \frac{1}{(x+2)^4} dx = \int \frac{1}{u^4} du = \int u^{-4} du$$

$$= \frac{u^{-3}}{-3} + c = \frac{1}{3(x+2)^3} + c$$

Example 3: Consider the function $f(x) = \frac{2x+3}{3x^2-4x+5} + c$

Now $\int \frac{2x+3}{x^2-4x+5} dx$ can be written

$$\int \frac{2x-4}{x^2-4x+5} dx + \int \frac{7}{x^2-4x+5} dx$$

Thus, $\int \frac{2x-4}{x^2-4x+5} dx = \ln |x^2-4x+5| + c_1$

To evaluate the second integral on the right we write

$$\int \frac{1}{x^2-4x+5} dx = \int \frac{1}{(x^2-4x+4)+1} dx = \int \frac{1}{(x-2)^2+1} dx$$

Now, if we put $x-2 = u$, $\frac{du}{dx} = 1$ and

$$\int \frac{1}{x^2-4x+5} dx = \int \frac{1}{u^2+1} du = \tan^{-1} u + c_2 = \tan^{-1} (x-2) + c_2$$

This simplifies, $\int \frac{2x+3}{x^2-4x+5} dx = \ln |x^2-4x+5| + 7 \tan^{-1} (x-2) + c$

Check your progress

(1) Which of the following function are proper rational function? Write the improper ones as a sum of a polynomial and a proper rational function.

(a) $\frac{x^3 + 1}{x^4 + x}$ (b) $\frac{x^2 + x - 3}{x^2 + 1}$ (c) $\frac{x + 8}{x^2 + 5x + 8}$

(2) Evaluate:

(a) $\int \frac{dx}{2x + 3}$ (b) $\int \frac{dt}{(t + 5)^2}$

(c) $\int \frac{2x + 1}{x^2 + 8x + 1} dx$ (d) $\int \frac{4x + 1}{x^2 + x + 2} dx$

3.4 Partial Fraction Decomposition

In School you must have studied the factorisation of polynomials. For example, we know that $x^2 - 5x + 6 = (x - 2)(x - 3)$

Here $(x - 2)$ and $(x - 3)$ are two linear factors of $x^2 - 5x + 6$.

The polynomials like $x^2 + x + 1$, which cannot be factorised into real linear factors. Thus, it is not always possible to factorise a given polynomial into linear factors. But any polynomial can, in principle, be factored into linear and quadratic factors. We shall not prove this statement here. It is a consequence of the Fundamental theorem of Algebra. The actual factorization of a polynomial may not be very easy to carry out. But, whenever we can factorise the denominator of a proper rational function we can integrate it by employing the method of partial fractions.

Example4: Let us evaluate $\int \frac{5x - 1}{x^2 - 1} dx$. Here the integrand $\frac{5x - 1}{x^2 - 1}$ is a proper rational function. Its denominator $x^2 - 1$ can be factored into linear factors as:

$x^2 - 1 = (x - 1)(x + 1)$. This suggests that we can write the decomposition of $\frac{5x - 1}{x^2 - 1}$ into partial fractions as:

$$\frac{5x - 1}{x^2 - 1} = \frac{5x - 1}{(x - 1)(x + 1)} = \frac{A}{x - 1} + \frac{B}{x + 1}$$

If we multiply both sides by $(x - 1)(x + 1)$, we get

$$5x - 1 = A(x + 1) + B(x - 1). \text{ That is, } 5x - 1 = (A + B)x + A - B$$

By equating the coefficients of x we get $A + B = 5$

Equating the constant terms on both sides we get $A - B = -1$.

Solving these two equations in A and B we get $A = 2$ and $B = 3$

$$\text{Thus } \frac{5x - 1}{x^2 - 1} = \frac{2}{x - 1} + \frac{3}{x + 1}$$

Integrating both sides of this equations, we obtain,

$$\int \frac{5x - 1}{x^2 - 1} dx = \int \frac{2}{x - 1} dx + \int \frac{3}{x + 1} dx = 2 \ln |x - 1| + 3 \ln |x + 1| + c$$

The most important step in the evaluation of $\int \frac{5x - 1}{x^2 - 1} dx$ was the decomposition of the integrand into a partial fractions. The procedure for finding the values of the two unknowns A and B involved two simple simultaneous equations in two unknowns. But the higher the degree of the denominator, the more will be the number of unknowns, and it might be very tedious to find them.

In the equation $5x - 1 = A(x + 1) + B(x - 1)$, if we put $x = -1$, we get $-6 = -2B$, or $B = 3$. Similarly, if we put $x = 1$, we get $4 = 2A$ or $A = 2$.

Example 5: Suppose we want to integrate $\frac{2x^2 + x - 4}{x^3 - x^2 - 2x}$

We first observe that the denominator factors as $x(x + 1)(x - 2)$.

We first observe that the denominator factors as $x(x + 1)(x - 2)$

$$\text{This means we can write } \frac{2x^2 + x - 4}{x^3 - x^2 - 2x} = \frac{A}{x} + \frac{B}{x + 1} + \frac{C}{x - 2}$$

Multiplying by $x^3 - x^2 - 2x$ we get

$$2x^2 + x - 4 = (x + 1)(x - 2)A + Bx(x - 2) + Cx(x + 1)$$

Now, if we put $x = 0$ in this equations, we get $-4 = -2A$ or $A = 2$

Putting $x = -1$ gives $-3 = B$, or $B = -3$.

Putting $x = 2$, we get $6 = 6C$, or $C = 1$

$$\begin{aligned} \text{Thus, } \int \frac{2x^2 + x - 4}{x^3 - x^2 - 2x} dx &= -\int \frac{1}{x} dx - \int \frac{1}{x+1} dx + \int \frac{1}{x-2} dx \\ &= 2 \ln |x| - \ln |x+1| + \ln |x-2| + c. \end{aligned}$$

Example6: Take a look at the denominator of the integrand

$\int \frac{x}{x^3 - 3x + 2} dx$. In factors into $(x - 1)^2(x + 2)$. The linear factor $(x - 1)$ is repeated twice in the decomposition of $x^3 - 3x + 2$.

$$\text{In this case we write } \frac{x}{x^3 - 3x + 2} = \frac{A}{x + 2} + \frac{B}{x - 1} + \frac{C}{(x - 1)^2}$$

From this point we proceed as before to find A, B and C. We get

$$x = A(x - 1)^2 + B(x + 2)(x - 1) + C(x + 2)$$

We put $x = 1$ and $x = -2$ and get $C = 1/3$ and $A = -2/9$

Then to find B, let us put any other convenient value, say $x = 0$

$$\text{This gives us } 0 = A - 2B + 2C \text{ Or, } 0 = \frac{-2}{9} - 2B + \frac{2}{3}. \text{ This implies } B = \frac{2}{9}$$

$$\begin{aligned} \int \frac{x}{x^3 - 3x + 2} dx &= \frac{-2}{9} \int \frac{1}{x+2} dx + \frac{1}{3} \int \frac{1}{(x-1)^2} dx + \frac{1}{3} \int \frac{1}{(x-1)^2} dx \\ &= \frac{-2}{9} \ln |x+2| + \frac{2}{9} \ln |x-1| - \frac{1}{3} \left(\frac{1}{x-1} \right) + c \\ &= \frac{2}{9} \ln \left| \frac{x-1}{x+2} \right| - \frac{1}{3(x-1)} + c \end{aligned}$$

$$\text{Example 7: To evaluate } \int \frac{6x^3 - 11x^2 + 5x - 4}{x^4 - 2x^3 + x^2 - 2x} dx$$

We factorise $x^4 - 2x^3 + x^2 - 2x$ as $x(x - 2)(x^2 - 1)$. Then we write

$$\frac{6x^3 - 11x^2 + 5x - 4}{x^4 - 2x^3 + x^2 - 2x} = \frac{A}{x} + \frac{B}{x - 2} + \frac{Cx + D}{x^2 + 1}$$

$$\text{Thus, } 6x^3 - 11x^2 + 5x - 4 = A(x - 2)(x^2 + 1) + Bx(x^2 + 1) + (Cx + D)x(x - 2)$$

Next, we substitute $x = 0$ and $x = 2$ to get $A = 2$ and $B = 1$.

Then we substitute $x = 0$ and $x = 2$ to get $A = 2$ and $B = 1$.

Then we put $x = 1$ and $x = -1$ (some convenient values) to get $C = 3$ and $D = -1$

Thus

$$\begin{aligned} \int \frac{6x^3 - 11x^2 + 5x - 4}{x^4 - 2x^3 + x^2 - 2x} dx &= 2 \int \frac{1}{x} dx + \int \frac{1}{x-2} dx + \int \frac{3x-1}{x^2+1} dx \\ &= 2 \ln|x| + \ln|x-2| + \frac{3}{2} \int \frac{2x}{x^2+1} dx - \int \frac{dx}{x^2+1} \\ &= 2 \ln|x| + \ln|x-2| + \frac{3}{2} \ln|x^2+1| - \tan^{-1} x + c. \end{aligned}$$

Example 8: let us evaluate $\int \frac{x^3 + 2x}{x^2 - x - 2} dx$

Since the integrand is an improper rational function, we shall first write it as the sum of polynomial and a proper rational functions.

$$\text{Thus, } \frac{x^3 + 2x}{x^2 - x - 2} = x + 1 + \frac{5x + 2}{x^2 - x - 2}$$

$$\begin{aligned} \text{Therefore, } \int \frac{x^3 + 2x}{x^2 - x - 2} dx &= \int x dx + \int \frac{5x + 2}{x^2 - x - 2} dx \\ &= \frac{x^2}{2} + x + \int \frac{5x + 2}{x^2 - x - 2} dx \end{aligned}$$

Now let us decompose $\frac{5x + 2}{x^2 - x - 2}$ into partial fraction as

$$\frac{5x + 2}{x^2 - x - 2} = \frac{5x + 2}{(x-2)(x+1)} = \frac{A}{x-2} + \frac{B}{x+1}$$

$5x + 2 = A(x+1) + B(x-2)$ If $x = -1$, we get $-3 = -3 = -3B$, that is, $B=1$

If $x = +2$, we get $12 = +3A$, that is $A = 4$

$$\begin{aligned} \text{Therefore } \int \frac{5x + 2}{x^2 - x - 2} dx &= 4 \int \frac{dx}{x-2} + \int \frac{dx}{x+1} = 4 \ln|x-2| + \ln|x+1| + c \end{aligned}$$

$$\text{Hence } \int \frac{x^3 + 2x}{x^2 - x - 2} dx = \frac{x^2}{2} + x + 4 \ln|x-2| + \ln|x+1| + c$$

3.5 Method of Substitution

The method of partial fraction decomposition which we studied in the last sub section can be applied all rational functions. We can say this

because as we have mentioned earlier, the fundamental theorem of Algebra guarantees the factorization of any polynomial into linear and quadratic factors. But the actual process of factorizing a polynomial is sometimes not quite simple. In such cases it would be a good idea to critically examine the integrand to check if the method of substitution can be applied.

Example 9: Suppose we want to integrate $\frac{1}{x(x^5 + 1)}$ with respect to x .

$$\begin{aligned} \text{For this we write } x^5 = t. \quad \int \frac{x^4 dx}{x^5(x^5 + 1)} &= \frac{1}{5} \int \frac{dt}{t(t+1)} \\ &= \frac{1}{5} \int \left[\frac{1}{t} - \frac{1}{t+1} \right] dt = \frac{1}{5} \ln \left| \frac{t}{t+1} \right| + c = \frac{1}{5} \ln \left| \frac{x^5}{x^5 + 1} \right| + c \end{aligned}$$

Example 10; Let us integrate $\frac{x^2 - 1}{x^4 + x^2 + 1}$ w.r.t.x

$$\begin{aligned} \int \frac{x^2 - 1}{x^4 + x^2 + 1} dx &= \int \frac{(1 - 1/x^2)}{x^2 + 1 + 1/x^2} dx \quad (\text{division by } x^2) \\ &= \int \frac{(1 - 1/x^2)}{(x + 1/x)^2 - 1} dx &= \int \frac{dt}{t^2 - 1} \quad \text{if we put } t = x + \frac{1}{x} \\ &= \frac{1}{2} \int \left(\frac{1}{t-1} - \frac{1}{t+1} \right) dt = \frac{1}{2} \ln \left| \frac{t-1}{t+1} \right| + c = \frac{1}{2} \ln \left| \frac{x^2 - x + 1}{x^2 + x + 1} \right| + c \end{aligned}$$

Check your progress

(3) Evaluate: (a) $\int \frac{2}{x^2 + 2x} dx$ (b) $\int \frac{xdx}{x^2 - 2x - 3}$

(c) $\int \frac{3x - 13}{x^3 + 3x - 10}$

(d) $\int \frac{6x^2 + 22x - 23}{(2x - 1)(x^2 + x - 6)} dx$ (e) $\int \frac{3x^3}{x^2 + x - 2}$

(f) $\int \frac{x^2 + x - 1}{(x - 1)(x^2 - x + 1)} dx$ (g) $\int \frac{x^2 - 4x}{(x^2 + 1)^2} dx$

(4) Integrate the following function w.r.t.x.

(a) $\frac{x^2 - 1}{1 + x^4}$ (b) $\frac{1 + x^2}{1 + x^2 + x^4}$

3.6 Integration of Rational Trigonometric Functions

A polynomial in $\sin x$ and $\cos x$ is an expression of the form

$$p(\sin x, \cos x) = \sum_{n=0}^k \sum_{m=0}^p a_{m,n} \sin^m x \cos^n x, a_{m,n} \in \mathbb{R}.$$

The integratin of $f(\sin x, \cos x)$ can be carried out easily as we have already integrated $\sin^m x \cos^n x$. An expression, which is the ratio of two polynomials, $P(\sin x, \cos x)$ and $Q(\sin x, \cos x)$ is called a rational function of $\sin x$ and $\cos x$. In this section we shall discuss the integration of some simple rational functions in $\sin x$ and $\cos x$. We shall first indicate a general method for integrating these functions. Let $f(\sin x, \cos x)$ be a rational

function in $\sin x$ and $\cos x$. Thus, If $t = \tan \frac{x}{2}$ them $\frac{dt}{dx} = \frac{1}{2} \sec^2 \frac{x}{2} = \frac{1+t^2}{2}$. Since $\sin x =$

$$2 \sin \frac{x}{2} \cos \frac{x}{2} = \frac{2 \tan \frac{x}{2}}{\sec^2 \frac{x}{2}} = \frac{2t}{1+t^2}$$

$$\text{and } \cos x = \cos^2 \frac{x}{2} - \sin^2 \frac{x}{2} = \frac{1 - \tan^2 \frac{x}{2}}{\sec^2 \frac{x}{2}} = \frac{1-t^2}{1+t^2}$$

$$\text{we get, } \int f(\sin x, \cos x) dx = \int f\left(\frac{2t}{1+t^2}, \frac{1-t^2}{1+t^2}\right) \frac{2}{1+t^2} dt$$

$$= \int F(t) dt, \text{ Where } F(t) = f\left(\frac{2t}{1+t^2}, \frac{1-t^2}{1+t^2}\right) \frac{2}{1+t^2}$$

is a rational function of t . Now we can use the method of partial fraction decomposition to integrate $F(t)$. In principle then, we can integrate any rational function is $\sin x$ and $\cos x$.

Example 11 : Let us integrate $\frac{1}{a + b \cos x}$

$$\text{Now } a + b \cos x = a \left(\sin^2 \frac{x}{2} + \cos^2 \frac{x}{2} \right) + b \left(\cos^2 \frac{x}{2} - \sin^2 \frac{x}{2} \right)$$

$$= (a + b) \cos^2 \frac{x}{2} + (a - b) \sin^2 \frac{x}{2}$$

Therefore,
$$\int \frac{dx}{a + b + \cos x} = \int \frac{\sec^2 \frac{x}{2} dx}{(a + b) + (a - b) \tan^2 \frac{x}{2}}$$

$$\int \frac{\sec^2 \frac{x}{2} dx}{(a - b) + \left[\frac{a + b}{a - b} + \tan^2 \frac{x}{2} \right]}$$
. If we put $\tan \frac{x}{2} = t$, we get

$$\int \frac{dx}{a + b \cos x} = 2 \int \frac{dt}{(a - b) \left(\frac{a + b}{a - b} + t^2 \right)} = \frac{2}{a - b} \int \frac{dt}{\frac{a + b}{a - b} + t^2}$$

If $a > b > 0$, then $\frac{a + b}{a - b} > 0$, and we get

$$\begin{aligned} \int \frac{dx}{a + b \cos x} &= \frac{2}{\sqrt{a^2 - b^2}} \tan^{-1} \left(t \sqrt{\frac{a - b}{a + b}} \right) \\ &= \frac{2}{\sqrt{a^2 - b^2}} \tan^{-1} \left(t \sqrt{\frac{a - b}{a + b}} \right) = \frac{2}{\sqrt{a^2 - b^2}} \tan^{-1} \left(\sqrt{\frac{a - b}{a + b}} \tan \frac{x}{2} \right) \end{aligned}$$

If $0 < a < b$, then $\frac{a + b}{a - b} < 0$, and

$$\begin{aligned} \int \frac{dx}{a + b \cos x} &= \frac{2}{\sqrt{b^2 - a^2}} \ln \frac{\sqrt{b + a} + \sqrt{b - a} \tan \frac{x}{2}}{\sqrt{b + a} - \sqrt{b - a} \tan \frac{x}{2}} \\ &= \frac{1}{\sqrt{b^2 - a^2}} \ln \frac{\sqrt{b + a} + \sqrt{b - a} \tan \frac{x}{2}}{\sqrt{b + a} - \sqrt{b - a} \tan \frac{x}{2}} \end{aligned}$$

Example 12 : To evaluate $\int \frac{1 + \sin x}{\sin x(1 + \cos x)} dx$, we write

$$\int \frac{1 + \sin x}{\sin x(1 + \cos x)} dx = \int \frac{dx}{\sin x(1 + \cos x)} + \int \frac{dx}{1 + \cos x}$$

$$= \frac{1}{4} \int \frac{\sec^4 \frac{x}{2}}{\tan \frac{x}{2}} dx + \frac{1}{2} \int \sec^2 \frac{x}{2} dx = \frac{1}{2} \int \frac{1+t^2}{t} dt + \int dt \quad (\tan \frac{x}{2} = t)$$

$$= \frac{1}{2} \left[\int \frac{1}{t} dt + \int t dt \right] + \int dt = \frac{1}{2} \left[\ln |t| + \frac{t^2}{2} \right] + t + c$$

$$\text{Thus, } \int \frac{1 + \sin x}{\sin x(1 + \cos x)} dx = \frac{1}{2} \ln |\tan x / 2| + \frac{1}{4} \tan^2 \frac{x}{2} + \tan \frac{x}{2} + c$$

$$\int \frac{\sin x \cos x}{1 + \sin^2 x} = 4 \int \frac{t(1-t^2)dt}{(1+t^2)(1+6t^2+t^4)} dt \quad (\text{put } \tan \frac{x}{2} = t)$$

$$\text{Not } 1+6t^2+t^4 = (2+\sqrt{8}+t^2)(3-\sqrt{8}+t^2)$$

In $\int \frac{\sin x \cos x}{1 + \sin^2 x} dx$, if we make the substitution $1 + \sin^2 x = t$, we get

$$\int \frac{\sin x \cos x dx}{1 + \sin^2 x} = \frac{1}{2} \int \frac{dt}{t} = \frac{1}{2} \ln |t| + c = \frac{1}{2} \ln(1 + \sin^2 x) + c.$$

3.7 Integration of Irrational Functions

The task of integrating functions gets tougher if the given function is an irrational one, that is, it is not of the form $\frac{Q(x)}{P(x)}$. In this section we

shall give you some tips for evaluating some particular types of irrational functions. In most cases our endeavour will be to arrive at a rational function through an appropriate substitution. This rational function can then be easily evaluated.

(I) Integration of functions containing only fractional powers of x:

In this case we put $x = t^n$, when n is the lowest common multiple (l.c.m.) of the denominators of powers of x . This substitution reduces the function to a rational function of t .

Example 13: Let us evaluate $\int \frac{2x^{1/2} + 3x^{1/3}}{1 + x^{1/2}} dx$.

We put $x = t^6$, as 6 is the l.c.m. of 2 and 3. We get

$$\int \frac{2x^{1/2} + 3x^{1/3}}{1 + x^{1/2}} dx = 6 \int \frac{2t^3 + 3t^2}{1 + t^2} t^5 dt$$

$$\begin{aligned}
&= 6 \int \frac{2t^8 + 3t^7}{1+t^2} dt = 6 \int \left[2t^6 + 3t^5 - 2t^4 - 3t^3 + 2t^2 + 3t - 2 - \frac{3t-2}{1+t^2} \right] dt \\
&= 6 \left[\frac{2}{7}t^7 + \frac{1}{2}t^6 - \frac{2}{5}t^5 - \frac{3}{4}t^4 + \frac{2}{3}t^3 + \frac{3}{2}t^2 - 2t - \frac{3}{2}\ln(1+t^2) + 2 \tan^{-1} t \right] + c \\
&= \frac{12}{7}x^{7/6} + 3x - \frac{12}{5}x^{5/6} - \frac{9}{2}x^{2/3} + 4x^{1/2} + 9x^{1/3} - 12x^{1/6} - 9 \ln |1+x^{1/3}| \\
&\quad + 12 \tan^{-1} x^{1/6} + c
\end{aligned}$$

(II) Integral of the type $\int \frac{dx}{\sqrt{ax^2 + bx + c}}$

Here we shall have to consider two case (i) $a > 0$ and (ii) $a < 0$.

In each case we will try to put the given integrand in a form which we have already seen have to integrate.

$$(i) a > 0 \int \frac{dx}{\sqrt{ax^2 + bx + c}} + \frac{1}{\sqrt{a}} \int \frac{dx}{\sqrt{x^2 + bx/a + c/a}} = \frac{1}{\sqrt{a}} \int \frac{dx}{\sqrt{(a+b/2a)^2 + c/a - b^2/4a^2}}$$

If we put $t = x + b/2a$, we get

$$\int \frac{dx}{\sqrt{ax^2 + bx + c}} = \frac{1}{\sqrt{a}} \int \frac{dt}{\sqrt{t^2 + (c/a - b^2/4a^2)}}$$

(ii) $a < 0$; If we put $-a = d$, then $d > 0$, and we can write

$$\begin{aligned}
\int \frac{dx}{\sqrt{a^2 + bx + c}} &= \frac{1}{\sqrt{d}} \int \frac{dx}{\sqrt{(c/d + b^2/4d^2) - (x - b/d)^2}} \\
&= \frac{1}{\sqrt{d}} \int \frac{dt}{\sqrt{(c/d + b^2/4d^2) - t^2}}, \text{ if } t = x - b/2d
\end{aligned}$$

(III) Integration of $\frac{1}{(fx + e)\sqrt{ax^2 + bx + c}} dx$.

Example 14: Suppose we want to evaluate $\int \frac{dx}{(x+1)\sqrt{x^2+4x+2}}$

. Let us put

$x = 1/y$. Then $\frac{-1}{y^2} \frac{dy}{dx} = 1$. Now we will try to express $x^2 + 4x + 2$ in terms of y . For this we write $x^2 + 4x + 2 = (x + 1)^2 + 2(x + 1) - 1 = \frac{1}{y^2} + \frac{2}{y} - 1 = \frac{1 + 2y - y^2}{y^2}$. Therefore

$$\int \frac{dx}{(x+1)\sqrt{x^2+4x+2}} = \int \frac{-\frac{1}{y^2} dy}{\frac{1}{y} \sqrt{\frac{1+2y-y^2}{y^2}}} = -\int \frac{dy}{\sqrt{1+2y-y^2}}$$

$$= -\int \frac{dy}{\sqrt{2-(y-1)^2}} = \cos^{-1}\left(\frac{y-1}{\sqrt{2}}\right) = \cos^{-1}\left[\frac{-x}{(x+1)\sqrt{2}}\right] + c$$

This example suggests that in integrating $\frac{1}{(fx + e)\sqrt{ax^2 + bx + c}}$, we should make the substitution $fx + c = \frac{1}{y}$, and then simplify the expression.

(IV) integration of $\frac{(Ax + b)}{\sqrt{ax^2 + bx + c}}$

We break $Ax + B$ into two parts such that the first part is a constant multiple of the differential coefficient of $ax^2 + bx + c$, that is, $2ax + b$, and the second part is independent of x . thus,

$$Ax + B = \frac{A}{2a}(2ax + b) + B - \frac{Ab}{2a} \text{ and}$$

$$\int \frac{(Ax + B)dx}{\sqrt{ax^2 + bx + c}} = \frac{A}{2a} \int \frac{(2ax + b)dx}{\sqrt{ax^2 + bx + c}} + \frac{(2aB - Ab)}{2a} \int \frac{dx}{\sqrt{ax^2 + bx + c}}$$

$$= \frac{A}{a} \sqrt{ax^2 + bx + c} + \frac{(2aB - Ab)}{2a} \int \frac{dx}{\sqrt{ax^2 + bx + c}}$$

(v) integration of $(Ax + B) \sqrt{ax^2 + bx + c}$

$$\int (Ax + B)\sqrt{ax^2 + bx + c} dx = \frac{A}{2a} \int (2ax + b)\sqrt{ax^2 + bx + c} dx +$$

$$\begin{aligned} & \frac{B2a - Ab}{2a} \int \sqrt{ax^2 + bx + c} dx \\ &= \frac{A}{3a} (ax^2 + bx + c)^{3/2} + \frac{2aB - Ab}{2a} \int \sqrt{ax^2 + bx + c} dx. \end{aligned}$$

Example 15: To evaluate $\int \frac{x+2}{\sqrt{x^2+2x+3}} dx$.

We note that $x+2 = \frac{1}{2}(2x+2) + 1$

and write $\int \frac{(x+2)dx}{\sqrt{x^2+2x+3}} = 1/2 \int \frac{(2x+2)dx}{\sqrt{x^2+2x+3}} + \int \frac{dx}{\sqrt{x^2+2x+3}}$

$$\begin{aligned} &= \sqrt{x^2+2x+3} + \int \frac{dx}{\sqrt{x^2+2x+3}} \\ &= \sqrt{x^2+2x+3} + \sinh^{-1}\left(\frac{x+1}{\sqrt{2}}\right) + c \end{aligned}$$

$$\frac{1}{\sqrt{x^2+2x+3}} = \frac{1}{\sqrt{(x+1)^2+2}}$$

Example 16: To evaluate $\int \frac{x^2+2x+3}{\sqrt{x^2+x+1}} dx$

we note that $x^2+2x+3 = x^2+x+1 + x+2 = x^2+x+1 + \frac{1}{2}(2x+1) + \frac{3}{2}$

hence $\int \frac{(x^2+2x+3)}{\sqrt{x^2+x+1}} dx = \int \sqrt{x^2+x+1} dx + \frac{1}{2} \int \frac{(2x+1)}{\sqrt{x^2+x+1}} dx$

$$+ \frac{3}{2} \int \frac{dx}{\sqrt{(x+\frac{1}{2})^2 + \frac{3}{4}}} = \int \sqrt{(x+\frac{1}{2})^2 + \frac{3}{4}} dx + \sqrt{x^2+x+1} dx$$

$$+ \frac{3}{2} \ln \frac{2}{\sqrt{3}} \left(x + \frac{1}{2} + \sqrt{x^2+x+1}\right) + c$$

$$= \frac{(x+\frac{1}{2})}{2} \sqrt{x^2+x+1} + \frac{3}{8} \ln \frac{2}{\sqrt{3}} \left(x + \frac{1}{2} + \sqrt{x^2+x+1}\right)$$

$$\begin{aligned}
& + \sqrt{x^2 + x + 1} + \frac{3}{2} \ln \frac{2}{\sqrt{3}} \left(x + \frac{1}{2} + \sqrt{x^2 + x + 1} \right) + c \\
& = \frac{1}{4} (2x + 5) \sqrt{x^2 + x + 1} + \frac{15}{8} \ln \frac{2}{\sqrt{3}} \left(x + \frac{1}{2} + \sqrt{x^2 + x + 1} \right) + c
\end{aligned}$$

Check your progress

(5) Evaluate $\int \frac{dx}{a + b \sin x}$

(6) Integrate (a) $\frac{1}{4 + 5 \cos x}$ (b) $\frac{\cos x}{2 - \cos x}$ w.r.t.x.

(7) Integrate the following (a) $\frac{\sqrt{x}}{1 + \sqrt[4]{x}}$ (b)

$$\frac{1}{(2-x)\sqrt{1-2x+3x^2}}$$

3.8 Summary

In this unit we have covered the following points:

1. A rational function f of x is given by $f(x) = P(x)/Q(x)$, where $P(X)$ and $Q(x)$ are polynomials called improper.
2. A proper rational expression can be resolved into partial fractions with linear or quadratic denominators.
3. A rational function can be integrated by the metho of partial fractions.
4. Integration of rational function of $\sin x$ and $\cos x$ can be done b putting $t = \tan \frac{x}{2}$.
5. Integration of irrational function of the following types is discussed.

(i) $\frac{1}{\sqrt{ax^2 + bx + c}}$

(ii) $\frac{1}{(fx + e)\sqrt{ax^2 + bx + c}}$

(iii) $\frac{Ax + B}{\sqrt{ax^2 + bx + c}}$

(v) $(Ax + B)\sqrt{ax^2 + bx + c}$

A check list of points to be considered while evaluating any integral is given.

Note: When we are faced with a new integrand, the following suggestions are required:

Check the integrand to see if it fits one of the patterns

$$\int u^n du \text{ or } \int \frac{du}{u}$$

- (1) See if the integrand fits any one of the patterns obtained by the reversal of differentiation formulas (We have considered these in Unit 3)
- (2) If none of these patterns is appropriate, and if the integrand is a rational function, then our theory of partial fraction enables us to integrate it.
- (3) If the integrand is a rational function of $\sin x$ and $\cos x$, and simpler methods of previous units fail, the substitution $t = \tan \frac{x}{2}$ will make the integrand into a rational function of t , which can then be evaluated.
- (4) If the integrand is a radical of one of the form $\sqrt{a^2 - x^2}$, $\sqrt{a^2 + x^2}$, $\sqrt{x^2 - a^2}$. then the trigonometric substitution $x = a \sin \theta$, $x = a \cos \theta$ or $x = a \sec \theta$ will reduce the integrand to a rational function of $\sin \theta$ and $\cos \theta$. If the radical is of the form $\sqrt{ax^2 + bx + c}$ as square completion $\sqrt{a(x + b/2a)^2 + c - b^2/4a}$ will reduce it essentially to one of the above radicals.
- (5) If the integrand is an irrational function of x , try to express it as a rational function or an integrable radical through appropriate substitution.
- (6) Inspect the integrand to see if it will yield to integration by parts.

Finally we would like to remind you again that a log of practice is essential if you want to master the various techniques of integration. We have already mentioned that a proper choice of the method of integration is the key to the correct evaluation of any integral. Now let us briefly recall what we have covered in this limit.

Solution and Answers of check your progress

(1) (a) and (c) are proper (b) $\frac{x^2 + x - 3}{x^2 + 1} = 1 + \frac{x - 4}{x^2 + 1}$

(d) $\frac{x^4 + x^3 - 5}{x - 2} = x^3 + 3x^2 + 6x^2 + 12 + \frac{19}{x - 2}$

(2) (a) $\int \frac{dx}{2x - 3} = \frac{1}{2} \int \frac{2dx}{2x - 3} = \frac{1}{2} \ln |2x - 3| + c$ (b)

$\int \frac{dt}{(t + 5)^2} = \frac{-1}{t + 5} + c$

(c) $\int \frac{2x + 1}{x^2 + 8x + 1} dx = \int \frac{2x + 8}{x^2 + 8x + 1} dx - 7 \int \frac{dx}{x^2 + 8x + 1}$

$= \ln |x^2 + 8x + 1| - 7 \int \frac{dx}{(x + 4)^2 - 15} = \ln |x^2 + 8x + 1| - 7 \int \frac{du}{u^2 - 15},$

if $u = x + 4$

$= \ln |x^2 + 8x + 1| - \frac{7}{2\sqrt{15}} \ln \left| \frac{u - \sqrt{15}}{u + \sqrt{15}} \right| + c = \ln |x^2 + 8x + 1| -$

$\frac{7}{2\sqrt{15}} \ln \left| \frac{x + 4 - \sqrt{15}}{x + 4 + \sqrt{15}} \right| + c$

(d) $\int \frac{4x + 1}{x^2 + x + 2} dx = \int \frac{2(2x + 1) - 1}{x^2 + x + 2} dx$

$= 2 \int \frac{2x + 1}{x^2 + x + 2} dx - \int \frac{dx}{x^2 + x + 1}$

$= 2 \ln |x^2 + x + 2| - \int \frac{dx}{\left(x + \frac{1}{2}\right)^2 + \frac{7}{4}} = 2 \ln |x^2 + x + 2| -$

$\frac{2}{\sqrt{7}} \tan^{-1} \left(\frac{x + 1/2}{\sqrt{7}/2} \right) + c$

$= 2 \ln |x^2 + x + 2| - \frac{2}{\sqrt{7}} \tan^{-1} \left(\frac{2x + 1}{\sqrt{7}} \right) + c$

(3) (a) $\frac{2}{x^2 + 2x} = \frac{2}{x(x + 2)} = \frac{A}{x} + \frac{B}{x + 2} \Rightarrow 2 = A(x + 2) + Bx$

$$x = 0 \Rightarrow 2 = 2A \Rightarrow A = 1, x = -2 \Rightarrow -2 = -2B \Rightarrow B = -1$$

$$\therefore \frac{2}{x^2 + 2x} = \frac{1}{x} - \frac{1}{x+2} \therefore \int \frac{2}{x^2 + 2x} dx = \int \frac{1}{x} dx - \int \frac{1}{x+2} dx$$

$$= \ln |x| - \ln |x+2| + c = \ln \left| \frac{x}{x+2} \right| + c$$

$$(b) \frac{x}{x^2 - 2x + 3} = \frac{x}{(x-3)(x+1)} = \frac{A}{x-3} + \frac{B}{x+1}$$

$$x = A(x+1) + B(x-3), x = 3 \Rightarrow 3 = 4A \Rightarrow A = \frac{3}{4}$$

$$x = -1 \Rightarrow -1 = -4B \Rightarrow B = \frac{1}{4}$$

$$\therefore \int \frac{x}{x^2 - 2x - 3} dx = \int \frac{3x}{4(x-3)} + \int \frac{dx}{4(x+1)} =$$

$$\frac{3}{4} \ln |x-3| + \frac{1}{4} \ln |x+1| + c$$

$$(c) \frac{3x-13}{x^2 + 3x - 10} = \frac{3x-13}{(x+5)(x-2)} = \frac{A}{x+5} + \frac{B}{x-2}$$

$$\therefore 3x - 13 = A(x-2) + B(x+5)$$

$$x = 2 \Rightarrow -7 = 7B \Rightarrow B = -1, x = -5 \Rightarrow -28 = -7A \Rightarrow A = -1$$

$$\Rightarrow \int \frac{3x-13}{x^2 + 3x - 10} dx = 4 \int \frac{dx}{x+5} - \int \frac{dx}{x-2}$$

$$\Rightarrow \int \frac{3x-13}{x^2 + 3x - 10} dx = 4 \int \frac{dx}{x+5} - \int \frac{dx}{x-2} = 4 \ln |x+5| - \ln |x-2| +$$

c

(d)

$$\frac{6x^2 + 22x - 23}{(2x-1)(x^2 + x - 6)} = \frac{6x^2 + 22x - 23}{(2x-1)(x+3)(x-2)} = \frac{A}{2x-1} + \frac{B}{x+3} + \frac{C}{x-2}$$

$$6x^2 + 22x - 23 = A(x+3)(x-2) + B(2x-1)(x-2) + C(2x-1)(x+3)$$

$$x = 2 \Rightarrow 45 - 15C \Rightarrow C = 3, x = -3 \Rightarrow -35 = 35B \Rightarrow B = -1$$

$$x = \frac{1}{2} \Rightarrow \frac{-21}{2} = \frac{-21}{4} A \Rightarrow A = 2$$

$$\therefore \int \frac{6x^2 + 22x - 23}{(2x-1)x^2 + x - 6} dx = \frac{1}{2} \ln|2x-1| - \ln|x+3| + 3\ln|x-1| + C$$

$$(e) \frac{3x^2}{x^2 + x - 2} = 3x - 3 + \frac{9x - 6}{x^2 + x - 2}$$

$$\therefore \int \frac{3x^2}{x^2 + x - 2} dx = \int (3x - 3) dx + 3 \int \frac{3x - 2}{x^2 + x - 2} dx = \frac{3x^2}{2} - 3x + 8\ln|x+2| + \ln|x-1| + c$$

$$(f) \frac{x^2 + x - 1}{(x-1)(x^2 - x + 1)} = \frac{A}{x-1} + \frac{Bx + c}{x^2 - x + 1}$$

$$\therefore x^2 + x - 1 = A(x^2 - x + 1) + (Bx + c)(x - 1). \quad x = 1 \Rightarrow 1 = A$$

we have $x^2 + x - 1 = x^2 - x + 1 + Bx^2 + (C - B)x - C$ thus $-1 = 1 - C \therefore C = 2$

$$\therefore \int \frac{x^2 + x - 1}{(x-1)(x^2 - x + 1)} dx = \int \frac{dx}{x-1} + 2 \int \frac{dx}{x^2 - x + 1} = \ln|x-1| + \frac{4}{\sqrt{3}} \tan^{-1} \frac{2x-1}{\sqrt{3}} + c$$

$$(g) \frac{x^3 - 4x}{(x^2 + 1)^2} = \frac{Ax + B}{x^2 + 1} + \frac{Cx + D}{(x^2 + 1)^2}$$

$$\therefore x^3 - 4x = (Ax + B)(x^2 + 1) + (Cx + D)$$

$$\therefore x^3 - 4x = Ax^3 + Bx^2 + (A+C)x + (B+D) \quad \therefore A = 1, B = 0, C = -5, D = 0$$

$$\therefore \int \frac{x^3 - 4x}{(x^2 + 1)^2} dx = \int \frac{x}{x^2 + 1} dx - 5 \int \frac{x}{(x^2 + 1)^2} dx$$

$$= \frac{1}{2} \ln(x^2 + 1) + \frac{5}{2} \frac{1}{x^2 + 1} + c$$

$$(4) (a) \int \frac{x^2 - 1}{1 + x^4} dx = \int \frac{1 - \frac{1}{x^2}}{\frac{1}{x^2} + x^2} dx = \int \frac{1 - \frac{1}{x^2}}{\left(x + \frac{1}{x}\right)^2 - 2} dx$$

$$= \int \frac{dt}{t^2 - 2} \text{ if } t = x + \frac{1}{x} = \frac{1}{2\sqrt{2}} \ln \left| \frac{x + \frac{1}{x} - \sqrt{2}}{x + \frac{1}{x} + \sqrt{2}} \right| + c$$

$$(b) \int \frac{1+x^2}{1+x^2+x^4} dx = \int \frac{x^{\frac{1}{2}+1}}{x^{\frac{1}{2}}1+x^2} dx = \int \frac{x^{\frac{1}{2}+1}}{(x-\frac{1}{x})^2+3} dx$$

$$= \int \frac{dt}{t^2+3}, \text{ if } t = x - \frac{1}{x}, \frac{dt}{dx} = 1 + \frac{1}{x^2}$$

$$= \frac{1}{\sqrt{3}} \tan^{-1} \left\{ \frac{1}{\sqrt{3}} \left(x - \frac{1}{x} \right) \right\} + c = \frac{1}{3} \tan^{-1} \left(\frac{x^2-1}{\sqrt{3}x} \right) + c$$

$$(5) \int \frac{dx}{a+b \sin x} = \int \frac{2dt}{a(1+t^2)+2bt}, \text{ if } t = \tan x/2$$

$$= 2 \int \frac{2dt}{at^2+2bt+a} = 2 \int \frac{dt}{(\sqrt{at} + \frac{b}{\sqrt{a}})^2 + (\frac{a^2-b^2}{a})}$$

$$= \frac{2}{\sqrt{a^2-b^2}} \tan^{-1} \left(\frac{at+b}{\sqrt{a^2-b^2}} \right) + c$$

$$= \frac{2}{\sqrt{a^2-b^2}} \tan^{-1} \left(\frac{a \tan \frac{x}{2} + c}{\sqrt{a^2-b^2}} \right) + c$$

$$(6) (a) \int \frac{dx}{4+6 \cos x} = 2 \int \frac{dt}{\left\{ 4+5 \left(\frac{1-t^2}{1+t^2} \right) \right\} (1+t^2)}$$

$$= 2 \int \frac{dt}{4+4t^2+5-5t^2} = 2 \int \frac{dt}{9-t^2} = \frac{1}{3} \ln \left| \frac{3+t}{3-t} \right| + c$$

$$(b) \int \frac{\cos x}{2-\cos x} dx = 2 \int \frac{\left(\frac{1-t^2}{1+t^2} \right) dt}{\left\{ 2 \left(\frac{1-t^2}{1+t^2} \right) \right\} (1+t^2)}$$

$$= 2 \int \frac{1-t^2}{2(1+t^2)^2-1+t^2} dt = 2 \int \frac{1-t^2}{(t^2+1)(3t^2+1)} dx$$

$$\text{If we write } \frac{1-t^2}{(t^2+1)(3t^2+1)} = \frac{At+B}{t^2+1} + \frac{Ct+D}{3t^2+1},$$

$$\text{then } 1 - t^2 = 9At + B(3t^2 + 1) + (Ct + D)(t^2 + 1)$$

$$\therefore 1 = B + D, \quad 0 = A + C, \quad -1 = 3B + D, \quad 0 = 3A + C \quad \therefore A = C = 0, B = -1, D = 2$$

$$= -2 \int \frac{dt}{t^2 + 1} + 4 \int \frac{dt}{3t^2 + 1} = -2 \tan^{-1}(t) + \frac{4}{\sqrt{3}} \tan^{-1}(\sqrt{3}t) + c$$

$$= -2 \frac{x}{2} + \frac{4}{\sqrt{3}} \tan^{-1}(\sqrt{3} \tan \frac{x}{2}) + c$$

$$= -x + \frac{4}{\sqrt{3}} \tan^{-1}(\sqrt{3} \tan \frac{x}{2}) + c$$

$$(7) (a) \int \frac{\sqrt{x}}{1 + \sqrt[4]{x}} dx = \int \frac{t^2}{1+t} 4t dt \text{ if } t = \sqrt[4]{x} = 4 \int \frac{t^5}{1+t} dt$$

$$= 4 \int \left[t^4 - t^3 + t^2 - t + -\frac{1}{t+1} \right] dt$$

$$= 4 \left[\frac{t^5}{5} - \frac{t^4}{4} + \frac{t^3}{3} - \frac{t^2}{2} + t - \ln |t+1| \right] + c$$

$$= 4 \left[\frac{x^{5/4}}{5} - \frac{x}{4} + \frac{x^{3/4}}{3} - \frac{x^{1/2}}{2} + x^{1/4} - \ln |x^{1/4} + 1| \right] + c$$

$$(b) \int \frac{dx}{(2x-x)\sqrt{1-2x+3x^2}} \text{ put } 2-x = \frac{1}{t}. \text{ Then } \frac{dx}{dt} = \frac{1}{t^2}$$

$$\int \frac{dx}{(3-x)\sqrt{1-2x+3x^2}} = \int \frac{dx}{(2-x)\sqrt{3(2-x)^2 - 10(2-x) + 9}}$$

$$= \int \frac{t}{\sqrt{\frac{3}{t^2} - \frac{10}{t} + 9}} \frac{1}{t^2} dt$$

$$= \int \frac{t}{\sqrt{9t^2 - 10t + 3}} = \int \frac{dt}{\sqrt{(3t - \frac{5}{3} + \frac{2}{9})}}$$

$$= \frac{1}{3} \int \frac{dt}{\sqrt{(t - \frac{5}{9})^2 (\frac{\sqrt{2}}{9})^2}} = \frac{1}{3} \sinh^{-1} \left(\frac{t - 5/9}{\sqrt{2}/9} \right) + c$$

$$= \frac{1}{3} \sin^{-1} \frac{9}{\sqrt{2}} \left(\frac{1}{2-x} - \frac{5}{9} \right) + c = \frac{1}{3} \sin^{-1} \left(\frac{5x-1}{\sqrt{2}(2-x)} \right) + c$$

3.9 Terminal Questions

1. Evaluate

i. $\int \frac{x dx}{(x-1)^2(x+2)}$

ii. $\int \frac{dx}{x(x+1)^2}$

iii. $\int_0^1 \frac{dx}{1-x+x^2}$

iv. $\int \frac{(x+2)}{(2x^2+4x+8)^2} dx$

v. $\int \frac{1}{x(x^4+1)} dx$

vi. $\int \frac{dx}{(x^2+3)^3}$

vii. $\int \frac{x dx}{(x-3)\sqrt{x+1}}$

viii. $\int \frac{1+x^{\frac{1}{2}}}{1+x^{\frac{1}{3}}} dx$

ix. $\int \frac{dx}{(x-1)\sqrt{x^2+x+1}}$ (put $x-1=\frac{1}{t}$)

x. $\int \frac{dx}{(x^2+1)\sqrt{x^2-1}}$ (put $x-1=\frac{l}{t}$)

UNIT-4

TANGENT AND NORMAL OF THE CURVES

Structure

- 4.1 Introduction
 - Objectives
- 4.2 Equations of tangents and normal
 - 4.2.1 Equation of a Tangent Line
 - 4.2.2 Equation of a Normal Line
 - 4.2.3 Vertical Tangents
- 4.3 Angles of intersection of two curves
- 4.4 Polar Coordinate System
 - 4.4.1 Transformations between Polar and Rectangular Coordinates
- 4.5 Tangents at the origin
- 4.6 Summary
- 4.7 Terminal Questions

4.1 Introduction

In this unit, our aim is to re-acquaint with some essential elements of two dimensional geometry. The French philosopher mathematician **Rene Descartes** (1596--1650) was the first to realize that geometrical ideas can be translated into algebraic relations. The combination of Algebra and Plane Geometry came to be known as **Coordinate Geometry** or **Analytical Geometry**. A basic necessity for the study of Coordinate Geometry is thus, the introduction of a coordinate system and to define coordinates in the concerned space. We will briefly touch upon the distance formula and various ways of representing a straight line algebraically. Then we shall look at the polar representation of a point in the plane. Next, we will talk about symmetry with respect to origin or a coordinate axis. Finally, we shall consider some ways in which a coordinate system can be transformed. This collection of topics may seem random to us .

Objectives:

After studying this section, the students should be able to

- Determine the equations of tangent, normal and angle between the curves
- Locate the tangent at the origin and singular points of the given equation of the curve.
- Determine the asymptotes parallel to X-axis, Y-axis and oblique asymptotes.
- Draw the curve for the equation by using these properties.
- Relate the polar coordinates and cartesian coordinates of a point.
- Obtain the polar form of an equation.

4.2 Equations of tangent and normal

In this section we study, how differentiation can be used to calculate the equations of tangent and normal to the curve.

‘The tangent is a straight line which just touches the curve at a given point without intersecting it’. If the curve is of second degree.

‘The normal is a straight line which is perpendicular to the tangent at the point of tangency’.

To calculate the equations of tangent and normal lines, we make use of the fact that equation of a straight line passing through the point with coordinates (x_1, y_1) or $(a, f(a))$ having the slope (or gradient) given by $m = \frac{dy}{dx}$ or $f'(a)$ at the point $x = a$. Where $f'(a)$ is the instantaneous rate of change at that point.

4.2.1 Equation of a Tangent Line

It is given by $\frac{y - y_1}{x - x_1} = m$ Or $(y - y_1) = m(x - x_1)$.

Equivalently,

$$\frac{f(x) - f(a)}{x - a} = f'(a) \text{ Or } f(x) - f(a) = f'(a)(x - a)$$

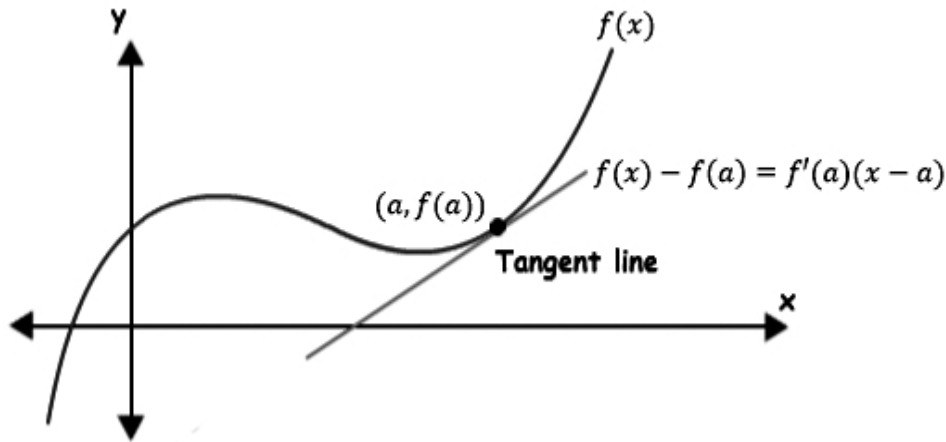

4.2.2 Equation of a Normal Line

We can find the equation of the normal line at the point $x = a$ by taking the negative inverse of the slope of the tangent line. If the slope (or gradient) of the tangent is $m = \frac{dy}{dx}$ or $f'(a)$ at the point $x = a$. The

negative inverse is $-\frac{1}{m} = -\frac{dx}{dy}$ or $-\frac{1}{dy/dx}$ or $\frac{-1}{f'(a)}$.

As such the equation of the normal line is given by

It is given by $\frac{y - y_1}{x - x_1} = \frac{-1}{m}$ Or $(y - y_1) = \frac{-1}{m}(x - x_1)$.

Equivalently,

$$\frac{f(x) - f(a)}{x - a} = \frac{-1}{f'(a)} \text{ Or } f(x) - f(a) = \frac{-1}{f'(a)}(x - a)$$

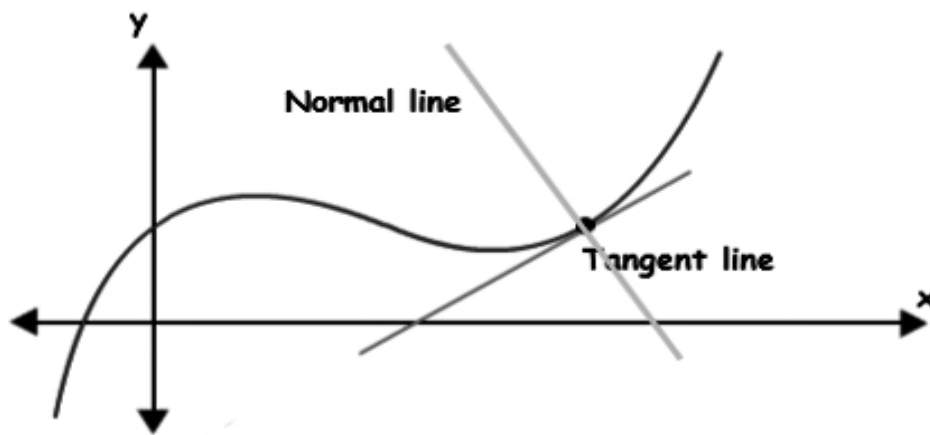

Example 1: Find the equations of tangent and normal lines to the curve given by the equation $y = \sqrt{2x - 1}$ at $(5, 3)$.

Solution: We have $y = \sqrt{2x-1}$

$$\begin{aligned}\therefore \frac{dy}{dx} &= \frac{1}{2\sqrt{2x-1}} \cdot (2) = \frac{1}{\sqrt{2x-1}} \\ \left(\frac{dy}{dx}\right)_{x=5} &= \frac{1}{\sqrt{2(5)-1}} = \frac{1}{3} = \text{Slope}\end{aligned}$$

Now, Equation of the tangent line is given by

$$\begin{aligned}(y - y_1) &= m(x - x_1) \\ \therefore (y - 3) &= \frac{1}{3}(x - 5) \quad \text{Or} \quad x - 3y + 4 = 0\end{aligned}$$

And equation of the normal line is given by

$$\begin{aligned}(y - y_1) &= \frac{-1}{m}(x - x_1) \\ \therefore (y - 3) &= -3(x - 5) \quad \text{Or} \quad 3x + y - 12 = 0\end{aligned}$$

Example 2: Find the equations of tangent and normal lines to the curve given by the equation $y = xe^x$ at $(0, 0)$.

Solution: We have $y = xe^x$

$$\begin{aligned}\therefore \frac{dy}{dx} &= xe^x + e^x = e^x(1+x) \\ \left(\frac{dy}{dx}\right)_{x=0} &= 1 = \text{Slope}\end{aligned}$$

Now, Equation of the tangent line is given by

$$\begin{aligned}(y - y_1) &= m(x - x_1) \\ \therefore (y - 0) &= 1(x - 0) \quad \text{Or} \quad x - y = 0\end{aligned}$$

And equation of the normal line is given by

$$\begin{aligned}(y - y_1) &= \frac{-1}{m}(x - x_1) \\ \therefore (y - 0) &= -1(x - 0) \quad \text{Or} \quad x + y = 0\end{aligned}$$

Example 3: Find the equations of tangent and normal lines to the curve given by the equations $x = a \cos \theta$ and $y = b \sin \theta$ at the point $\theta = \frac{\pi}{4}$.

Solution: We have $x = a \cos \theta$ and $y = b \sin \theta$

$$\therefore \frac{dy}{dx} = \frac{dy/d\theta}{dx/d\theta} = \frac{b \cos \theta}{-a \sin \theta} = -\frac{b}{a} \cot \theta$$

$$\left(\frac{dy}{dx}\right)_{\theta=\pi/4} = \frac{-b}{a} = \text{Slope}$$

Now, Equation of the tangent line is given by

$$(y - y_1) = m(x - x_1)$$

Where $x_1 = a \cos \pi/4 = \frac{a}{\sqrt{2}}$ and $y_1 = b \sin \pi/4 = \frac{b}{\sqrt{2}}$

$$\therefore \left(y - \frac{b}{\sqrt{2}}\right) = \frac{-b}{a} \left(x - \frac{a}{\sqrt{2}}\right) \text{ Or } \sqrt{2}ay - ab = -\sqrt{2}bx + ab$$

$$\text{Or } \sqrt{2}(ay + bx) - 2ab = 0$$

And equation of the normal line is given by

$$(y - y_1) = \frac{-1}{m}(x - x_1)$$

$$\therefore \left(y - \frac{b}{\sqrt{2}}\right) = \frac{a}{b} \left(x - \frac{a}{\sqrt{2}}\right) \text{ Or } \sqrt{2}by - b^2 = \sqrt{2}ax - a^2$$

$$\text{Or } \sqrt{2}(ax - by) - a^2 + b^2 = 0$$

Example 4: Find the equations of tangent and normal lines to the curve given by the equations $x^2 + y^2 = 25$ at $(-3, 4)$.

Solution: We have $x^2 + y^2 = 25$

Differentiate w. r. t. 'x', we obtain

$$2x + 2y \frac{dy}{dx} = 0$$

$$\therefore \frac{dy}{dx} = \frac{-x}{y}$$

$$\left(\frac{dy}{dx}\right)_{(-3,4)} = \frac{3}{4} = \text{Slope}$$

Now, Equation of the tangent line is given by

$$(y - y_1) = m(x - x_1)$$

$$\therefore (y - 4) = \frac{3}{4}(x + 3) \text{ Or } 3x - 4y + 25 = 0$$

And equation of the normal line is given by

$$(y - y_1) = \frac{-1}{m}(x - x_1)$$

$$\therefore (y - 4) = \frac{-4}{3}(x + 3) \text{ Or } 4x + 3y = 0$$

Exercise Problems:

Find the equations of tangent and normal lines of the following equations of the curves;

1) $y = 2\sqrt{ax}$ at (x_0, y_0) 2) $y = x^2 + 2x + 1$ at $(1, 4)$ 3) $y = e^x$ at $(0, 1)$

4) $x = a \cos^3 \theta$ and $y = a \sin^3 \theta$ at the point $\theta = \frac{\pi}{4}$ 5) $x^3 + y^3 - 6xy = 0$ at (a, b)

4.2.3 Vertical Tangents

A vertical tangent to the graph of a function f occurs at a point $(a, f(a))$ if f is continuous but not differentiable at 'a'. i.e., derivative of $f(x)$ denoted by $f'(x)$ Or $\frac{dy}{dx}$ may not exist at some points. At such points either tangent does not exist or else it is parallel to the Y-axis (i.e., vertical tangent). To examine the existence of vertical tangents at $(a, f(a))$, we examine $f'(x)$ Or $\frac{dy}{dx}$ at $x = a$ must tend to infinity from both left and right side.

The normal corresponding to a vertical tangent will obviously be horizontal or parallel to X-axis. This means we can write its equation as $y = f(a)$ as it passes through $(a, f(a))$

Equivalently,

The curve $y = f(x)$ has a **vertical tangent line** at the point $(a, f(a))$ if

- 1) $f(x)$ is continuous at $x = a$.
- 2) $\lim_{x \rightarrow a} |f'(x)| = \infty$ or equivalently, $\lim_{x \rightarrow a} \frac{1}{|f'(x)|} = 0$. (When a is an end point of the domain of $f(x)$, the limit should be an appropriate side limit.

When both the conditions are satisfied, the vertical line $x = a$ is a tangent line of the curve $y = f(x)$ at the point $(a, f(a))$.

For Example: Consider the function, $f(x) = x^{1/3}$ at the point $x = 0$.

Solution: We have, $y = f(x) = x^{1/3}$ at the point $x = 0$

$$\therefore \frac{dy}{dx} = \frac{1}{3}x^{-2/3}$$

$$\Rightarrow \left(\frac{dy}{dx}\right)_{x=0} = \infty$$

Graphically, this means that the tangent is vertical. In this case the vertical tangent coincides with the Y-axis, as it is attained at the point 0.

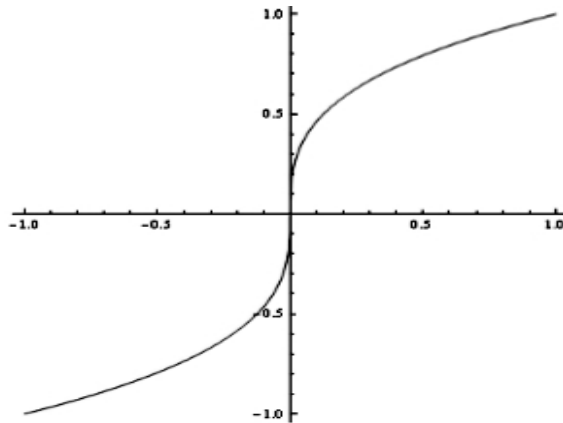

Example 1: Find all the points on the graph $y = x\sqrt{4-x^2}$ where the tangent is parallel to either axis.

Solution: We first observe the domain of the given function $y = x\sqrt{4-x^2}$ is $[-2, 2]$.

Since the horizontal tangent occur when $\frac{dy}{dx} = 0$

$$\Rightarrow \frac{dy}{dx} = (4-x^2)^{1/2} + x \cdot \frac{1}{2}(4-x^2)^{-1/2} \cdot (-2x)$$

$$= \frac{(4-x^2)}{(4-x^2)^{1/2}} - \frac{x^2}{(4-x^2)^{1/2}} = \frac{4-2x^2}{(4-x^2)^{1/2}} = 0$$

$$\therefore 4-2x^2 = 0 \text{ Or } x = \pm\sqrt{2}.$$

For $x = \sqrt{2}$ then $y = 2$ and For $x = -\sqrt{2}$ then $y = -2$

Therefore, $y = x\sqrt{4-x^2}$ has the tangent parallel to X-axis (Horizontal tangent) at $(-\sqrt{2}, f(-\sqrt{2}))$ and $(\sqrt{2}, f(\sqrt{2}))$.

And,

i) $y = x\sqrt{4-x^2}$ is right continuous at $x = -2$ and left continuous at $x = 2$

$$\text{ii) } \lim_{x \rightarrow 2} \left| \frac{4 - 2x^2}{(4 - x^2)^{1/2}} \right| = \infty \text{ and } \lim_{x \rightarrow -2} \left| \frac{4 - 2x^2}{(4 - x^2)^{1/2}} \right| = \infty$$

Therefore, $y = x\sqrt{4 - x^2}$ has the tangent parallel to Y-axis (vertical tangent) at $(2, f(2))$ and $(-2, f(-2))$.

Example 2: Find all the points on the graph $y = x^3 - x^2 - 2x$ where the tangent is parallel to either axis.

Solution: We first observe the domain of the given function

$$y = x^3 - x^2 - 2x \text{ is } [-\infty, \infty].$$

Since the horizontal tangent occur when $\frac{dy}{dx} = 0$.

$$\Rightarrow \frac{dy}{dx} = 3x^2 - 2x - 2 = 0$$

$$\therefore x = \frac{2 \pm \sqrt{4 + 24}}{6} = \frac{2 \pm 2\sqrt{17}}{6} = \frac{1 \pm \sqrt{17}}{3}$$

Therefore, $y = x^3 - x^2 - 2x$ has the tangent parallel to X-axis (Horizontal tangent) at $\left(\frac{1 + \sqrt{17}}{3}, f\left(\frac{1 + \sqrt{17}}{3}\right)\right)$ and $\left(\frac{1 - \sqrt{17}}{3}, f\left(\frac{1 - \sqrt{17}}{3}\right)\right)$.

And,

i) $y = x^3 - x^2 - 2x$ is discontinuous at $x = -\infty$ and $x = \infty$

$$\text{ii) } \lim_{x \rightarrow \infty} 3x^2 - 2x - 2 = \infty \text{ and } \lim_{x \rightarrow -\infty} 3x^2 - 2x - 2 = -\infty$$

Therefore, $y = x^3 - x^2 - 2x$ has the no tangent parallel to Y-axis (vertical tangent).

Example 3:

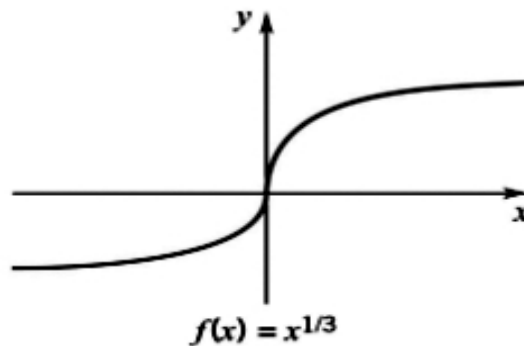

The graph of $f(x) = x^{1/3}$ has a vertical tangent at the point $(0, 0)$ since

$$f'(x) = \frac{1}{3}x^{-2/3} \rightarrow \infty \text{ as } x \rightarrow 0.$$

Example 4:

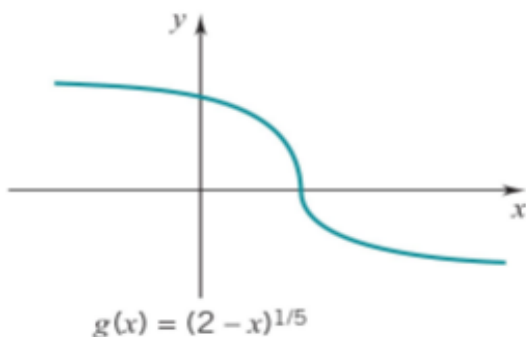

The graph of $g(x) = (2 - x)^{1/5}$ has a **vertical tangent** at the point $(2, 0)$ since

$$g'(x) = -\frac{1}{5}(2-x)^{-4/5} \rightarrow -\infty \quad \text{as } x \rightarrow 2.$$

Example 5:

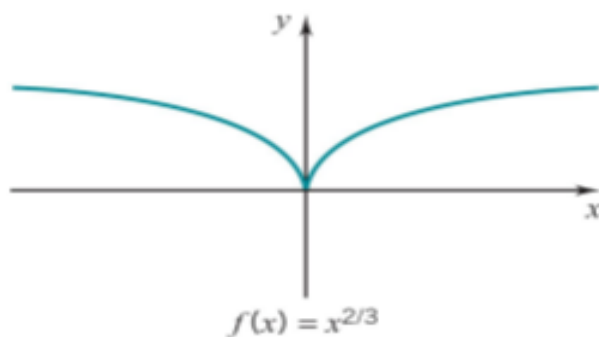

The graph of $f(x) = x^{2/3}$ has a **vertical cusp** at the point $(0, 0)$ since $f'(x) = \frac{2}{3}x^{-1/3}$ and

$$f'(x) \rightarrow -\infty \text{ as } x \rightarrow 0^-, \quad \text{and} \quad f'(x) \rightarrow \infty \text{ as } x \rightarrow 0^+.$$

Check Your Progress

Find all the points on the following graphs, where the tangent lines is either horizontal or vertical.

1) $y = \frac{x}{\sqrt{1-x^2}}$ Hint: Domain is $[-1, 1]$ 2) $y = x^{1/2} - x^{3/2}$ Hint:

Domain is $[0, \infty]$

3) $y = x^3 - x^2 - 2x$ Hint: Domain is $[-\infty, \infty]$ 4) $y = \sin x$ Hint:

Domain is $[-\infty, \infty]$.

Some More illustrations on Tangents and Normals:

Example 1: Find the equations of the tangents to the curve $y = x^3$, which are parallel to the line $12x - y - 3 = 0$.

Solution: Here, we should observe that the slope of any line parallel to the given line $12x - y - 3 = 0$ is equal to $12 - \frac{dy}{dx} = 0$ or $\frac{dy}{dx} = 12$
-----(1)

Slope of the tangent to the curve $y = x^3$ is given by $\frac{dy}{dx} = 3x^2$ -----
(2)

From equations (1) and (2), we obtain $3x^2 = 12$ Or $x^2 = 4$ Or $x = \pm 2$.

Now, for $x = 2$ then $y = (2)^3 = 8$ and for $x = -2$ then $y = (-2)^3 = -8$.

Therefore, the points at which the tangents are required are (2, 8) and (-2, -8)

The equations of the tangents are given by

$$y - 8 = 12(x - 2) \text{ Or } 12x - y + 32 = 0 \text{ and} \\ y + 8 = 12(x + 2) \text{ Or } 12x - y + 16 = 0 \text{ respectively.}$$

Example 2: Find the equations of the tangent and normal to the curve given by the equations $x = at^2$ and $y = 2at$ at the point 't'.

Solution: We have $x = at^2$ and $y = 2at$.

$$\therefore \text{Slope} = \frac{dy}{dx} = \frac{dy/dt}{dx/dt} = \frac{2a}{2at} = \frac{1}{t}$$

Therefore, the equation of the tangent at the point 't' is given by

$$(y - 2at) = \frac{1}{t}(x - at^2) \text{ Or } yt = x + at^2$$

And the equation of the normal at the point 't' is given by

$$(y - 2at) = -t(x - at^2) \text{ Or } y + tx = at(t^2 + 2)$$

Example 3: Find the equation of the tangent to the curve $x^2 + y^2 + 4x + 6y - 1 = 0$ at the point (a, b).

Solution: We have $x^2 + y^2 + 4x + 6y - 1 = 0$. Then, its slope is given by

$$2x + 2y \frac{dy}{dx} + 4 + 6 \frac{dy}{dx} = 0 \text{ Or } (2y + 6) \frac{dy}{dx} = -(2x + 4)$$

$$\text{Or } \frac{dy}{dx} = \frac{-(x+2)}{(y+3)} \Rightarrow \left(\frac{dy}{dx} \right)_{(a,b)} = \frac{-(a+2)}{(b+3)}$$

Therefore, the equation of the tangent to the curve at the point (a, b) is given by

$$(y - b) = \frac{-(a+2)}{(b+3)}(x - a).$$

Example 4: Prove that the line $2x + 3y = 1$ touches the curve $3y = e^{-2x}$ at a point whose X-coordinate is zero.

Solution: We have, the equation of the curve as $3y = e^{-2x}$. Its slope is given by

$$3 \frac{dy}{dx} = -2e^{-2x} \Rightarrow \left(\frac{dy}{dx} \right)_{x=0} = \frac{-2}{3}$$

The point on the curve is given by ; at $x = 0$, $y = \frac{e^{-2x}}{3}$ gives $y = \frac{1}{3}$

\therefore The point is $\left(0, \frac{1}{3} \right)$.

Therefore, the equation of the tangent is given by

$$(y - \frac{1}{3}) = \frac{-2}{3}(x - 0) \text{ Or } 3y - 1 = -2x \text{ Or } 2x + 3y = 1. \text{ Hence proved.}$$

Example 5: Prove that the equation of the normal to the hyperbola

$$\frac{x^2}{a^2} - \frac{y^2}{b^2} = 1 \text{ at a point } (a\sqrt{2}, b) \text{ is } ax + b\sqrt{2}y = (a^2 + b^2)\sqrt{2}.$$

Solution: We have, the equation of the curve as $\frac{x^2}{a^2} - \frac{y^2}{b^2} = 1$. To find the slope,

$$\frac{2x}{a^2} - \frac{2y}{b^2} \frac{dy}{dx} = 0 \Rightarrow \left(\frac{dy}{dx} \right) = \frac{-2x}{a^2} \times \frac{b^2}{2y} = \frac{b^2 x}{a^2 y}$$

$$\therefore \left(\frac{dy}{dx} \right)_{(a\sqrt{2}, b)} = \frac{b^2(a\sqrt{2})}{a^2 b} = \frac{\sqrt{2}b}{a}$$

Therefore, equation of the normal at the point $(a\sqrt{2}, b)$ is given by

$$(y - b) = \frac{-a}{\sqrt{2}b}(x - a\sqrt{2}) \quad \text{Or} \quad b\sqrt{2}(y - b) = -ax + a^2\sqrt{2}$$

$$\text{Or } (b\sqrt{2})y - b^2\sqrt{2} = -ax + a^2\sqrt{2} \quad \text{Or } ax + (b\sqrt{2})y = (a^2 + b^2)\sqrt{2}.$$

Hence Proved.

Check Your Progress

1. Find the equations of the tangent and normal to the curve given by the equations $x = a(t + \sin t)$ and $y = a(1 - \cos t)$ at the point 't'.
2. Find the equation of the tangent to the curve $xy = a$ at the point (a, b) .

4.3 Angles of intersection of two curves

When two curves intersect at a point, their angle of intersection at that point is defined with the help of their tangents at that point.

i.e., the angle of intersection of two curves is the angle between their tangents at their point of intersection.

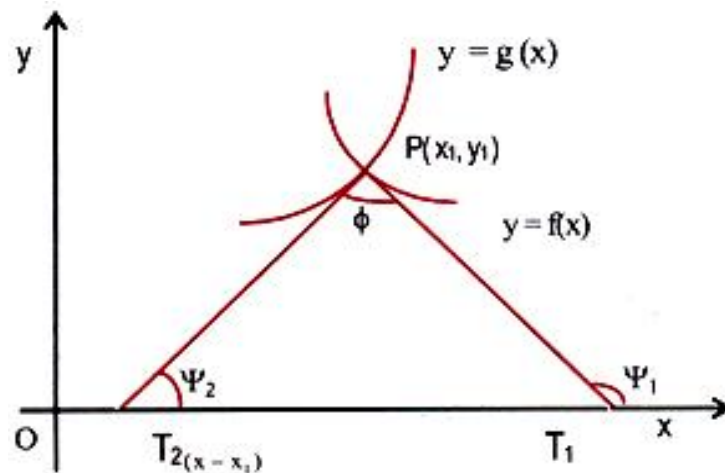

Here two curves $y = f(x)$ and $y = g(x)$ are intersecting at the point $P(x_1, y_1)$. The angle of intersection of these two curves at the point P is an angle between the tangents T_1 and T_2 to these curves at P such that

$$0 \leq \phi \leq \frac{\pi}{2}.$$

In other words,

In order to measure the angle between two curves, we measure the angle between the tangents to the curves at that point. It is obtained by the formula, $\tan \phi = \tan(\psi_1 - \psi_2)$ (From the figure).

Now, by trigonometry, $\tan \phi = \frac{\tan \psi_1 - \tan \psi_2}{1 + \tan \psi_1 \tan \psi_2}$. Where $\tan \psi_1$ and $\tan \psi_2$ are slopes of the tangent lines T_1 and T_2 to the curves $y = f(x)$ and $y = g(x)$ at their point of intersection $P(x_1, y_1)$.

Note:

- 1) The above figure shows that $\psi_1 - \psi_2$ to be an acute angle. Then angle $\theta = \pi - (\psi_1 - \psi_2)$, since we take angle of intersection as an acute angle.
- 2) But in the following figure, it is difficult to decide about whether we should take $\tan \phi = \tan(\psi_1 - \psi_2)$ or $\tan \phi = \pi - \tan(\psi_1 - \psi_2) = -\tan(\psi_1 - \psi_2)$. Therefore, we decide to take $\tan \phi = \tan(\psi_1 - \psi_2)$ if $0 \leq \phi \leq \frac{\pi}{2}$

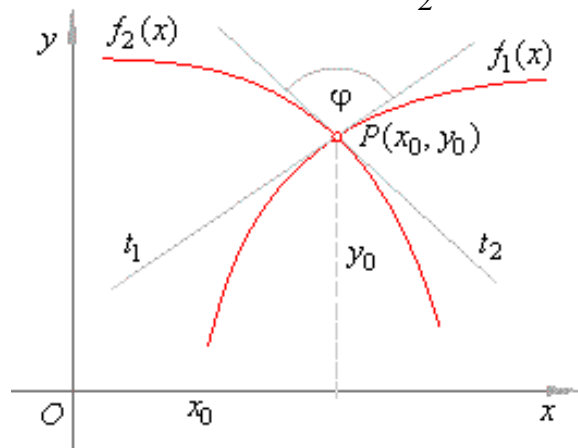

- 3) Two curves $y = f(x)$ and $y = g(x)$ touch each other at the point $P(x_1, y_1)$, then they will have a common tangent at $P(x_1, y_1)$. This is possible iff $\theta = 0$ and $\tan \psi_1 = \tan \psi_2$.
- 4) Two curves $y = f(x)$ and $y = g(x)$ intersect each other at the point $P(x_1, y_1)$ at right angles or orthogonally iff $\tan \psi_1 \cdot \tan \psi_2 = -1$.

Example 1: Find the angle of intersection of the parabola $y^2 = 2x$ and the circle $x^2 + y^2 = 8$.

Solution: Let's find the points of intersection of the given curves.

Consider, $x^2 + y^2 = 8$ put $y^2 = 2x$ then $x^2 + 2x - 8 = 0 \Rightarrow x = 2, -4$.

For $x = 2$, $y^2 = 2x$ gives $y = \pm 2$ and For $x = -4$, $y^2 = 2x$ gives $y = \pm 2i\sqrt{2}$ (Imaginary values).

Therefore, the considerable values of points of intersection are only (2, 2) and (2, -2).

Now, differentiate both equations of curves $y^2 = 2x$ and $x^2 + y^2 = 8$ with respect to 'x', we obtain, $y^2 = 2x \Rightarrow 2y \frac{dy}{dx} = 2$ Or $\frac{dy}{dx} = \frac{1}{y}$

$$\therefore \left(\frac{dy}{dx}\right)_{(2,2)} = \frac{1}{2} \text{ and } \left(\frac{dy}{dx}\right)_{(2,-2)} = -\frac{1}{2}$$

$$\text{And, } x^2 + y^2 = 8 \Rightarrow 2x + 2y \frac{dy}{dx} = 0 \text{ Or } \frac{dy}{dx} = \frac{-x}{y}$$

$$\therefore \left(\frac{dy}{dx}\right)_{(2,2)} = -1 \text{ and } \left(\frac{dy}{dx}\right)_{(2,-2)} = 1.$$

At the point (2, 2), let $\tan \psi_1 = \frac{1}{2}$ and $\tan \psi_2 = -1$

The angle of intersection of the given two curves at the point (2, 2) is;

$$\tan \phi = \frac{\tan \psi_1 - \tan \psi_2}{1 + \tan \psi_1 \tan \psi_2} = \frac{\frac{1}{2} - (-1)}{1 + \frac{1}{2} \cdot (-1)} = \frac{3/2}{1/2} = 3$$

$$\therefore \phi = \tan^{-1} 3$$

Similarly,

At the point (2, -2), let $\tan \psi_1 = -\frac{1}{2}$ and $\tan \psi_2 = 1$.

The angle of intersection of the given two curves at the point (2, -2) is;

$$\tan \phi = \frac{\tan \psi_1 - \tan \psi_2}{1 + \tan \psi_1 \tan \psi_2} = \frac{-\frac{1}{2} - 1}{1 + (-\frac{1}{2}) \cdot (1)} = \frac{-3/2}{1/2} = -3$$

$$\therefore \phi = \tan^{-1}(-3).$$

Example 2: Find the angle of intersection of the parabolas $y^2 = 4x$ and the circle $x^2 = 4y$.

Solution: Let's find the points of intersection of the given curves.

Consider, $x^2 = 4y$ put $x = y^2/4$ then

$$\left(\frac{y^2}{4}\right)^2 = 4y \text{ Or } y^4 - 64y = 0 \text{ Or } y(y^3 - 64) = 0 \Rightarrow y = 0, 4.$$

For $y = 0$, $x^2 = 4y$ gives $x = 0$ and $y = 4$, $x^2 = 4y$ gives $x = \pm 4$.

Therefore, the points of intersection are (0, 0) and (4, 4)

Now, differentiate both equations of curves $y^2 = 4x$ and $x^2 = 4y$ with

respect to 'x', we obtain, $y^2 = 4x \Rightarrow 2y \frac{dy}{dx} = 4$ Or $\frac{dy}{dx} = \frac{2}{y}$.

$$\therefore \left(\frac{dy}{dx}\right)_{(0,0)} = \infty \text{ and } \left(\frac{dy}{dx}\right)_{(4,4)} = \frac{1}{2}$$

And, $x^2 = 4y \Rightarrow 2x = 4 \frac{dy}{dx} = 0$ Or $\frac{dy}{dx} = \frac{x}{2}$

$$\therefore \left(\frac{dy}{dx}\right)_{(0,0)} = 0 \text{ and } \left(\frac{dy}{dx}\right)_{(4,4)} = 2.$$

At the point (0, 0), let $\tan \psi_1 = \infty$ and $\tan \psi_2 = 0$

The angle of intersection of the given two curves at the point (0, 0) is;

$$\tan \phi = \frac{\tan \psi_1 - \tan \psi_2}{1 + \tan \psi_1 \tan \psi_2} = \frac{\infty - 0}{1 + (\infty) \cdot (0)} = \infty$$

$$\therefore \phi = \tan^{-1}(\infty) = \frac{\pi}{2}$$

Similarly,

At the point (4, 4), let $\tan \psi_1 = \frac{1}{2}$ and $\tan \psi_2 = 2$.

The angle of intersection of the given two curves at the point (4, 4) is;

$$\tan \phi = \frac{\tan \psi_1 - \tan \psi_2}{1 + \tan \psi_1 \tan \psi_2} = \frac{\frac{1}{2} - (2)}{1 + \left(\frac{1}{2}\right) \cdot (2)} = \frac{-3/2}{2} = \frac{-3}{4}$$

$$\therefore \phi = \tan^{-1}\left(\frac{-3}{4}\right)$$

Example 3: Show that the curves $x^2 + 4y^2 = 8$ (Ellipse) and $x^2 - 2y^2 = 4$ (Hyperbola) cut each other orthogonally at four points.

Solution: Let's find the points of intersection of the given curves.

Consider, $x^2 + 4y^2 = 8$ put $x^2 = 4 + 2y^2$ then
 $4 + 2y^2 + 4y^2 = 8$ Or $6y^2 = 4$ Or $y^2 = \frac{4}{6} = \frac{2}{3}$ Or $y = \pm\sqrt{\frac{2}{3}}$.

For

$$y = \pm\sqrt{\frac{2}{3}}, x^2 + 4y^2 = 8 \text{ gives } x^2 + 4\left(\frac{2}{3}\right) = 8 \text{ Or } x^2 = \frac{16}{3} \text{ Or } x = \pm\frac{4}{\sqrt{3}} .$$

Therefore, the four points of intersection are $\left(\frac{4}{\sqrt{3}}, \pm\sqrt{\frac{2}{3}}\right)$ and

$$\left(-\frac{4}{\sqrt{3}}, \pm\sqrt{\frac{2}{3}}\right).$$

Now, the condition for two curves $y = f(x)$ and $y = g(x)$ to intersect each other at the point $P(x_1, y_1)$ at right angles or orthogonally is $\tan\psi_1 \cdot \tan\psi_2 = -1$.

Where, $\tan\psi_1 = \frac{dy}{dx}$ of the curve $x^2 + 4y^2 = 8$.

$$\therefore 2x + 8y \frac{dy}{dx} = 0 \text{ Or } \frac{dy}{dx} = \frac{-x}{4y} \Rightarrow \left(\frac{dy}{dx}\right)_{\left(\frac{4}{\sqrt{3}}, \sqrt{\frac{2}{3}}\right)} = -\frac{1}{\sqrt{2}} .$$

And, $\tan\psi_2 = \frac{dy}{dx}$ of the curve $x^2 = 4 + 2y^2$

$$\therefore 2x = 4y \frac{dy}{dx} \text{ Or } \frac{dy}{dx} = \frac{x}{2y} \Rightarrow \left(\frac{dy}{dx}\right)_{\left(\frac{4}{\sqrt{3}}, \sqrt{\frac{2}{3}}\right)} = \frac{2}{\sqrt{2}} = \sqrt{2}$$

Thus, $\tan\psi_1 \cdot \tan\psi_2 = \frac{-1}{\sqrt{2}} \cdot \sqrt{2} = -1$. Therefore, the curves intersect orthogonally.

Similarly, it can be shown in remaining three points also.

Example 4: Show that the curves $xy = a^2$ and $x^2 + y^2 = 2a^2$ touch each other at two points.

Solution: Let's find the points of intersection of the given curves.

Consider, $x^2 + y^2 = 2a^2$ put $y = \frac{a^2}{x}$ then

$$x^2 + \left(\frac{a^2}{x}\right)^2 = 2a^2 \text{ Or } x^4 - 2a^2x^2 + a^4 = 0 \text{ Or } (x^2 - a^2)^2 = 0 \text{ Or } x = \pm a$$

(Twice).

For $x = a$, $y = \frac{a^2}{x}$ gives $y = a$ and For $x = -a$, $y = \frac{a^2}{x}$ gives $y = -a$

Therefore, the four points of intersection are (a, a) and $(-a, -a)$.

Now, the condition for two curves $y = f(x)$ and $y = g(x)$ to touch each other at the point $P(x_1, y_1)$ at right angles or orthogonally is $\tan \psi_1 = \tan \psi_2$.

Where, $\tan \psi_1 = \frac{dy}{dx}$ of the curve $xy = a^2$.

$$\therefore y + x \frac{dy}{dx} = 0 \text{ Or } \frac{dy}{dx} = \frac{-y}{x} \Rightarrow \left(\frac{dy}{dx}\right)_{(a, a)} = -1.$$

And, $\tan \psi_2 = \frac{dy}{dx}$ of the curve $x^2 + y^2 = 2a^2$

$$\therefore 2x + 2y \frac{dy}{dx} = 0 \text{ Or } \frac{dy}{dx} = \frac{-x}{y} \Rightarrow \left(\frac{dy}{dx}\right)_{(a, a)} = -1$$

Thus, $\tan \psi_1 = \tan \psi_2 = -1$. Therefore, the curves touch each other.

Similarly, it can be shown at another point.

4.4. Polar Coordinate System

We already know that, for a given pair of axes in a plane, the position of a point in the plane (known as Cartesian plane or Cartesian coordinate system) can be determined if we know its distances from the X-axis and Y-axis. The coordinates (x, y) are also known as rectangular coordinates. There is one more way in which we can determine the position of the point by its initial line OX in a plane known as polar plane or polar coordinate system.

A coordinate system in which the position of a point $P(r, \theta)$ called as polar coordinates of the position of the point P (known as polar coordinate system or polar plane) is given by its radial distance 'r' from the origin 'O' and the angle 'θ' measured counter clockwise from a horizontal line OX called the polar axis to the line OP as shown in the figure. The line OP from the origin to the point is called the radius vector, the angle θ is called the polar angle, and the origin O is called the pole.

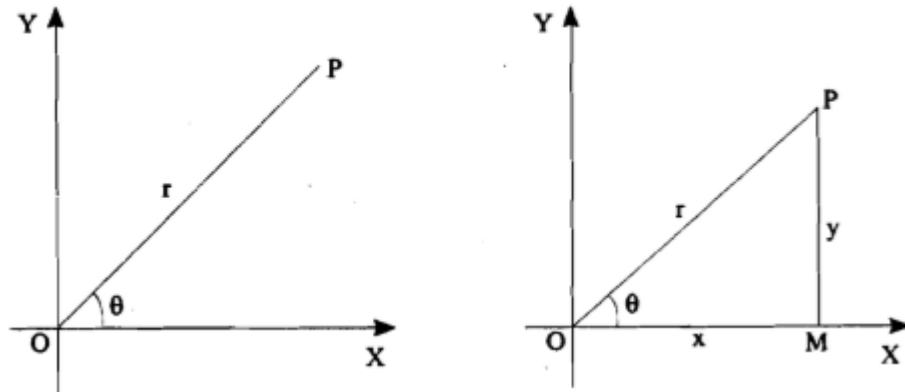
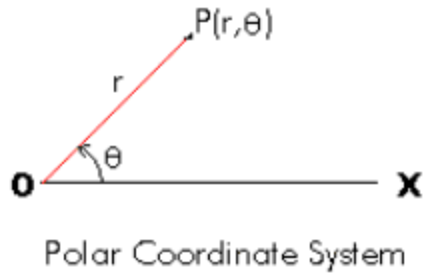

Polar coordinate system

4.4.1 Transformations between Polar and Rectangular Coordinates

The formulae for conversion from rectangular to polar coordinates Or vice versa are given by $x = r \cos \theta$ and $y = r \sin \theta$.

These relations gives $r = \sqrt{x^2 + y^2}$ and $\theta = \tan^{-1}\left(\frac{y}{x}\right)$.

The equation of a curve in polar form is expressed as $r = f(\theta)$.

For example: The equation of the circle having Centre at origin O and radius r is given by $r = a$

Remarks:

- 1) The slope of the polar coordinates is given by

$$\frac{dy}{dx} = \frac{dy/d\theta}{dx/d\theta} = \frac{\sin \theta \frac{dr}{d\theta} + r \cos \theta}{\cos \theta \frac{dr}{d\theta} - r \sin \theta}$$

- 2) The angle between the radius vector and the tangent to the curve (measured counterclockwise) is an important angle that plays a role in polar coordinates somewhat similar to that of the slope in rectangular coordinates. It is given by $\tan \psi = r \frac{d\theta}{dr}$. It is shown in the following figure.

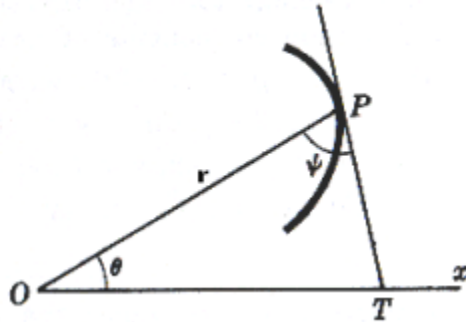

- 3) The angle of intersection ϕ between two curves C_1 and C_2 meeting at a point P , is given by $\tan \phi = \frac{\tan \psi_2 - \tan \psi_1}{1 + \tan \psi_1 \tan \psi_2}$ where ψ_1 and ψ_2 are the angles from the radius vector OP to the respective tangents to the curves at the point P . ϕ is the angle measured counterclockwise from the tangent of the curve C_1 to the tangent of the curve C_2 as shown in the following figure.

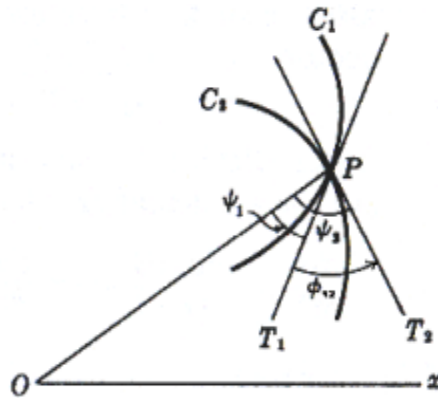

- 4) The angle ϕ is also given by $\phi = |\psi_2 - \psi_1|$
 5) If $\tan \psi_1 \tan \psi_2 = -1$, then the curves cut orthogonally.

Example 1: Find the angle between the radius vector and tangent to the curve $r^2 = a^2 \cos 2\theta$

Solution: The angle between the radius vector and tangent to the curve is given by

$$\tan \psi = r \frac{d\theta}{dr} \Rightarrow \tan \psi = \frac{a\sqrt{\cos 2\theta}}{-2a^2 \sin 2\theta} \cdot 2a\sqrt{\cos 2\theta} = \frac{2a^2 \cos 2\theta}{-2a^2 \sin 2\theta} = -\cot 2\theta$$

$$\therefore \tan \psi = -\cot 2\theta \Rightarrow \tan \psi = \tan \left[(2n+1)\frac{\pi}{2} + 2\theta \right] \text{ Or } \psi = (2n+1)\frac{\pi}{2} + 2\theta$$

Example 2: Find the angle between the radius vector and tangent to the curve $\frac{1}{r} = (1 + e \cos \theta)$

Solution: The angle between the radius vector and tangent to the curve is

$$\tan \psi = r \frac{d\theta}{dr} \Rightarrow \tan \psi = \frac{1}{1 + e \cos \theta} \cdot \frac{1}{\frac{-1}{(1 + e \cos \theta)^2} \cdot (-e \sin \theta)}$$

given by
$$= \frac{(1 + e \cos \theta)^2}{e \sin \theta (1 + e \cos \theta)} = \frac{(1 + e \cos \theta)}{e \sin \theta}$$

$$\text{Or } \psi = \tan^{-1} \left[\frac{(1 + e \cos \theta)}{e \sin \theta} \right]$$

Example 3: Find the angle between the radius vector and tangent to the curve $r = a^m \cos m\theta$

Solution: The angle between the radius vector and tangent to the curve is given by

$$\tan \psi = r \frac{d\theta}{dr} \Rightarrow \tan \psi = a^m \cos m\theta \cdot \frac{1}{-ma^m \sin m\theta} = -\frac{1}{m} \cot m\theta$$

$$\text{Or } m \tan \psi = \tan \left[(2n+1)\frac{\pi}{2} + m\theta \right] \Rightarrow \psi = \left[(2n+1)\frac{\pi}{2} + m\theta \right]$$

Example 4: Find the angle between the radius vector and tangent to the curve $r = a^m (\cos m\theta - \sin m\theta)$

Solution: The angle between the radius vector and tangent to the curve is given by

$$\begin{aligned} \tan \psi = r \frac{d\theta}{dr} &\Rightarrow \tan \psi = a^m (\cos m\theta - \sin m\theta) \cdot \frac{1}{-a^m (m \sin m\theta + m \cos m\theta)} \\ &= -\frac{(\cos m\theta - \sin m\theta)}{m(\cos m\theta + \sin m\theta)} = -\frac{(1 - \tan m\theta)}{m(1 + \tan m\theta)} \\ &= -\frac{1}{m} \cdot \frac{\tan \frac{\pi}{4} - \tan m\theta}{1 - \tan \frac{\pi}{4} \tan m\theta} = \frac{-1}{m} \tan \left(\frac{\pi}{4} - m\theta \right) = \frac{1}{m} \tan \left(m\theta - \frac{\pi}{4} \right) \end{aligned}$$

$$\text{Or } m \tan \psi = \tan \left(m\theta - \frac{\pi}{4} \right) \Rightarrow \psi = \left(m\theta - \frac{\pi}{4} \right)$$

$$\text{Or } m \tan \psi = \tan \left[(2n+1)\frac{\pi}{2} + m\theta \right] \Rightarrow \psi = \left[(2n+1)\frac{\pi}{2} + m\theta \right]$$

Illustrations on Angle of intersection of polar curves:

Example 1: Find the angle of intersection of the curves $r = a \cos 2\theta$ and $r = a \sin 2\theta$.

Solution: We have the equations of the curves; $r = a \cos 2\theta$ and $r = a \sin 2\theta$

Solving both we $a \cos 2\theta = a \sin 2\theta \Rightarrow \cos 2\theta = \sin 2\theta$ obtain,
 $\sin 2\theta$ Or $\tan 2\theta = 1$.

Now,

Let ψ_1 be the angle between the radius vector and tangent to the curve $r = a \cos 2\theta$. Then,

$$\tan \psi_1 = r \frac{d\theta}{dr} = \frac{a \cos 2\theta}{\frac{dr}{d\theta}} = \frac{a \cos 2\theta}{-2a \sin 2\theta} = \frac{-1}{2} \tan 2\theta = \frac{-1}{2}$$

and let ψ_2 be the angle between the radius vector and tangent to the curve $r = a \sin 2\theta$. Then,

$$\tan \psi_2 = r \frac{d\theta}{dr} = \frac{a \cos 2\theta}{\frac{dr}{d\theta}} = \frac{a \sin 2\theta}{2a \cos 2\theta} = \frac{1}{2} \tan 2\theta = \frac{1}{2}$$

Therefore the angle of intersection of given two polar curves is;

$$\tan \phi = \frac{\tan \psi_2 - \tan \psi_1}{1 + \tan \psi_1 \tan \psi_2}$$

$$\therefore \tan \phi = \frac{\frac{1}{2} - \left(\frac{-1}{2}\right)}{1 + \frac{1}{2} \cdot \left(\frac{-1}{2}\right)} = \frac{1}{1 - \frac{1}{4}} = \frac{4}{3} \text{ Or } \phi = \psi_1 - \psi_2 = \tan^{-1}\left(\frac{4}{3}\right)$$

Example 2: Find the angle of intersection of the curves $r = ae^\theta$ and $re^\theta = b$.

Solution: We have the equations of the curves; $r = ae^\theta$ and $re^\theta = b$.

Solving both we obtain,

$$ae^\theta = be^{-\theta} \Rightarrow e^{2\theta} = \frac{b}{a} \text{ Or } 2\theta = \log\left(\frac{b}{a}\right) \text{ Or } \theta = \frac{1}{2} \log\left(\frac{b}{a}\right)$$

Now,

Let ψ_1 be the angle between the radius vector and tangent to the curve

$$r = ae^\theta. \text{ Then, } \tan \psi_1 = r \frac{d\theta}{dr} = \frac{ae^\theta}{\frac{dr}{d\theta}} = \frac{ae^\theta}{ae^\theta} = 1$$

and let ψ_2 be the angle between the radius vector and tangent to the curve $r = be^{-\theta}$. Then,

$$\tan \psi_2 = r \frac{d\theta}{dr} = \frac{be^{-\theta}}{\frac{dr}{d\theta}} = \frac{be^{-\theta}}{-be^{-\theta}} = -1$$

Therefore the angle of intersection of given two polar curves is;

$$\tan \phi = \frac{\tan \psi_2 - \tan \psi_1}{1 + \tan \psi_1 \tan \psi_2}$$

$$\therefore \tan \phi = \frac{-1-1}{1+1(-1)} = \infty \text{ Or } \phi = \psi_1 - \psi_2 = \tan^{-1} \infty = \frac{\pi}{2}$$

Note: Here it is observed that $\tan \psi_1 \tan \psi_2 = -1$ this implies that the curves cut orthogonally.

Example 3: Find the angle of intersection of the curves $r = a(1 + \sin \theta)$ and $r = a(1 - \sin \theta)$.

Solution: We have the equations of the curves; $r = a(1 + \sin \theta)$ and $r = a(1 - \sin \theta)$

Solving both we obtain, $a(1 + \sin \theta) = a(1 - \sin \theta) \Rightarrow 2 \sin \theta = 0$ Or $\theta = 0$.

Now,

Let ψ_1 be the angle between the radius vector and tangent to the curve $r = a(1 + \sin \theta)$. Then,

$$\tan \psi_1 = r \frac{d\theta}{dr} = \frac{a(1 + \sin \theta)}{dr/d\theta} = \frac{a(1 + \sin \theta)}{a \cos \theta} = \frac{(1 + \sin \theta)}{\cos \theta} = 1$$

and let ψ_2 be the angle between the radius vector and tangent to the curve $r = a(1 - \sin \theta)$. Then,

$$\tan \psi_2 = r \frac{d\theta}{dr} = \frac{a(1 - \sin \theta)}{dr/d\theta} = \frac{a(1 - \sin \theta)}{-a \cos \theta} = -\frac{(1 - \sin \theta)}{\cos \theta} = -1$$

Therefore the angle of intersection of given two polar curves is;

$$\tan \phi = \frac{\tan \psi_2 - \tan \psi_1}{1 + \tan \psi_1 \tan \psi_2}$$

$$\therefore \tan \phi = \frac{-1-1}{1+1(-1)} = \infty \text{ Or } \phi = \psi_1 - \psi_2 = \tan^{-1} \infty = \frac{\pi}{2}$$

Note: Here it is observed that $\tan \psi_1 \tan \psi_2 = -1$ this implies that the curves cut orthogonally.

4.5 Tangents at the origin

To find the nature of the multiple points it is required to find the tangent or tangents at that point. The following rule is very helpful in this case:

Rule: If a curve passing through the origin and is given by a rational, integral, algebraic equation then the equation of the tangent or tangents at the origin is obtained by equating to zero the lowest degree terms in the curve.

Let the equation of the curve be written as:

$$(a_1x + a_2y) + (b_1x^2 + b_2xy + b_3y^2) + (c_1x^3 + c_2xy^2 + c_3y^3) + \dots = 0 \dots (1)$$

Let $p(x, y)$ be any point on the curve. The slope of curve is $\frac{y}{x}$. Then the equation of OP is

Equation of the tangent at O is given by

$$Y = \left\{ \lim_{x \rightarrow 0} \left(\frac{y}{x} \right) \cdot X \right\} \dots \dots \dots (2)$$

Here we exclude the case when the tangent is Y axis i.e. $\lim_{x \rightarrow 0} \left(\frac{y}{x} \right) = \pm \infty$ we now have:

Case 1: Let $a_2 \neq 0$ divided (1) by x and taking limit $x \rightarrow 0$ we get $a_1 + a_2 \left(\lim_{x \rightarrow 0} \left(\frac{y}{x} \right) \right) = 0 \dots \dots \dots (3)$

Eliminating $\lim_{x \rightarrow 0} \left(\frac{y}{x} \right)$ between (2) & (3), we get

$$a_1X + a_2Y = 0$$

Or written x, y for X and Y , the tangent at the origin to (1) is

$$a_1x + b_2y = 0$$

which is obtained by equating to zero the terms of the lowest degree term in (1) of $a_2 = 0$ then $a_1 = 0$ by (3) so we have the next case.

Case 2: when $a_1 = 0$, $a_2 = 0$ but b_2 & b_3 both are not zero, then dividing (1) by x^2 & taking the limit $x \rightarrow 0$ we get

$$b_1 + b_2 \lim_{x \rightarrow 0} \left(\frac{y}{x} \right) + b_3 \lim_{x \rightarrow 0} \left(\frac{y}{x} \right)^2 = 0$$

Or $b_1 + b_2 m + b_3 m^2 = 0 \dots \dots \dots (4)$

So we get two values of m in general giving two tangents at the origin. The equation of tangents is obtained by elimination of m between (2) and (4) so we get

$$b_1 + b_2xy + b_3y^2 = 0$$

which is the same by equating to zero the terms of the lowest degree term in equation of the curve.

Also if $b_2 = 0$, $b_3 = 0$ then from (4) $b_1 = 0$

Case 3: If $a_1 = a_2 = b_1 = b_2 = b_3 = 0$ we can show as above that the Rule is true.

Hence by equating to zero the terms of the lowest degree term all the tangents at origin are obtained including Y axis (if it is tangent).

Example 1: Show that origin is a node for the curve

$$y^2(a^2 + x^2) = x^2(a^2 - x^2)$$

Solution: Equating to zero the lowest degree terms in the equation of the curve the tangents at the origin are given by

$$a^2y^2 - a^2x^2 = 0 \text{ or } y = \pm x$$

\therefore the tangents are real & distinct and so the origin is a node.

Example 2: Show that origin is a conjugate point for the curve

$$x^4 - ax^2y + axy^2 + a^2y^2 = 0$$

Solution: Equating to zero the lowest degree terms in the given equation, the tangent at the origin is given by:

$$a^2y^2 = 0 \text{ or } y^2 = 0, \text{ or } y = 0, y = 0$$

So the tangents are real & coincident at $(0, 0)$

Therefore origin is either a cusp or a conjugate point.

Now equation of the curve can be written as

$$ay^2(x + a) - ax^2y + x^4 = 0$$

$$\therefore y = \frac{ax^2 \pm \sqrt{a^2x^4 - 4ax^4(x+a)}}{2a(x+a)}$$

$$= \frac{ax^2 \pm x^2\sqrt{-4ax - 3a^2}}{2a(x+a)}$$

Since for very small value of $x (\neq 0)$

$$-4ax - 3a^2 < 0$$

\therefore y is imaginary in the neighborhood of origin. Hence origin is a conjugate point.

4.6 Summary

In this unit, we have discussed and studied the equation of tangent and normal to a curve at given point in Cartesian form, parametric form,

tangent parallel to the X axis or a given, angle of intersection of two curves and equation of tangent at origin.

4.7 Terminal Questions

- Find the equation of the tangent at the point (p,q) on the curves.
 - $\frac{x^m}{a^m} + \frac{y^m}{b^m} = 1$
 - $(x^2 + y^2)^2 = a^2(x^2 - y^2)$
- Find the point on the curve $y = x^{\frac{2}{3}} \cdot (x + a)^{\frac{1}{3}}$ at which the tangent is (a) parallel to x axis (b) parallel to y axis.
- Find the equation of tangent at the point 't' on the curve
 $x = a(t + \sin t)$, $y = a(1 - \cos t)$.
- Show that the condition that the curves $ax^2 + by^2 = 1$ & $a_1x^2 + b_1y^2 = 1$ should cut orthogonally is $\frac{1}{a} - \frac{1}{b} = \frac{1}{a_1} - \frac{1}{b_1}$.
- Find the equation of the normal to the curve $y(x-2)(x-3) - x + 7 = 0$ at the point where it cuts the axis of X .
- Show that the normal at any point on the curve $x = a \cos \theta + a \theta \sin \theta$, $y = a \sin \theta - a \theta \cos \theta$ is at a constant distance from the origin.

RIL-146

UGMM-103/106



Uttar Pradesh Rajarshi Tandon
Open University

UGMM-103

Integral Calculus

BLOCK

2

INTEGRAL CALCULUS

UNIT 5	109-132
--------	---------

Tracing of Curves

UNIT 6	133-158
--------	---------

Area Under a Curve

UNIT 7	159-172
--------	---------

Volume of a solid of Revolution

Curriculum Design Committee

Dr. Ashutosh Gupta, Director, School of Science, UPRTOU, Prayagraj	Coordinator
Prof. Sudhir Kumar Srivastava Dept. of Mathematics, Pt. Deen Dayal Upadhyay University, Gorakhpur	Member
Prof. P.K. Singh Dept. of Mathematics, University of Allahabad, Prayagraj	Member
Prof. Himanshu Pandey Dept. of Mathematics, Pt. Deen Dayal Upadhyay University, Gorakhpur	Member
Dr. Vikash Singh Academic Consultant- Mathematics, School of Science, UPRTOU, Prayagraj.	Member Secretary
Dr. Sankar Saran Tripathi Academic Consultant- Mathematics, School of Science, UPRTOU, Prayagraj	Spl. Invited Member

Course Design Committee

Faculty Members, School of Sciences

Dr. Ashutosh Gupta, Director, School of Science, UPRTOU, Prayagraj.
Dr. Shruti, Asst. Prof. (Statistics), School of Science, UPRTOU, Prayagraj
Dr. Marisha Asst. Prof. (Computer Science), School of Science, UPRTOU, Prayagraj
Mr. Manoj K Balwant Asst. Prof. (Computer Science), School of Science, UPRTOU, Prayagraj
Dr. Dinesh K Gupta Academic Consultant (Chemistry), School of Science, UPRTOU, Prayagraj
Dr. S.S. Tripathi, Academic Consultant (Maths), School of Science, UPRTOU, Prayagraj
Dr. Dharamveer Singh, Academic Consultant (Bio-Chemistry),
School of Science, UPRTOU, Prayagraj
Dr. R.P. Singh, Academic Consultant (Bio-Chemistry), School of Science, UPRTOU, Prayagraj
Dr. Susma Chauhan, Academic Consultant (Botany), School of Science, UPRTOU, Prayagraj
Dr. Deepa Chaubey, Academic Consultant (Zoology), School of Science, UPRTOU, Prayagraj

Course Preparation Committee

Dr. Vikas Singh Dept. of Mathematics Academic Consultant-Mathematics, School of Science, UPRTOU, Prayagraj	(Block-1; Unit-1,2,3,4, and Block-2; Unit-5,6 & 7)	Author
Dr. S.S. Tripathi Academic Consultant-Mathematics, School of Science, JPRTOU, Prayagraj.		Editor
Dr. S.S. Tripathi Academic Consultant-Mathematics, School of Science, UPRTOU, Prayagraj		SLM Coordinator

© UPRTOU, Prayagraj. 2020
ISBN : 978-93-83328-50-5

*All Rights are reserved. No part of this work may be reproduced in any form, by mimeograph or any other means, without permission in writing from the **Uttar Pradesh Rajarshi Tondon Open University, Prayagraj.***

UNIT-5

TRACING OF CURVES

Structure

- 5.1 Introduction
 - Objectives
- 5.2 Singular points
- 5.3 Double points and its classification
- 5.4 Nature of the cusp at the origin
- 5.5 A necessary condition for the existence of the double points on a curve
- 5.6 Asymptotes
 - 5.6.1 The (oblique) asymptotes of the general algebraic curves
 - 5.6.2 Simple method to find the asymptotes of a given curve
 - 5.6.3 Two parallel asymptotes
- 5.7 Curve Tracing
 - 5.7.1 Procedure
- 5.8 Summary
- 5.9 Terminal Questions

5.1 Introduction

In this unit, the concept of regular points, singularity points and multiple points are explained. The double point and its classification, types of cusps and its explanation of nature at the origin is explained which is very essential to trace the curve. Whether double points exist in a curve is explained and what is the necessary condition for the existence is discussed. A detailed study of asymptotes for general algebraic curve is provided along with the simple steps to find the asymptotes of a given curve. At last, we will see the procedure to trace the curve using the concepts studied in the unit.

Objectives

After reading this unit you should be able to :

- Understand the concept of singular points and regular points
- Knows Double points and its classification
- Understand the different types of cusp and nature of cusp at origin
- Understand the concept of asymptotes
- Able to trace the curve for given algebraic expression.

5.2 Singular points

A singular point of an algebraic curve is a point where the curve has "nasty" behavior such as a cusp or a point of self-intersection *or more specifically*, a point on the curve at which the curve behaves an unusual behavior is called singular points. A cusp is a point at which two branches of a curve meet such that the tangents of each branch are equal. The plot shown in Figure 1 is the semi cubical parabola curve $x^3 - y^2 = 0$, which has a cusp at the origin.

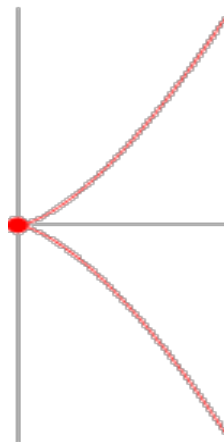

Figure 1: semi cubical parabola curve $x^3 - y^2 = 0$, which has a cusp at the origin.

There are two types of singular points:

- (1) **Point of inflection:** Inflexion is a point on a continuous plane curve at which the curve changes from being concave (concave downward) to convex (concave upward), or vice versa. Simply, Inflection points are the points of the curve where the curvature changes its sign. Figure 2 shows a point of inflection for the curve $y = x^3$.

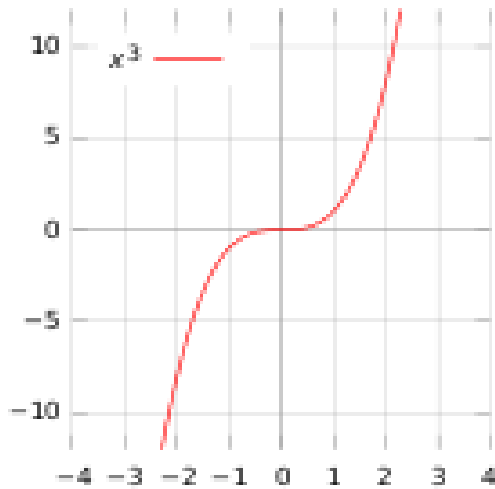
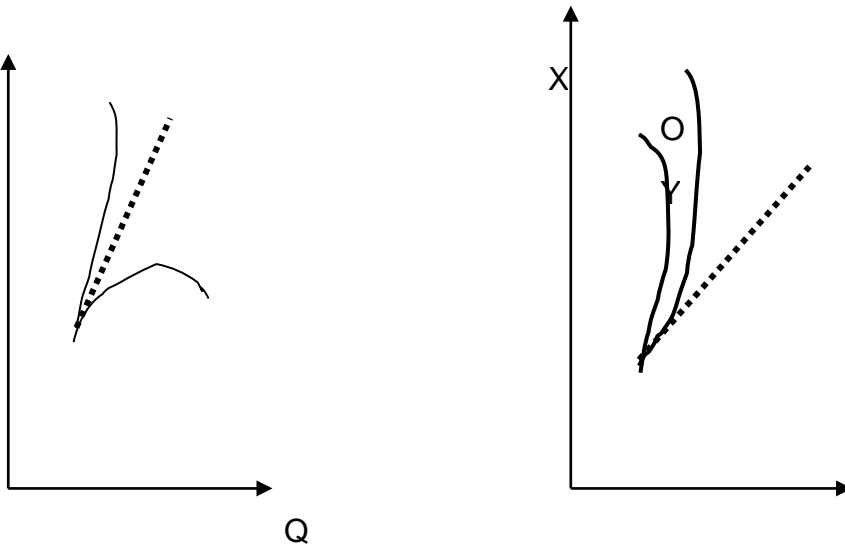

Figure 2: Plot of $y = x^3$ with an inflection point at $(0,0)$, which is also a stationary point.

(2) **Multiple points:** A Point on the curve through which more than one branch of the curve pass is called *Multiple Point*. A point on the curve through which two branches of the curve pass is called *Double Point*. A Point on the curve through three branches of the curve pass is called *Triple Point*. Similarly, if a point on the curve through which n branch of the curve passes is called *Multiple Point of n^{th} order*.



4. Node

In simple words; a double point P on a curve is called a *Node* if *two real branches of a curve pass through P* and two tangents at which are real and different. Thus the point P shown in Figure 6. is a Node.

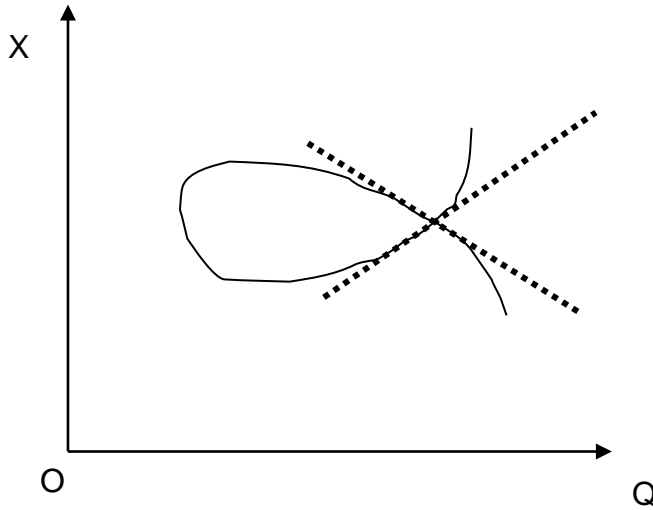

Figure 5

Example 1: Find the nature of the origin of the curve

$$a^4 y^2 = x^4 (x^2 - a^2)$$

Solution: We observe that the curve passes through the origin and

$$y = \pm \frac{x^2}{a^2} \sqrt{x^2 - a^2}$$

Therefore the values of y are imaginary whether $x > 0$ or $x < 0$ & when x is small then origin is a conjugate point on the curve. Further

$$\frac{dy}{dx} = \pm \left[\frac{2x}{a^2} \sqrt{x^2 - a^2} + \frac{x^2}{a^2} \frac{x}{\sqrt{x^2 - a^2}} \right]$$

Therefore $\frac{dy}{dx} = 0$ at $(0, 0)$, and so the tangent at $(0, 0)$ is

$y - 0 = 0(x - 0)$ or $y = 0$ which is real. Then the tangent may be real at a conjugate point.

5.5 Species of cusps

If the curve lies entirely on **one side of the normal** then the cusp is called a **single cusp** and if the curve lies on **both sides of the normal** it is called **double cusp** (Figure 7). Therefore, we have following types of cusps:

- (a) Single cusp of first species
- (b) Single cusp of second species
- (c) Double cusp of first species
- (d) Double cusp of second species

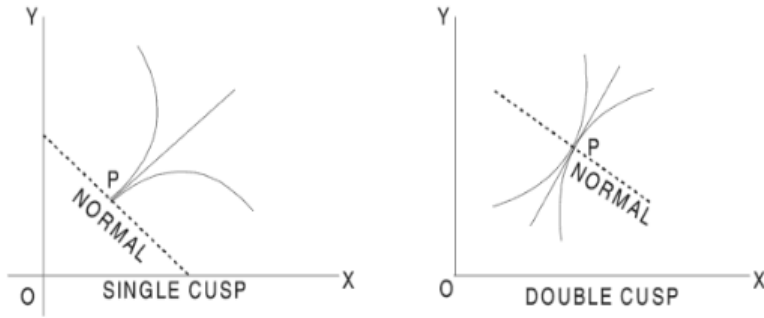

Figure 7

If the two branches of the curve at cusp lie on opposite sides of the common tangent then cusp is of first species, also known as keratoid cusp (Figure 8).

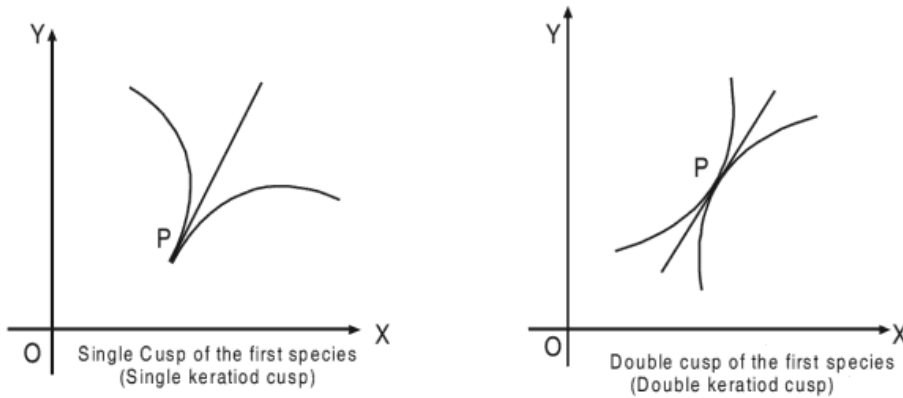

Figure 8: First species of cusp

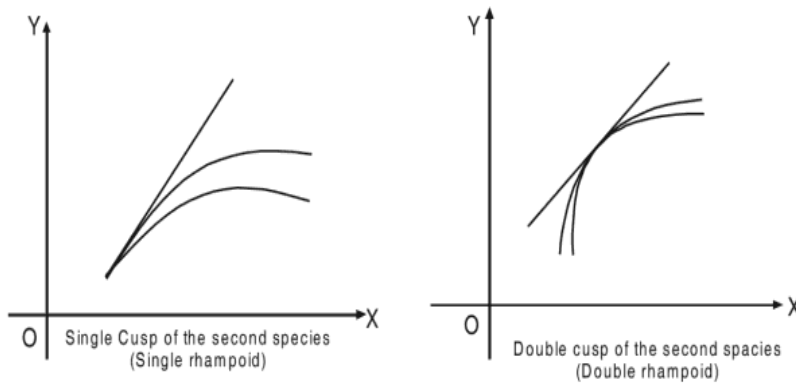

Figure 9: Second species of cusp

If the two branches of the curve at cusp lie on same sides of the common tangent then cusp is of second species, also known as rhampoid cusp (Figure 9).

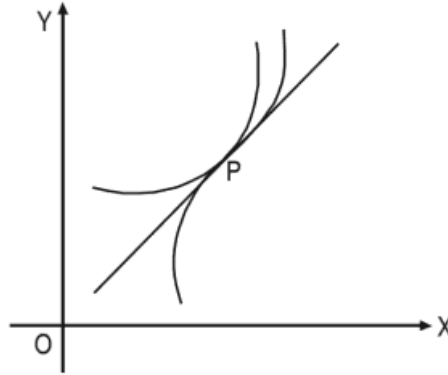

Figure 10: double cusp with change of species

At a double cusp, if species change for the two sides of the cusp, then double cusp is called a point of *osculinflexion* (Figure 10).

5.6 Nature of the cusp at the origin

If the origin is a cusp i.e. the two branches through the double point are real and have coincident tangents. Then the equation of the curve must be of the form:

$$(ax + by)^2 + \text{terms of third degree and higher degree} = 0 \quad \dots\dots\dots (1)$$

Therefore the common tangent at the origin is

$$ax + by = 0 \quad \dots\dots\dots (2)$$

Let p be the length of perpendicular from any point (x, y) on (1) to the line $ax + by = 0$ Then

$$p = \frac{ax+by}{\sqrt{a^2+b^2}}$$

which is proportional to $ax + by$

So we take $p = ax + by$ or $y = \frac{p-ax}{b}$

Putting y in curve we get a relation between p and x . Since p is small so the terms having power of p above second degree will be neglected and so we get a quadratic equation.

$$Ap^2 + Bp + C = 0 \text{ where } A, B, C \quad \dots\dots\dots(3)$$

are function of x

if p_1 & p_2 be the roots of equation (3)

Then $p_1 p_2 = \frac{C}{A} \quad \dots\dots\dots(4)$

So we have the following cases:

Case 1: If for all values of x such that $x < p$ where p is given by (3). The values of p are imaginary so the origin will be a conjugate point.

Case 2: If the values of p in case 1 are real then there will be double cusp at the origin.

Case 3: If the values of p depend on the sign of x there will be single cusp at the origin.

Case 4: If p is real for numerically small values of x , $p_1 p_2 > 0$ then p_1, p_2 will be of the same sign and so there will be a cusp of second species. And if $p_1 p_2 < 0$ and p_1, p_2 are of opposite sign and therefore there will be a cusp of first species.

Example 1: Show that the curve $x^3 + x^2 y = a y^2$ has a single cusp of the first species .

Solution: The curve may be written as

$$a y^2 - x^2 y - x^3 = 0 \quad \dots\dots\dots (1)$$

Equating to zero the terms of lowest degree in (1), the tangents at the origin are given by $y^2 = 0$ or $y = 0$ & $y = 0$

Therefore origin is either a cusp or a conjugate point .

$$\text{From (1) } y = \frac{x^2 \pm \sqrt{x^4 + 4ax^3}}{2a}$$

For smaller value of x ($x \neq 0$); $x^4 + 4ax^3$ has the same sign as of $4ax^3$ which is positive

when $x > 0$ and negative when $x < 0$. Therefore when $x > 0$ then y has two

real values which are positive and negative and when $x < 0$ then y is imaginary.

Hence there is a single cusp of the first species at the origin.

5.7 A necessary condition for the existence of the double points on a curve

Let $f(x, y) = 0$ be the equation of the curve. On transferring the origin to the point (h, k) the equation of the curve becomes

$$f(x + h, y + k) = 0$$

Expanding by Taylor's theorem

$$\begin{aligned} f(x + h, y + k) &= f(h, k) + \left\{ x \frac{\partial f}{\partial x} + y \frac{\partial f}{\partial y} \right\} (h, k) + \\ &\frac{1}{2!} \left\{ x^2 \frac{\partial^2 f}{\partial x^2} + 2xy \frac{\partial^2 f}{\partial x^2 \partial y} + y^2 \frac{\partial^2 f}{\partial y^2} \right\} (h, k) + \dots \\ &\dots\dots\dots (1) \end{aligned}$$

Now in order that the new origin may be a double point the constant term and the terms of the first degree must be absent in equation (1) & so we must have.

$$\frac{\partial f}{\partial x} = 0, \frac{\partial f}{\partial y} = 0, f(x, y) = 0$$

If these conditions are satisfied then tangents at new origin are given by

$$x^2 \cdot \frac{\partial^2 f}{\partial x^2} + 2xy \cdot \frac{\partial^2 f}{\partial x \partial y} + y^2 \cdot \frac{\partial^2 f}{\partial y^2} = 0 \text{ at } (h, k)$$

Therefore in general a double point will be a node, cusp or conjugate point according as

$$\left(\frac{\partial^2 y}{\partial x^2}\right)^2 >, =, < \left(\frac{\partial^2 y}{\partial x^2}\right) \left(\frac{\partial^2 y}{\partial y^2}\right)$$

Example 1: Show that the curve

$$x^3 + 2x^2 + 2xy - y^2 + 5x - 2y = 0$$

has a single cusp & first species at the point (-1, -2)

Solution: let $f(x, y) = x^3 + 2x^2 + 2xy - y^2 + 5x - 2y = 0$

$$\text{Then } \frac{\partial f}{\partial x} = 3x^2 + 4x + 2y + 5 \dots\dots\dots (1)$$

$$\frac{\partial f}{\partial y} = 2x - 2y - 2 \dots\dots\dots (2)$$

$$\text{For double point; } \frac{\partial f}{\partial x} = 0 \text{ \& } \frac{\partial f}{\partial y} = 0$$

$$\therefore 3x^2 + 4x + 2y + 5 = 0$$

$$\text{\& } 2x - 2y - 2 = 0 \text{ or } y = x - 1$$

Solving these equation we get $x = -1, -1$ & $y = -2$ & so (-1, -2) in the double point. Because this point also satisfy the equation of the given curve we new shift the origin to the point (-1, -2) and therefore putting $x = X - 1$ & $Y - 2$ the equation of the curve because

$$(X - 1)^3 + 2(X - 1)^2(X - 1)(X - 2) - (Y - 2)^2 + 5(X - 1) - 2(Y - 2) = 0$$

$$\text{Or } X^3 - X^2 + 2XY - Y^2 = 0 \text{ or } (Y - X)^2 = X^3 \dots\dots\dots (3)$$

Equating to zero the lowest degree terms in equation and the tangents at the new origin (-1, -2) are given by $(Y - X)^2 = 0$ e. i $Y - X = 0, Y - X = 0$ which are coincident tangents at the new origin (-1, -2) and therefore at point (-1, -2) may be a cusp or a conjugate point.

Now considering the tangent $Y - X = 0$, putting $Y - X = p$ in (3) we get

$$p^2 = X^3 \dots\dots\dots (4)$$

Then for very small value of the $X > 0$ the value of p are real and of opposite sign and for $X < 0$ the value of p are imaginary & so the point $(-1, -2)$ is a single cusp of first species for the given curve.

Example 2: Show that the point $(2, 1)$ is a node for the curve $(x - 2)^2 = y(y - 1)^2$

Solution: Let $f(x, y) = (x - 2)^2 - y(y - 1)^2 = 0$

$$\therefore \frac{\partial f}{\partial x} = 2(x - 2) \dots \dots \dots (1) \quad \text{and} \quad \frac{\partial f}{\partial y} = -(y - 1)^2 - 2y(y - 1) \dots \dots \dots (2)$$

$$\text{For the double point } \frac{\partial f}{\partial x} = 0 \quad \& \quad \frac{\partial f}{\partial y} = 0$$

\therefore from (1) we get $x = 2$ & from (2)

$$-(y - 1)\{(y - 1) + 2y\} = 0$$

$$\text{Or} \quad y = 1, \frac{1}{3}$$

\therefore The double point may be $(2, 1)$ & $(2, \frac{1}{3})$

But only $(2, 1)$ lies on the given curve and so $(2, 1)$ is the only double point.

We now shift the origin to the point $(2, 1)$ & so putting $x = X + 2$ & $y = Y + 1$ in the curve we get

$$X^2 = (Y + 1)^2 \cdot Y^2 \dots \dots \dots (3)$$

Equating to zero the lowest degree terms in equation (2) the tangents at the new origin $(2, 1)$ are given by

$$Y = X^2 \quad \text{or} \quad Y = \pm X$$

So the two tangents are real and distinct hence double point is a node .

Check Your progress

Write down the equation of the tangents at origin for the following curve

$$(1) \quad x^4 + 3x^3y + 2xy - y^2 = 0$$

$$(2) \quad x^3 + 3xy + 7x^2 = 0$$

2. show that the origin is a node , a cusp or a cuspate point on the curve

$$y^2 - ax^2 - bx^3 = 0$$

According or $a > 0$, $a = 0$ or $a < 0$

3. Find the position and nature of double points in the

curve

$$x^4 + 4y^3 + 12y^2 - 8x^2 + 16 = 0$$

4. find the position and nature of double points on the curve

$$a^4y^2 = x^4(2x^2 - 3a^2)$$

5.8 Asymptotes

Consider the curves which are extended to infinity and consider a tangent to some point on the curve. If the point of contact is allowed to tend to infinity then tangent may tend to a definite straight line. This straight line is called asymptotes of the curves.

“Thus an asymptote is a straight line at a finite distance from the origin to which the tangent to the curve tends when the points of contact tends to infinity”

5.8.1 The (oblique) asymptotes of the general algebraic curves

Let equation of the curve be

$$\begin{aligned} & a_0y^n + a_1y^{n-1}x + a_2y^{n-2}x^2 + \dots + a_{n-1}yx^{n-1} + a_nx^n \\ & + b_1y^{n-1} + b_2y^{n-2}x + \dots + b_{n-1}yx^{n-2} + b_nx^{n-1} \\ & c_2y^{n-2} + \dots = 0 \end{aligned} \quad \dots\dots\dots(1)$$

Or

$$x^n f_n \left[\frac{y}{x} \right] + x^{n-1} f_{n-1} \left[\frac{y}{x} \right] + \dots\dots\dots = 0 \quad (2)$$

where $f_r \left[\frac{y}{x} \right]$ is an expression of the r^{th} degree is $\left[\frac{y}{x} \right]$

Dividing by x^n we get

$$f_n \left[\frac{y}{x} \right] + \frac{1}{x} f_{n-1} \left[\frac{y}{x} \right] + \frac{1}{x^2} f_{n-2} \left[\frac{y}{x} \right] + \dots\dots\dots = 0 \quad (3)$$

Now excluding the case in (3) in which is $\lim_{x \rightarrow \infty} \frac{y}{x}$ is infinite, equation (3)

$$\text{gives } f_n(m) = 0 \quad (4)$$

Where $m = \lim_{x \rightarrow \infty} \left[\frac{y}{x} \right]$

From equation (4) we get the value of m in the asymptote $y = mx + c$.

Note: - Since equation (4) is of degree n in m so there will be n values of m corresponding to the n branch of the curve (1). Some value of m may be imaginary or coincident.

Now differentiating (3), we get

$$\left\{ f'_n \left[\frac{y}{x} \right] + \frac{1}{x} f'_{n-1} \left[\frac{y}{x} \right] + \dots \right\} \left(\frac{y'x - y}{x^2} \right) - \frac{1}{x^2} f_{n-1} \left[\frac{y}{x} \right] - \frac{2}{x^3} f_{n-2} \left[\frac{y}{x} \right] \dots = 0$$

Now multiplying this by x^2 and taking limit $x \rightarrow \infty$ and $\lim_{x \rightarrow \infty} (y'x - y) = -c$

We get $cf'_n(m) + f_{n-1}(m) = 0$ (5)

(since if $y = mx + c$ is an asymptote to the curve $y = f(x)$ then $m = \lim_{x \rightarrow \infty} \left(\frac{y}{x} \right)$ and $c = \lim_{x \rightarrow \infty} (y - mx)$)

where $\lim_{x \rightarrow \infty} (y'x - y) = -c$

From (5) we get value of c for different value of m obtaining from (4).

Hence the asymptotes are $y = mx + c$ where m is a root of (4) and the corresponding value of c is obtained from (5).

5.82. Simple methods to find the asymptotes of a given curve

Method 1:

1. Put $mx + c$ for y in the equation of the curve and arrange it in the descending power of x.
2. Equating the coefficient of two highest power of x to zero find m and c (i.e. the coefficient of x^n and x^{n-1})
3. Put these values of m and c in $y = mx + c$ to get the equation of the asymptotes

4. If for some value of m the coefficient of x^{n-1} is zero then we find c from the equation obtained by equating to zero the coefficient of the next highest power i.e. the coefficient of x^{n-2} .

OR

Method 2:

- Put $x = 1$ and $y = m$ in the n^{th} degree term and get $f_m(m)$. Put $f_m(m) = 0$ and solve it for m . Let $m_1, m_2, m_3, \dots, m_n$ be its roots
- Find $f_{n-1}(m)$ by putting $x = 1$ and $y = m$ in the terms of degree $(n - 1)$ and find the value of c by putting $m = m_1, m_2, m_3, \dots, m_n$ in the formula $c = -\frac{f_{n-1}(m)}{f'_n(m)}$

Then the asymptotes are $y = m_1x + c_1, y = m_2x + c_2$ etc.

Example 1: Find the asymptotes of the curve

$$x^3 + y^3 - 3axy = 0$$

Putting $x = 1$ and $y = m$ in the third degree terms and second degree terms separately we get, $f_3(m) = 1 + m^3$ and $f_2(m) = -3am$

We solve

$$f_m = 0 \text{ i.e. } 1 + m^3 = 0$$

$$\text{or } (1 + m)(1 - m + m^2) = 0$$

Which gives $m = -1$ as the only real root next to find c we use the formulæ

$$c = -\frac{f_2(m)}{f'_3(m)} = \frac{-3am}{3m^2} = \frac{a}{m}$$

Now putting $m = -1$ we get, $c = -a$

∴ equation of the asymptotes is

$$y = mx + c \text{ or } y = -x - a$$

$$\text{or } x + y + a = 0$$

Example 2: Find the asymptotes of

$$4x^3 - x^2y - 4xy^2 + y^3 + 3x^2 + 2xy - y^2 - 7 = 0$$

Putting $x = 1$ and $y = m$ in the third degree terms and second degree terms separately, we get

$$f_3(m) = 4 - m - 4m^2 + m^3$$

$$\text{and } f_2(m) = 3 + 2m - m^2$$

We now solve $f_3(m) = 4 - m - 4m^2 + m^3 = 0$

$$(4 - m)(1 - m^2) = 0$$

$$\text{or } m = 1, -1, 4$$

$$\text{Also } f'_3(m) = -1 - 8m + 3m^2$$

$$\therefore c = -\frac{f_2(m)}{f'_3(m)} = \frac{3 + 2m - m^2}{1 + 8m - 3m^2}$$

$$\text{Now putting } m = 1 \text{ we get, } c = \frac{2}{3}$$

$$\text{And when } m = -1 \text{ we get, } c = 0$$

$$\text{And } m = 4 \text{ we get, } c = \frac{1}{3}$$

Thus the asymptotes are $y = mx + c$

$$y = x + \frac{2}{3}, y = -x, \text{ and } y = 4x + \frac{1}{3}$$

Example 3: Find the asymptotes of

$$y^3 - 3x^2y + xy^2 - 3x^3 + 2y^2 + 2xy + 4x + 5y + 6 = 0$$

Putting $x = 1$ and $y = m$ in the third degree terms and second degree terms separately, we get

$$f_3(m) = m^3 + m^2 - 3m - 3$$

$$\therefore f'_3(m) = 3m^2 + 2m - 3$$

$$\text{and } f_2(m) = 2(m + m^2)$$

Now putting $f_3(m) = 0$ we get

$$m^3 + m^2 - 3m - 3 = 0$$

$$(m + 1)(m^2 - 3) = 0$$

$$m = -1, m = \pm\sqrt{3}$$

Next to find c , we get

$$c = -\frac{f_2(m)}{f'_3(m)} = \frac{-2(m+m^2)}{3m^2+2m-3}$$

Now putting $m = -1$ we get, $c = -2$

And when $m = \sqrt{3}$ we get, $c = -1$

And $m = -\sqrt{3}$ we get, $c = -1$

Thus the asymptotes are $y = mx + c$

$$y = x - 2, \quad y = \sqrt{3}x - 1, \quad \text{and} \quad y = -\sqrt{3}x - 1$$

Example 4: Show that the curve

$$y^3 = x^2 + 3x \text{ has no asymptotes}$$

The curve is $y^3 - x^2 - 3x = 0$

Putting $x = 1$ and $y = m$ in the third degree terms and second degree terms separately, we get

$$f_3(m) = m^3$$

$$\text{and } f_2(m) = -1 \text{ so } f'_3(m) = 3m^2$$

We now solve $f_3(m) = 0$

$$m^3 = 0 \Rightarrow m = 0, 0, 0, 1$$

$$\therefore c = -\frac{f_2(m)}{f'_3(m)} = \frac{-1}{3m^2}$$

which is infinity for $m = 0$.

Therefore the given curve has no asymptotes.

5.8.3 Two parallel asymptotes

Suppose that the equation $f_n(m) = 0$ gives two equal values of m . These values of m makes $f_n(m) = 0$ and $f_{m-1}(m) \neq 0$ then $f'_n(m) = 0$ and $f_{m-1}(m) \neq 0$

$$c = -\frac{f_{n-1}(m)}{f'_n(m)}$$

and so we get the value of c to be infinity so the asymptotes does not exist. Therefore for the existence of the asymptotes for this value of m it is necessary that

$f_{n-1}(m) = 0$ then the equation

$$cf'_n(m) + f_{n-1}(m) = 0$$

from which c reduces to identity

$$0.c + 0 = 0$$

and so we can not find the value of c . To find the value of c in the case we equate to zero the efficient of x^{n-2} in the equation (3) of section 5.8.1 of topic. And we get on differentiating it twice and multiplying by suitable power of x and taking the limit

$$\frac{1}{2}c^2 f''_n(m) + cf'_{n-1}(m) + f_{n-2}(m) = 0$$

which quadratic in c and so we get two values of c . Let them be c_1 and c_2 corresponding to the repeated value of m . Therefore the asymptotes will be $y = mx + c_1$ and $y = mx + c_2$ which are parallel.

Example 1: Find the asymptotes of

$$y^3 + x^2y + 2xy^2 - y + 1 = 0$$

Putting $x = 1$ and $y = m$ in the third degree term and second degree term separately. We get,

$$f_3(m) = m^3 + 2m^2 + m$$

$$\text{and } f_2(m) = 0 \dots \dots \dots (1)$$

$$\therefore f'_3(m) = 3m^2 + 4m + 1$$

We now solve

$$f_3(m) = 0 \text{ i.e. } m^3 + 2m^2 + m = 0$$

$$\text{i.e. } m(m^3 + 2m + 1) = 0 \Rightarrow m(m+1)^2 = 0$$

So we get $m = 0, -1, -1$

The value of c is given by $c = -\frac{f_2(m)}{f'_3(m)} = 0$ (since $f_2(m) = 0$)

and when $m=0$ we get $c=0$ therefore the asymptotes is ($y = mx+c$) $\therefore y=0$

when $m = -1$ we get $c = -0/0$

(from $c = -f_2(m)/f_1(m)$)

which is indeterminate form. In this case c is obtained from the equation

$$\frac{c^2}{2} f_3''(m) + cf_2'(m) + f_1(m) = 0 \dots\dots(2)$$

Putting $x = 1$ and $y = m$ in the first degree term of the equation of the curve, we get

$$f_1(m) = -m \text{ and also } f_3'''(m) = 6m + 4$$

From (1) and $f_2''(m) = 0$

therefore for $m = -1$, c is given by

$$\frac{c^2}{2}(6m + 4) + c \cdot 0 - m = 0 \quad \text{from(2)}$$

$$\text{or } (3m + 2)c^2 - m = 0$$

Putting $m = -1$, we get

$$-c^2 + 1 = 0 \text{ or } c = \pm 1$$

So the asymptotes are

$y = -x + 1$ and $y = -x - 1$ which are parallel asymptotes

5.8.4 Asymptotes Parallel to X-axis

The general equation of the curve of degree (equation (1) of 12.1) can be arranged according to the power of x as

$$a_n x^n + (a_{n-1}y + b_n)x^{n-1} + (a_{n-2}y^2 + b_{n-1}y + c_n)x^{n-2} + \dots\dots = 0 \dots\dots\dots(1)$$

Putting $x = 1$ and $y = m$ in the highest degree term of the equation, we get

$$a_n + a_{n-1}m + a_{n-2}m^2 + \dots\dots = 0 \quad \dots\dots(2)$$

therefore if $a_n = 0$ then $m = 0$ will be the root of the equation (2) and so the corresponding asymptotes is $y = c \dots\dots\dots(3)$

where c is obtained by putting $y = 0$ in (1) and equating to zero the coefficient of x^{n-1} and so the value of c in (3) is obtained by

$$a_{n-1} \cdot c + b_n = 0 \dots\dots\dots(4)$$

Now putting the value of c from equation (4) in (3) we get the same as eliminating c from (4) and (3).

Hence asymptote is $a_{n-1}y + b_n = 0$

Which is the same as equating to zero the coefficient of x^{n-1} in (1).

Note:-Hence the asymptotes parallel to the axis of X can be obtained by equating to zero the coefficient of the highest power of x . (if it is not a constant). Similarly the asymptotes parallel to the axis of Y are obtained

by equating to zero the coefficient of the highest power of y . (if it is not a constant).

Example 1: - Find the asymptotes parallel to the coordinate axes of the curve

$$x^2(x-y)^2 + a^2(x^2 - y^2) - a^2xy = 0$$

equating to zero the coefficient of the highest power of y (i.e. if y^2) the asymptotes parallel to y axis are given by

$$x^2 - a^2 = 0 \quad \text{or} \quad x = \pm a$$

Since the coefficient of the highest power of x (i.e. if x^4) is a constant and so there are no asymptotes parallel to X - axis .

5.9 Curve Tracing

The objective of curve tracing is to find the approximate shape of a curve without the labor of plotting a large number of points.

Cartesian Equations: If the Cartesian Equation is given, you can invariably *solve it either for y , or for x , or for r* (in terms of θ in the last case), otherwise the curve will be too difficult for you to trace.

Only curves in which we can solve for y need be considered here because, if the equation cannot be solved for y , but can be solved for x , we have only to regard y as the independent variable. If the equation can be solved for r , the rules for tracing polar curves will apply.

5.9.1 Procedure

1. **Symmetry:** Notice if the curve is symmetrical about any line, by applying the following rules, whose truth is evident:
 - (i) If the powers of y which occur in the equation are all even, the curve is symmetrical about the axis of x .
 - (ii) If the powers of x are all even, the curve is symmetrical about the axis of y . A curve might, of course, be symmetrical about both axes.
 - (iii) If x and y can be interchanged without altering the equation, the curve is symmetrical about the line $y = x$.
 - (iv) If on changing the signs of x and y both, the equation to the curve is not altered, the curve after being turned through two right angles will coincide with its old trace. (This is generally denoted by saying that there is symmetry in opposite quadrants.)
2. **At the Origin:** Notice if the curve passes through the origin. If it does, write down the equation of the tangent, or tangents, there. If

the origin is a singular point, find its nature. Remember that the higher powers of x in the expression for y can be neglected when tracing the curve for (numerically) very small values of x .

- 3. Solve for y :** Solve for y (which, by supposition, is possible). Choose any convenient value of x for which y is finite, and if possible zero (generally $x = 0$ is convenient). Consider how y will vary as x increases and then tends to infinity, paying particular attention to those values of x for which $y = 0$, or $\rightarrow\infty$.

If the curve is symmetrical about the x -axis, or if there is symmetry in opposite quadrants, only positive values of y need be considered. The curve for negative values of y can be drawn from symmetry.

- 4. Consider All Values of x :** Starting from the chosen value of x , repeat the above procedure as x decrease and then $\rightarrow -\infty$.

Of course, if the curve is symmetrical about the y -axis, it can be drawn for negative values of x by symmetry, so such values of x need not be considered afresh.

- 5. Imaginary Values of y :** In the above procedure, if y is found to be imaginary for a certain range of values of x , say for values of x between a and b , it would mean that the curve does not exist in the region bounded by the lines $x = a, x = b$.

- 6. Asymptotes:** If the curve extends to infinity, and there is approximately a linear relation between x and y for numerically large values of x , there is an oblique asymptote. This should now be found, and also, if necessary, it should be investigated on which side of it the curve lies.

Note: When x and y are numerically very large, only the highest powers of these may be retained to find the approximate shape of the curve. The presence of asymptotes parallel to the axes and their positions can be found as given in section asymptotes..

- 7. Special Points:** Find the coordinates of a few points on the curve if it appears necessary.

For example, if y is 0 at $x = 0$, and against at $x = b$, and is positive for the intermediate values, it might be desirable to find the maximum (greatest) value of y between a and b . At the point for which y is maximum, the tangent (as is evident from geometry) will be horizontal and so dy/dx will be zero. Hence this points can be easily found. Even if the maximum value is not found, it would be desirable to find the value of y when x is equal to, say, $\frac{1}{2}(a + b)$.

8. **Inflexion:** If the curve as traced appears to possess a point of inflexion, that point can be more accurately located by putting d^2y/dx^2 or d^2x/dy^2 equal to zero and solving the equation thus obtained.
9. One should remember that merely a knowledge of symmetry, asymptotes, tangents at the origin, points of inflexion, double points, and the coordinates of a few other points will never enable him to trace a curve. His difficulties regarding curve-tracing will vanish only if he realizes that we have solved for y and expressed it as a function of x whose values can be easily found for every value of x , and that his task is to save time by picking out the most important values of x (say those at which y is a minimum or a maximum, or is zero or infinity, or just begins to be imaginary or ceases to be so): then, by noticing how y varies (i.e. increases or diminishes) as x is made to vary continuously from $-\infty$ to ∞ , the curve is easily traced. We need not begin from $-\infty$ (if that is inconvenient) provided later we consider the remaining values also of x .

NOTE: An equation of the second degree in x and y gives merely one of the conic sections, and so can be traced.

Example 1: Trace the curve $y^2(a+x) = x^2(3a-x)$

Solution:

- (i) This curve is symmetrical about the axis of x .
- (ii) The curve passes through the origin. The tangents there are given by $y^2 = 3x^2$, which represents two non-coincident straight lines. Hence we may expect a node at the origin.
- (iii) Solving for y , and considering only the positive value,

$$y = x\sqrt{\frac{3a-x}{a+x}} \text{ -----(1)}$$

If $x = 0$, then $y = 0$. When x is positive and small, y is real. We notice also that as

$$\frac{3a-x}{a+x} < \frac{3a}{a} \text{ i.e. } < 3, \text{ y is less than } x\sqrt{3}. \text{ Hence the curve lies below}$$

the tangent $y = x\sqrt{3}$ for small positive value of x . As x goes on increasing, y next becomes zero at $x = 3a$. When x is greater than $3a$, the expression under the radical sign is negative and so y is imaginary. To trace the curve more exactly we find the following also:

When $x = a, y = a$; and when $x = 2a, y = 2a/\sqrt{3} = 1.2a$ nearly.

Also, if we transfer the origin to $(3a,0)$ the equation to the curve will become $y^2(4a+x) = (x+3a)^2(-x)$, and the tangent at the new origin will be $x=0$, obtained by equating to zero the terms of the lowest degree.

Hence the curve must be of the shape shown in fig.1

- (iv) If x is negative and numerically small, (1) shows that y is real. Also, for values of x under consideration, $3a - x > 3(a + x)$, . Hence y is numerically greater than $-(\sqrt{3})x$, i.e. the curve lies above the tangent $y = -(\sqrt{3})x$, in the second quadrant. As we move still more to the left $a + x$ gets still smaller and so y gets larger. In fact as $x \rightarrow -a$ from the right of the point $x = -a$, the positive value of y tends to $+\infty$. $x + a = 0$ is evidently as asymptote.

When $x < -a$, the quantity under the radical is negative and so y is imaginary.

Therefore, taking symmetry into account, the curve is shown below:

The curve of equation $y^2(a+x) = x^2(3a-x)$ is shown next:

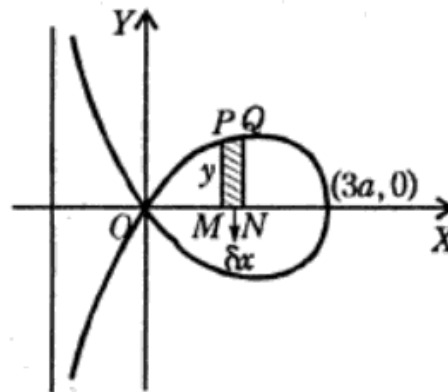

Fig. 1

Example 2: Trace the curve $y^2(x^2+y^2) - 4x(x^2+2y^2) + 16x^2 = 0$

Solution:

- (i) The curve is symmetrical about the x -axis.
- (ii) The curve passes through the origin, the tangents there being $x^2 = 0$, which represents two coincident straight lines. Hence we may expect a cusp there.

- (iii) The equation to the curve is a quadratic in y^2 , and can be written as $y^4 + y^2(x^2 - 8x) - 4x^3 + 16x^2 = 0$. Hence
- $$y^2 = \frac{1}{2}\{8x - x^2 \pm \sqrt{x^4 - 16x^3 + 64x^2 + 16x^3 - 64x^3}\}$$
- $$= \frac{1}{2}\{8x - x^2 \pm x^2\} = 4x \text{ or } 4x - x^2$$

Hence the curve consists of the parabola $y^2 = 4x$ and the circle $x^2 + y^2 = 4x$.

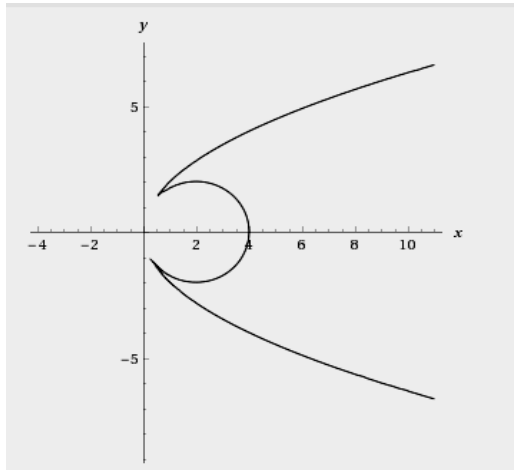

Fig. 2

Example 3: Trace the curve $x = (y - 1)(y - 2)(y - 3)$.

Solution:

- (i) The curve is not symmetrical about the axes or about $x = y$.
- (ii) It does not pass through the origin.
- (iii) It is difficult to solve it for y . But it is already solved for x . Hence we take y as the independent variable. When $y = 0$, $x = -6$.

When $y = 1$, $x = 0$. Between $y = 0$ and $y = 1$, x is negative as then all the three factors are negative.

When y lies between 1 and 2, x is positive as one factor is positive and two are negative x next becomes zero at $y = 2$. Between $y = 2$ and $y = 3$, x is negative.

x next becomes zero at $y = 3$.

When $y > 3$, x is positive. As $y \rightarrow \infty$, $x \rightarrow \infty$. For very large valued of y , x is approximately equal to y^3 . Hence there is no linear asymptote for this branch.

- (iv) When y is negative, x is negative. As $y \rightarrow -\infty$, $x \rightarrow -\infty$. As in the last paragraph, we can see that there is no linear asymptote for this branch also.

- (v) When $y = 1\frac{1}{2}, x = \frac{3}{8}$; when $y = 2\frac{1}{2}, x = -\frac{3}{8}$. Hence the shape of the curve is as shown in fig.3

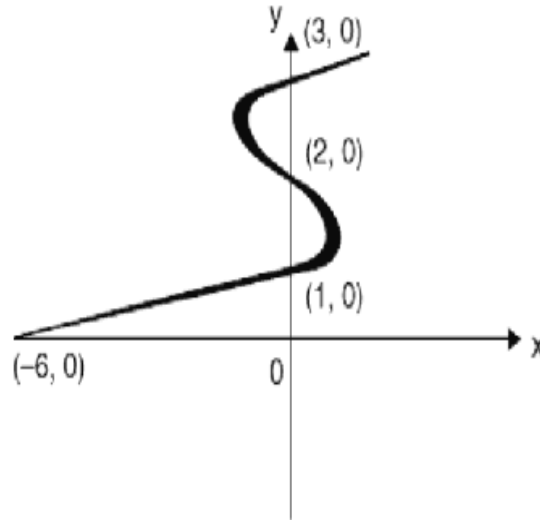

Fig. 3

If we like we can also find where the tangent is parallel to the y -axis. At these points $dx/dy = 0$, i.e. $(y - 1)(y - 2) + (y - 1)(y - 3) + (y - 2)(y - 3) = 0$

Or $3y^2 - 12y + 11 = 0$ i.e. the tangent is parallel to the y -axis where

$$y = \frac{6 \pm \sqrt{36 - 33}}{3} = 2 \pm \sqrt{3}/3 = 2.6 \text{ and } 1.4, \text{ nearly.}$$

We can now find the values of x for these values of y , and thus find the shape of the curve a little more exactly.

5.10 Summary

In this Unit, we studied singular points and their types and regular points. Also, double points and their classification is described for better understanding. Cusp and their species are discussed in detail with several examples. Nature of cusp and necessary condition for the existence of the double points on a curve is described with examples. An important section is devoted on asymptotes and method to find the asymptotes of a given curve. The curve tracing procedure is also discussed in detail with many examples.

5.11 Terminal Questions

1. Trace the curve

- (i) $y^2(a + x) = x^2(3a - x)$
- (ii) $x = (y - 1)(y - 2)(y - 3)$
- (iii) $ay^2 = x^2(a - x)$
- (iv) $ay^2 = x^2(x - a)$

2. Prove that the curves

$$ay^2 = (x - a)^2(x - b) \text{ has}$$

- (i) a conjugate point at $x=a$ if $a < b$
- (ii) a node at $x=a$ if $a > b$ &
- (iii) cusp at $x=a$ if $a=b$.

3. Trace the curve

I. $\gamma = a \cos 3\theta$

II. $\gamma = \theta(\theta + \sin\theta)$

- 4. Trace the curve $y^2(a^2 + x^2) = x^2(a^2 - x^2)$ and show that the origin is a node.
- 5. Trace the curve $a^4y^2 = x^5(2a - x)$

RIL-146

UGMM-103/132

UNIT-6

AREA UNDER A CURVE

Structure

- 6.1 Introduction
 - Objective
- 6.2 Area in Cartesian form
- 6.3 Area in Polar form
- 6.4 Area Bounded by a closed curve
- 6.5 Length of a plane curve
 - 6.5.1 Cartesian form
 - 6.5.2 Parametric form
 - 6.5.3 Polar form
- 6.6 Summary
- 6.7 Terminal Questions

6.1 Introduction

In this section we shall show how the area under a curve can be calculated when the equation of the curve is given in the

- (i) Cartesian form
- (ii) Polar form
- (iii) Parametric form

Some curves may have a simple equation in one form, but complicated ones in others. So, once we have considered all these forms, we can choose an appropriate form for a given curve, and then integrate it accordingly. Let us consider these forms of equations one by one.

Objective:

After reading this unit you should be able to :

- Recognize area of the curve in Cartesian form
- Recognize area of the curve in Polar form and in parametric form

6.2 Area in Cartesian form

We shall quickly recall what we studied in earlier. Let $y = f(x)$ define a continuous function of x on the closed interval $[a, b]$. For simplicity, we make the assumption that $f(x)$ is positive for $x \in [a, b]$. Let R be the plane region in Fig. 1(a) bounded by the graphs of the four equations: $y = f(x)$, $y = 0$, $x = a$ and $x = b$.

We divide the region R into n thin strips by lines perpendicular to the x -axis through the end points $x = a$ and $x = b$, and through many intermediate points which we indicate by x_1, x_2, \dots, x_{n-1} . Such a subdivision, as we have already seen a partition P_n of the interval $[a, b]$ is indicated briefly by writing. $P_n = [a = x_0 < x_1 < x_2 < \dots < x_{n-1} < x_n = b]$

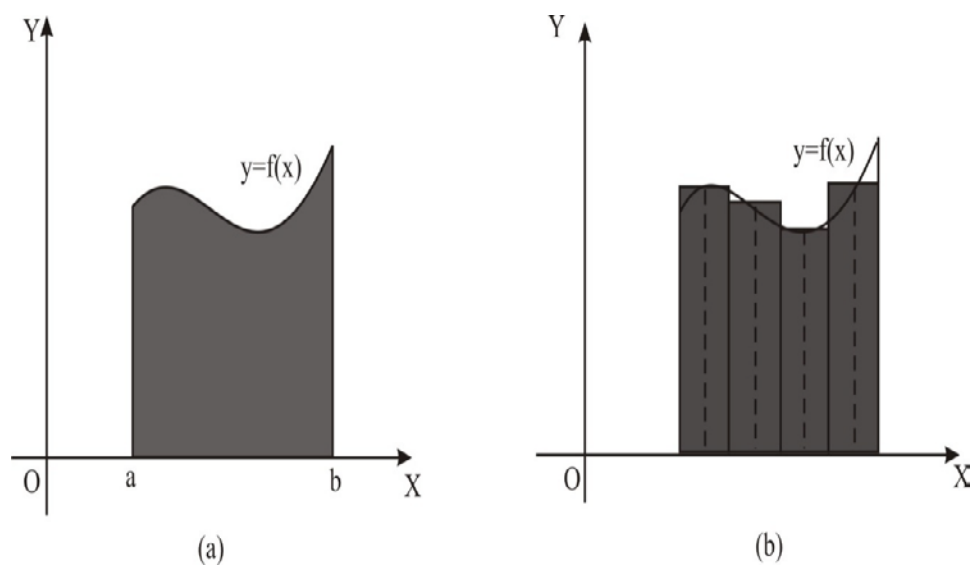
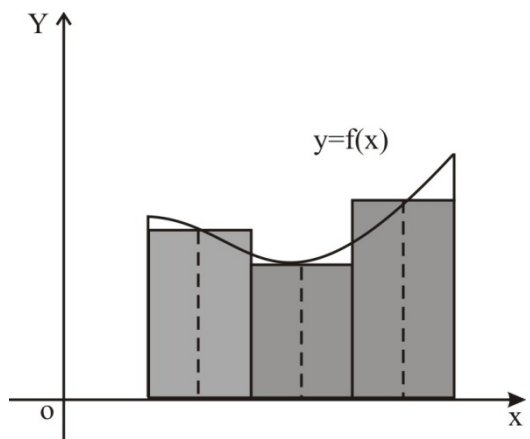

Fig. 1

We write $\Delta x_i = x_i - x_{i-1}$ for $i = 1, 2, \dots, n$, and take the set of n points on x -axis. $T_n = \{t_1, t_2, \dots, t_{n-1}, t_n\}$, such that $x_{i-1} \leq t_i \leq x_i$ for $i = 1, 2, \dots, n$. We now construct the n rectangles (Fig. 1 (b)) whose bases are then n sub-intervals $[x_{i-1}, x_i]$, $i = 1, 2, \dots, n$ induced by the partition P_n , and whose altitudes are $f(t_1), f(t_2), \dots, f(t_1), \dots, f(t_{n-1}), f(t_n)$. The

sum $\sum_{i=1}^n f(t_i) \Delta x_i$ of the areas of these n rectangles will be an

approximation to the “area of R ”. Notice (Fig. 2(a) and (b)) that if we increases the number of sub-intervals, and decrease the length of each sub-interval, we obtained a closer approximation of the “area of R ”



(a)

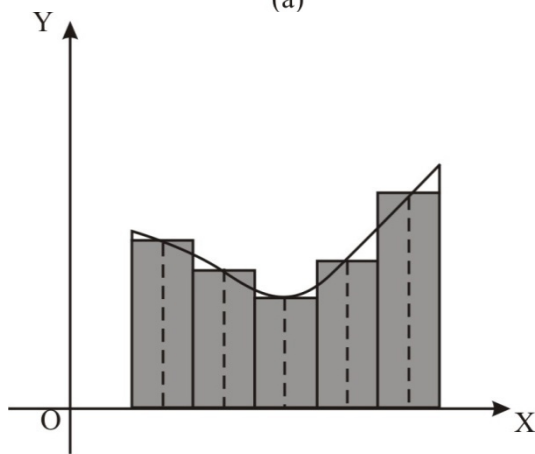

(b)

Fig. 2

Thus, we have

Definition 1: Let f be a real valued function continuous on $[a, b]$, and let $f(x) \geq 0 \forall x \in [a, b]$. If the limit of $\sum_{i=1}^n f(t_i) \Delta x_i$ exists as the lengths of the sub-intervals, $\Delta x_i \rightarrow 0$, then that limit is the area A of the region R .

$$A = \lim_{\substack{\Delta x_i \rightarrow 0 \\ i=1, 2, \dots, n}} \sum_{i=1}^n f(t_i) \Delta x_i$$

Compare this definition with that of a definite integral given in Block 3. Over there we had seen that the definite integral.

$\int_a^b f(x) dx$ is the common limit of $\sum_{i=1}^n m_i \Delta x_i$ and $\sum_{i=1}^n M_i \Delta x_i$ as the $\Delta x_i \rightarrow 0$.

Now since $m_i \leq f(t_i) \leq M_i \forall i$, we have

$$\sum_{i=1}^n m_i \Delta x_i \leq \sum_{i=1}^n f(t_i) \Delta x_i \leq \sum_{i=1}^n M_i \Delta x_i$$

Hence if the limit of each of these as $\Delta x_i \rightarrow 0$ exists, then by the Sandwich Theorem

$$A = \lim_{\substack{\Delta x_i \rightarrow 0 \\ i=1, 2, \dots, n}} \sum_{i=1}^n m_i \Delta x_i \leq \lim_{\substack{\Delta x_i \rightarrow 0 \\ i=1, 2, \dots, n}} \sum_{i=1}^n f(t_i) \Delta x \leq \lim_{\substack{\Delta x_i \rightarrow 0 \\ i=1, 2, \dots, n}} \sum_{i=1}^n M_i \Delta x_i$$

Now, if $\int_a^b f(x) dx$ exists, then the first and the third limits here are equal,

and therefore we get $A = \int_a^b f(x) dx$. _____ (1)

The equality in (1) is a consequence of the definitions of the area of R and the definite integral $A = \int_a^b f(x) dx$. Since $f(x)$ is assumed to be continuous on the interval $[a, b]$, the integral in (1) exists, and hence yields the area of the region R under consideration. From the Interval Union Property of definite integrals, we have

$$\int_a^b f(x) dx = \int_a^c f(x) dx + \int_c^b f(x) dx, a \leq c \leq b \dots \dots \dots (2)$$

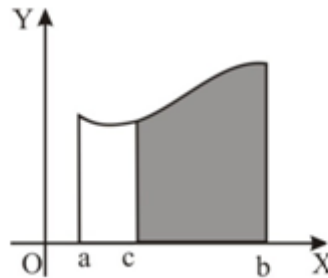

Fig. 3

This means if A_a^c, A_c^b, A_a^b denote the areas under the graph of $y = f(x)$ above the x-axis from a to c , from c to b and from a to b , respectively, (Fig. 3) then, if c is in between a and b , then we have $A_a^c + A_c^b = A_a^b$ _____ (3)

If we define $A_a^a = 0, A_b^b = 0$, then above equation is true for $c = a$ and $c = b$ too.

Till now, we have assumed the function $f(x)$ to be positive in the interval $[a, b]$. In general, function $f(x)$ may assume both positive and negative values in the interval $[a, b]$. To cover such a case, we introduce the convention about signed areas.

The area is taken to be positive above the x-axis as we go from left to right, and negative if we go from right to left. The function $f(x)$ may be defined beyond the interval $[a, b]$ also. In that (3) is true even if c is

beyond b, Since according to our convention of signed areas, A_c^b will turn out to be a negative quantity (Fig. 4).

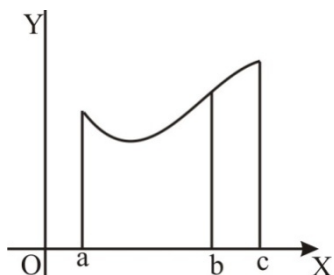

Fig. 4

Thus, $A_a^c = A_a^b + A_b^c = A_a^b - A_b^c$, Or $A_a^b + A_b^c = A_a^c$

Not, if $f(x) \leq 0$ for all x in some interval $[a, b]$ then by applying the definition of “area of R” to the function $-f(x)$, we get the area

$$A = -\int_a^b f(x)dx$$

If we do not take the negative sign, the value of the areas will come out to be negative, since $f(x)$ is negative for all $x \in [a, b]$. To avoid a “negative” area, we follow this convention. Thus, if $f(x) \leq 0$ for $x \in [a, b]$ (Fig. 5), then the area between the ordinates $x = a$ and $x = b$ will be

$$A = -\int_a^b f(x)dx$$

The following example will illustrate how our knowledge of evaluating definite integral can be used to calculate certain areas.

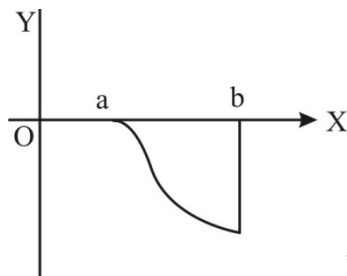

Fig. 5

Example 1: Suppose we want to find the area of the region bounded by the curve $y = 16 - x^2$, the x-axis and the ordinates $x = 3$, $x = -3$. The region R, whose area is to be found, is shown in Fig. 6.

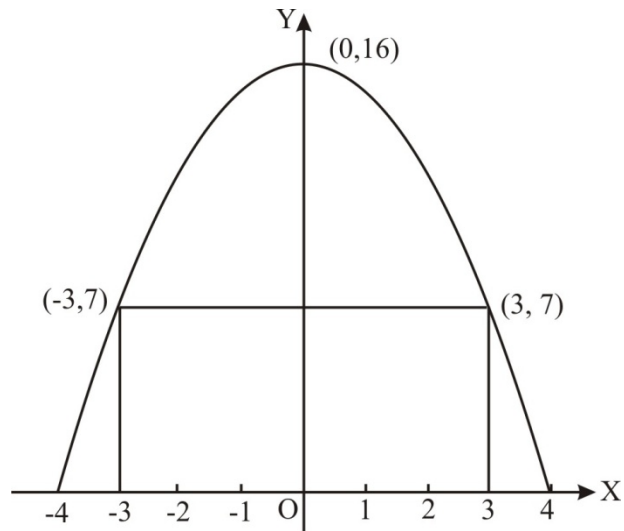

Fig.6

The area A of the region R is given by

$$A = -\int_{-3}^3 (16 - x^2) dx = \left[16x - \frac{x^3}{3} \right]_{-3}^3 = 78$$

Example 2: Consider the region R in Fig. 7.

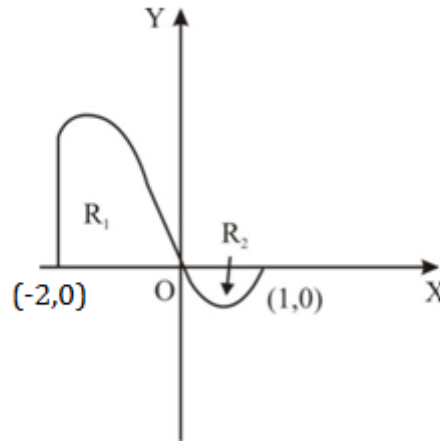

Fig.7

R is composed of two parts, the region R_1 and the region R_2 . We have
 $\text{Area } R = \text{Area } R_1 + \text{Area } R_2$

The region R_1 is bounded above the x -axis by the graph of $y = x^3 + x^2 - 2x$, $x = -2$ and $x = 0$. Hence, $\text{Area } R_1 = \int_{-2}^0 (x^3 + x^2 - 2x) dx =$

$$\left[\frac{x^4}{4} + \frac{x^3}{3} - x^2 \right]_{-2}^1 = \frac{8}{3}$$

The region R_2 is bounded below the x-axis by the graph of $y = x^3 + x^2 - 2x$,

$$2x, x = 0 \text{ and } x = 1. \text{ Area } R_2 = -\int_0^1 (x^3 + x^2 - 2x) dx = -\left[\frac{x^4}{4} + \frac{x^3}{3} - x^2 \right]_0^1 = \frac{5}{12}$$

$$\text{Therefore, Area } R = \frac{8}{3} + \frac{5}{12} = \frac{37}{12}$$

Area $R_2 = \int_0^1 f(x) dx$. If we calculate $R_2 = \int_{-2}^1 f(x) dx$, it will amount to calculating

$\int_{-2}^1 f(x) dx + \int_0^1 f(x) dx = \text{area } R_1 - \text{area } R_2$, which would be a wrong estimate of area R.

Example 3: Let us find the area of the smaller region lying above the x-axis and included between the circle $x^2 + y^2 = 2x$ and the parabola $y^2 = x$ in the first quadrant.

Solution: On solving the equation $x^2 + y^2 = 2x$ and $y^2 = x$ simultaneously, we get $(0, 0)$, $(1, 1)$, $(1, -1)$ as the points of intersection of the given curves. We have to find the area of the region R bounded OAPBO (Fig. 8).

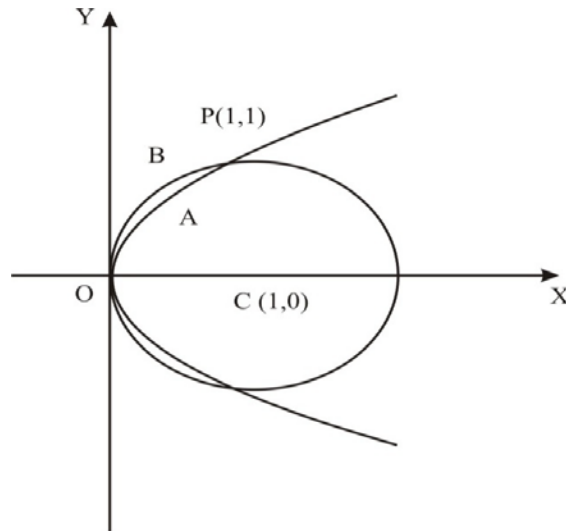

Fig. 8

From the figure we see that area of region OAPBO

= area of region OCPBO – area of region OCPAO

$$= \int_0^1 \sqrt{2x - x^2} dx - \int_0^1 \sqrt{x} dx$$

RIL-146 Now, $\int_0^1 \sqrt{2x - x^2} dx = \int_0^1 \sqrt{1 - (1-x)^2} dx = \int_{\pi/2}^0 \cos \theta (-\cos \theta) d\theta$, on putting $1 - x = \sin \theta$

$$= \int_{\pi/2}^0 -\cos^2 \theta d\theta = \int_0^{\pi/2} \cos^2 \theta d\theta = \frac{\pi}{4}. \text{ Also } \int_0^1 \sqrt{x} dx = \frac{2}{3}$$

Therefore, the required area = $\left(\frac{\pi}{4} - \frac{2}{3}\right)$

In this sub-section we have derived a formula (Formula (1)) to find the area under a curve when the equation of the curve is given in the cartesian form. With slight modifications we can use this formula to find the area when the curve is described by a pair of parametric equations.

We shall take a look at curves given by parametric equation is little late. But first, let us consider the curve given by a polar equation.

6.3 Area in Polar form

Sometimes the cartesian equation of a curve is very complicated, but its polar equation is not so. Cardioids and spirals are examples of such curves. For these curves it is much simpler to work with their polar equation rather than with the cartesian ones. In this sub section we shall see how to find the area under a curve if the equation of the curve is given in the polar form. Here we shall try to approximate the given area through the areas of a series of circular sectors. These circular sectors will perform the same function here as rectangles did in cartesian coordinates.

Let $r = f(\theta)$ determine a continuous curve between the rays $\theta = \alpha$ and $\theta = \beta$, ($\beta - \alpha \leq 2\pi$). We want to find the area $A(R)$ of the shaded region R in Fig 9(a)

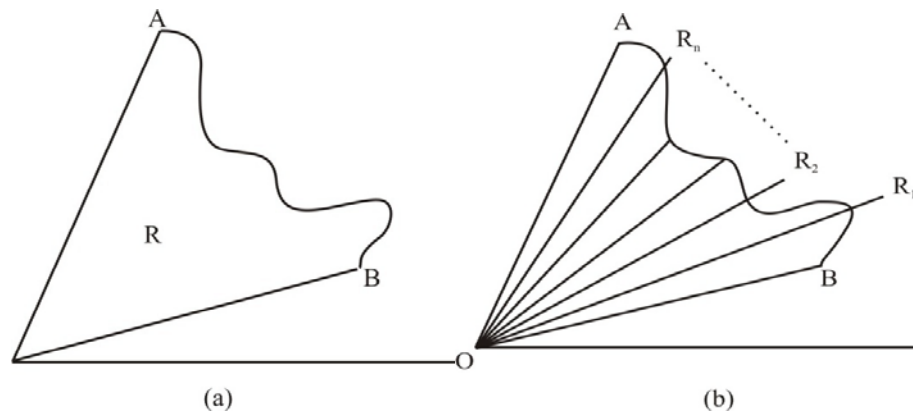

Fig. 9

Imagine that the angle AOB is divided into n equal parts, each measuring $\Delta\theta$,

Then $\Delta\theta = \frac{\beta - \alpha}{n}$. This amounts to slicing R into n smaller regions,

R_1, R_2, \dots, R_n , as shown in Fig. 9(b), Then clearly

$$A(R) = A(R_1) + A(R_2) + \dots + A(R_n) = \sum_{i=1}^n A(R_i)$$

Now let us take the i^{th} slice R_i , and try to approximate its area. Look at Fig. 10. Suppose f attains its minimum and maximum values on $[\theta_{i-1}, \theta_i]$ at u_i and v_i .

$$\text{Then } \frac{1}{2} [f(u_i)]^2 \Delta\theta \leq A(R_i) \leq \frac{1}{2} [f(v_i)]^2 \Delta\theta.$$

$$\text{From this we get } \sum_{i=1}^n \frac{1}{2} [f(u_i)]^2 \Delta\theta \leq \sum_{i=1}^n A(R_i) \leq \sum_{i=1}^n \frac{1}{2} [f(v_i)]^2 \Delta\theta$$

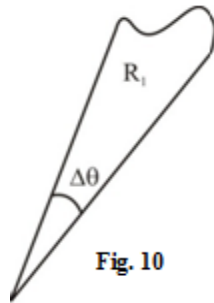

Fig. 10

The first and the third sums in this inequality are equal to $\int_{\alpha}^{\beta} \frac{1}{2} [f(\theta)]^2 d\theta$.

Therefore, by applying the sandwich theorem as $\Delta\theta \rightarrow 0$, we get

$$A(R) = \frac{1}{2} \int_{\alpha}^{\beta} [f(\theta)]^2 d\theta = \frac{1}{2} \int_{\alpha}^{\beta} r^2 d\theta$$

We shall illustrate the use of this formula through some examples. Study them carefully, so that you can do the exercises that follows late.

Example 4: Suppose we want to find the area enclosed by the cardioids $r = a(1 - \cos \theta)$. We have $r = 0$ for $\theta = 0$ and $r = 2a$ for $\theta = \pi$.

Since $\cos \theta = \cos(-\theta)$, the cardioids is symmetrical about the initial lines AOX (Fig. 11).

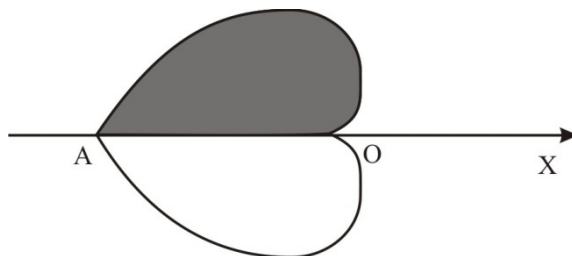

Fig.11

Hence the requirement area A, which is twice the area of the shaded region in Fig. 11, is given by $A = 2 \int_0^{\pi} \frac{1}{2} r^2 d\theta = 4x^2 \int_0^{\pi} \sin^4 \frac{\theta}{2} d\theta$, since

$$\cos \theta = \cos^2 \frac{\theta}{2} - \sin^2 \frac{\theta}{2}$$

$$= 8a^2 \int_0^{\pi/2} \sin^4 \phi d\phi, \text{ where } \phi = \frac{\theta}{2} = 8a^2 \frac{3}{4} \frac{1}{2} \frac{\pi}{4} \text{ applying the reduction}$$

$$\text{formula} = \frac{3}{2} a^2 \pi$$

In the case of some Cartesian equations of higher degree it is often convenient to change the equation into polar form. The following example gives one such situation.

Example 5 : To find the area of the loop of the curve. $x^5 + y^5 = 5ax^2y^2$.

We change the given equation into a polar equation by the transformation

$$x = r \cos \theta, \text{ and } y = r \sin \theta, \text{ then we obtain } r = \frac{5a \cos^2 \theta \sin^2 \theta}{\cos^5 \theta + \sin^5 \theta}$$

Which yields $r = 0$ for $\theta = 0$ and $\theta = \pi/2$. Hence, area A of the loop is that of a sectorial area bounded by the curve and radius vectors $\theta = 0$ and $\theta = \pi/2$, that is, the area swept out by the radius vector as it moves from $\theta = 0$ to $\theta = \pi/2$. See Fig. 12

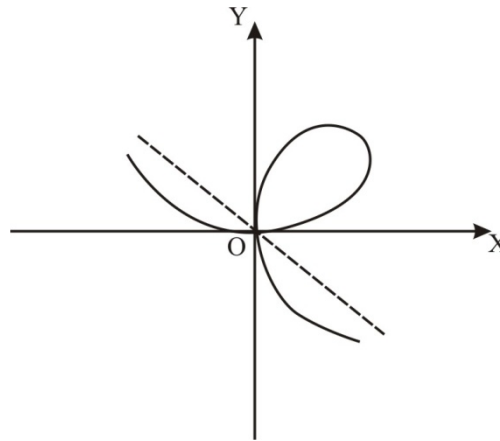

Fig.12

$$\text{Thus, } A = \frac{1}{2} \int_0^{\pi/2} \frac{25a^2 \cos^4 \theta \sin^4 \theta}{(\cos^5 \theta + \sin^5 \theta)^2} d\theta = \frac{25}{2} a^2 \int_0^{\pi/2} \frac{\tan^4 \theta \sec^2 \theta}{(1 + \tan^5 \theta)} d\theta$$

$$= \frac{5}{2} a^2 \int_1^{\infty} \frac{dt}{t^2}, \text{ where } t = 1 + \tan^5 \theta = \frac{5}{2} a^2 [-1/t]_1^{\infty} = \frac{5}{2} a^2$$

Check your progress

- (1) Find the area under the curve $y = \sin x$ between $x = 0$ and $x = \pi$.
- (2) Find the area bounded by the x -axis, the curve $y = e^x$, and the ordinate $x = 1$ and $x = 2$.
- (3) Find the area of the region bounded by the curve $y = 5x - x^2$, $x = 0$, $x = 5$ and lying above the x -axis.
- (4) Find the area cut off from the parabola $y^2 = 4ax$ by its latus rectum, $x = a$.
- (5) Find the area between the parabola $y^2 = 4ax$ and the chord $y = mx$.
- (6) Find the area of a loop of the curve $r = a \sin 3\theta$.
- (7) Find the area enclosed by the curve $r = a \cos 2\theta$ and the radius vectors.
- (8) Find the area of the region outside the circle $r = 2$ and inside the lemniscates $r^2 = 8 \cos 2\theta$. [hint: First find the points of intersection. Then the required area = the area under the lemniscates – the area under the circle].

Check your progress

- (9) Find the area of the curve $x = a(3 \sin \theta - \sin^3 \theta)$, $y = a \cos^3 \theta$, $0 \leq \theta \leq 2\pi$.
- (10) Find the area enclosed by the curve $x = a \cos \theta + b \sin \theta + c$
 $Y = a' \cos \theta + b' \sin \theta + c'$, where $0 \leq \theta \leq 2\pi$
- (11) Find the area of one of the loops of the curve $x = a \sin 2t$, $y = a \sin t$.
(Hint : first two values of t which give the same values of x and y , and take these as the limits of integration)

6.4 Area Bounded by a Closed Curve

Now we shall turn our attention to closed curves whose equations are given in the parametric form. Let the parametric equations. $x = \phi(t)$, $y = \Psi(t)$, $t \in [\alpha, \beta]$,

Where $\phi(\alpha) = \phi(\beta)$, and $\Psi(\alpha) = \Psi(\beta)$, represent a plane closed curve (Fig. 13).

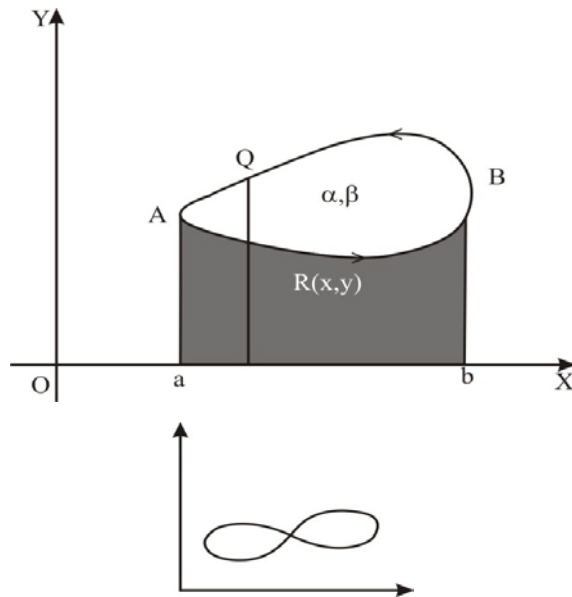

Fig. 13

This means that as the parameter t increases from a value α to a value β , the point $P(x, y)$ describes the curve completely in the counter clockwise sense. Since the curve is closed, the points on it corresponding to the value β is the same as the point corresponding to the value α . This is reflected by the conditions $\phi(\alpha) = \phi(\beta)$ and $\Psi(\alpha) = \Psi(\beta)$.

Suppose further that the curve is cut at most in two points of every line drawn parallel to the x or y -axis. We also assume that the functions ϕ and Ψ are differentiable, and that the derivatives ϕ' and Ψ' do not vanish α and β i.e., at R we have $\phi(\alpha) = \phi(\beta)$ and $\Psi(\alpha) = \Psi(\beta)$.

Now suppose A is a point on the curve which has the least x -coordinate, say a . Similarly, suppose B is a point on the curve which has the greatest x -coordinate, say b . thus the lines $x = a$ and $x = b$ touch the curve in points A and B , respectively. Further let t_1 and t_2 be the values of t that correspond to A and B , respectively. Then. $\alpha < t_2 < t_1 < \beta$

Let a point Q correspond to $t = t_3$ such that $t_2 < t_3 < t_1$. The area of the region enclosed is $S = S_1 - S_2$ and S_1 are the areas under the arcs AQB and ARB , respectively. The minus is because one is clockwise and other is anti-clockwise (see Fig. 13). Hence.

$$S_2 = \int_a^b y \, dx \quad \text{and} \quad S_1 = \int_a^b y \, dx$$

Now, as a point $P(x, y)$ moves from B to A along BQA , the value of the parameter increases from t_2 to t_1 . Therefore $\int_a^b y \, dx = \int_{t_2}^{t_1} y \frac{dx}{dt} dt$. Hence

$$S_2 = - \int_{t_2}^{-t_1} y \frac{dx}{dt} dt$$

Now the movement of P from A to B along ARB , can be viewed in two parts. From A to R and from R to B . As P moves from A to R , the value of the parameter increases from t_1 to β , and as P moves from R to B , t increase from α to t_2 .

$$\text{Therefore, } S_1 = - \int_a^b y \, dx = \int_{t_1}^{\beta} y \frac{dx}{dt} dt + \int_{\alpha}^{t_2} y \frac{dx}{dt} dt$$

$$\text{Thus, we have } S_1 = - \int_a^b y \, dx - \int_a^b y \, dx = S_2 - S_1$$

(AQB) (ARB)

$$= -0 \int_a^b y \frac{d}{x} dt - \int_{t_1}^b y \frac{dx}{dt} dt - \int_a^b y \frac{dx}{dt} = - \int_a^b y \frac{dx}{dt} dt$$

_____ (i)

Note that the negative sign is due to the direction in which we go round the curve as marked by arrows in Fig. 13

Similarly, by drawing tangents to the curve that are parallel to the x-axis, it can be shown that $S = \int_{\alpha}^{\beta} x \frac{dy}{dt} dt$. _____ (ii)

From (i) and (ii), we get

$$2S = \int_{\alpha}^{\beta} \left(x \frac{dy}{dt} - y \frac{dx}{dt} \right) dt$$

Hence, the area enclosed is

$$S = \frac{1}{2} \int_{\alpha}^{\beta} (x dy - y dx)$$

_____ (5)

We can use any of the formulas (i), (ii) and (5) above for calculating S. But in many cases you will find that formula (5) is more convenient because of its symmetry.

Example 6: Let us find the area of the asteroid $x = a \cos^3 t, y = \sin^3 t, 0 \leq t \leq 2\pi$

The region bounded by the astroied is shown in Fig. 14.

The area A of the region is given by

$$A = \frac{1}{2} \int_0^{2\pi} \left(x \frac{dy}{dt} - y \frac{dx}{dt} \right) dt = \frac{1}{2} \int_0^{2\pi} a \cos^3 t$$

$$= (3b \sin^2 t \cos t) - b \sin^3 (-3 a \cos^2 t \sin t) dt = \frac{3ab}{2} \int_0^{2\pi} \cos^2 \sin^2 t dt$$

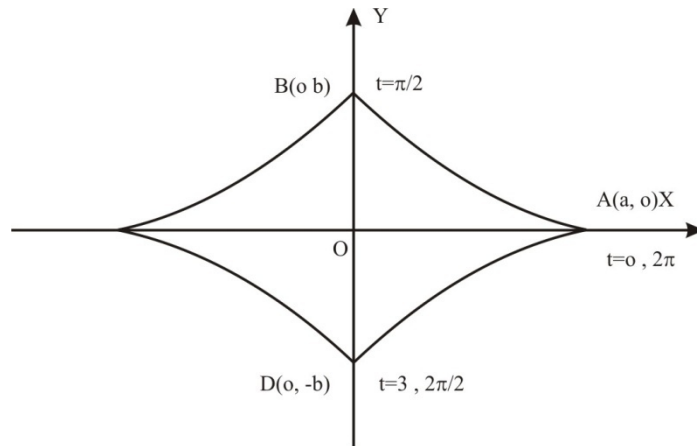

Fig.14

$$\int_0^{2a} f(x) dx = 2 \int_0^a f(x) dx, \text{ if } f(2a - x) = f(x).$$

Here $\cos^2(2\pi - t) \sin^2(2\pi - t) = \cos^2 t \sin^2 t$. Hence

$$\int_0^{2\pi} \cos^2 t \sin^2 t dt = 2 \int_0^{\pi} \cos^2 t \sin^2 t dt. \text{ Therefore, } A=3ab$$

$$\int_0^{\pi/2} \cos^2 t \sin^2 t dt.$$

Now, by a similar argument we can say that

$$A = 6ab \int_0^{\pi/2} \cos^2 t \sin^2 t dt, = \frac{3\pi ab}{8}, \text{ by using the reduction formula.}$$

Check your progress

(12) Find the area of the curve $x = a(3 \sin \theta - \sin^3 \theta)$, $y = a \cos^3 \theta$, $0 \leq \theta \leq 2\pi$.

(13) Find the area enclosed by the curve $x = a \cos \theta + b \sin \theta + c$

$$Y = a' \cos \theta + b' \sin \theta + c', \text{ where } 0 \leq \theta \leq 2\pi$$

(14) Find the area of one of the loops of the curve $x = a \sin 2t$, $y = a \sin t$.

(Hint : first two values of t which give the same values of x and y , and take these as the limits of integration)

6.5 Length of A Plane Curve

In this section we shall see how definite integrals can be used to find the lengths of plane curves whose equations are given in the Cartesian, polar or parametric form. A curve whose length can be found is called a rectifiable curve and the process of finding the length of a curve is called rectification. You will see here that to find the length of an arc of a curve, we shall have to integrate an expression which involves not only the given function, but also its derivative. Therefore, to ensure the existence which determines the arc length, we make an assumption that the function defining the curve is derivable, and its derivative is also continuous on the interval of integration.

Let's first consider a curve whose equation is given in the Cartesian form.

6.5.1 Cartesian Form

Let $y = f(x)$ be defined on the interval $[a, b]$. We assume that f is derivable and its derivative f' is continuous. Let us consider a partition P_n of $[a, b]$, given by $P_n = [a = x_0 < x_1 < x_2 < \dots < x_n = b]$

The ordinates $x = a$ and $x = b$ determine the extent of the arc AB of the curve $y = f(x)$. [Fig. 1(a)]. Let $M_i = 1, 2, \dots, n - 1$, be the points in which the lines $x = x_i$ meet the curve. Join the successive points $A, M_1, M_2,$

M_3, \dots, M_{n-1}, B by straight line segments. Here we have approximated the given curve by a series of line segments.

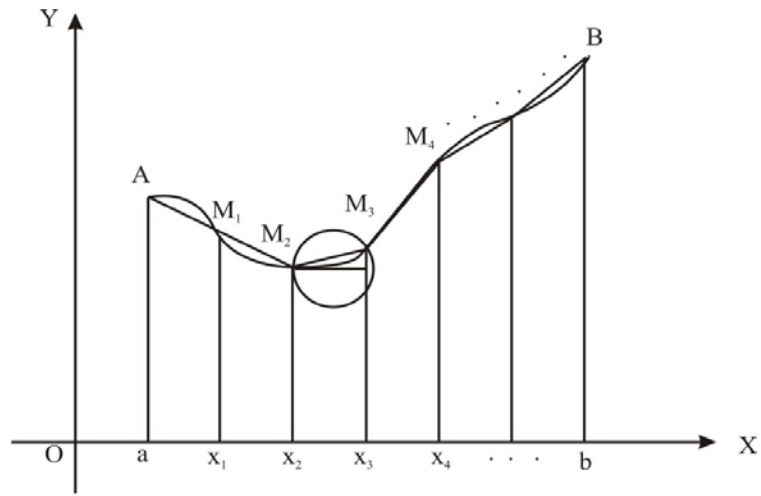

(a)

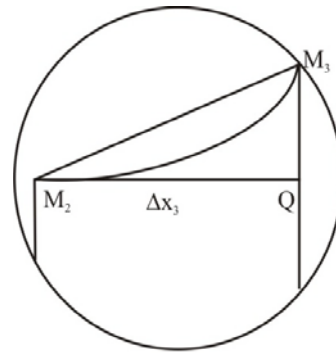

(b)

Fig.1

If we can find the length of each line segment, the total length of this series will give us an approximation to the length of the curve. But how do we find the length of any of these line segments? Take M_2, M_3 , for example (Fig. 1(b) shows an enlargement of the encircled portion in Fig. 1(a). Looking at it we find that

$$M_2M_3 = \sqrt{(\Delta x_3)^2 + (\Delta y_3)^2} . \text{ Where } \Delta x_3 = M_2Q \text{ is the length } (x_3 - x_2),$$

and $\Delta y_3 = M_3Q = f(x_3) - f(x_2) = y_3 - y_2$. In this way we can find the lengths of the chords $AM_1, M_1M_2, \dots, M_{n-1} B$, and take their sum

$$S_n = \sum_{i=1}^n \sqrt{(\Delta x_i)^2 + (\Delta y_i)^2} ,$$

S_n gives an approximation to the length of the arc AB . When the number of division points is increased indefinitely, and the length of each segment tends to zero, we obtained the length of the arc AB as

$$L_A^B = \lim_{n \rightarrow \infty} \sum_{i=1}^n \sqrt{(\Delta x_i)^2 + (\Delta y_i)^2} \quad \text{provided this limit exists. Our} \quad \text{---(1)}$$

assumptions that f is derivable on $[a, b]$, and that f' is continuous. Thus, there exists a point $P_i^*(x_i^*, y_i^*)$ between the points M_{i-1} and M_i on the curve, where the tangent to the curve is parallel to the chord $M_{i-1} M_i$. That is,

$$f'(x_i^*) = \frac{\Delta y_i}{\Delta x_i} \text{ or, } \Delta y_i = f'(x_i^*) \Delta x_i. \text{ Hence we can write (1) as}$$

$$L_B^A = \lim_{n \rightarrow \infty} \sum_{i=1}^n \sqrt{(\Delta x_i)^2 + [f'(x_i^*) \Delta x_i]^2} = \lim_{n \rightarrow \infty} \sum_{i=1}^n \sqrt{1 + [f'(x_i^*)]^2}$$

This is nothing but the definite integral $\int_a^b \sqrt{1 + [f'(x)]^2} dx$ or,

$$L_A^B = \int_a^b \sqrt{1 + \left(\frac{dy}{dx}\right)^2} dx \quad \text{_____ (2)}$$

Remark 1: It is sometimes convenient to express x as a single valued function of y . In this case we interchange the roles of x and y , and get the length

$$L_A^B = \int_c^d 1 + \left(\frac{dx}{dy}\right)^2 dx, \text{ where the limits of integration are with respect to } y. \quad \text{_____ (3)}$$

Note that the length of an arc of a curve is invariant since it does not depend on the choice of coordinates, that is, on the frame of reference. Our assumption that f' is continuous on $[a, b]$ ensure that the integrals in (2) and (3) exist, and their value L_A^B is the length of the curve $y = f(x)$ between the ordinates $x = a$ and $x = b$.

Example 1: Suppose we want to find the length of the arc of the curve $y = \ln x$ intercepted by the ordinates $x = 1$ and $x = 2$. We have drawn the curve $y = \ln x$ in Fig.2

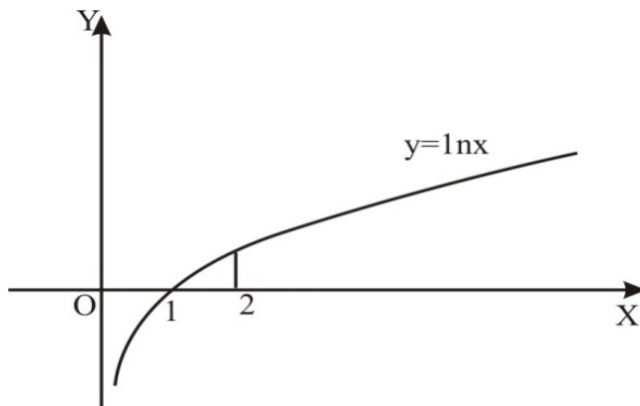

Fig.2

Using (2), the required length L_1^2 is given by $L_1^2 = \int_1^2 \sqrt{1 + \left(\frac{dy}{dx}\right)^2} dx$

$$\int_1^2 \sqrt{\left(1 + \frac{1}{x^2}\right)} dx, \text{ since } \frac{dy}{dx} = \frac{1}{x}$$

If we put $1 + x^2 = t^2$, we get $\frac{dx}{dt} = \frac{t}{x}$, and therefore,

$$\begin{aligned} L_1^2 &= \int_{\sqrt{2}}^{\sqrt{5}} \left(1 + \frac{1}{t^2 - 1}\right) dt = \int_{\sqrt{2}}^{\sqrt{5}} dt + \int_{\sqrt{2}}^{\sqrt{5}} \frac{1}{t^2 - 1} dt = \left[t + \frac{1}{2} \ln \frac{t-1}{t+1} \right]_{\sqrt{2}}^{\sqrt{5}} \\ &= \sqrt{5} - \sqrt{2} + \frac{1}{2} \ln \frac{\sqrt{5}-1}{\sqrt{5}+1} - \frac{1}{2} \ln \frac{\sqrt{2}-1}{\sqrt{2}+1} = \sqrt{5} - \sqrt{2} + \ln \frac{2(\sqrt{2}+1)}{\sqrt{5}+1} \end{aligned}$$

We can also use (3) to solve this example. For this we write the equation $y = \ln x$ as $x = e^y$. The limits $x = 1$ and $x = 2$, then correspond to the limits $y = 0$ and $y = \ln 2$, respectively. Hence, using (3), we obtain

$$\begin{aligned} L_0^{\ln 2} &= \int_0^{\ln 2} \sqrt{1 + e^{2y}} dy = \int_{\sqrt{2}}^{\sqrt{5}} \frac{u^2}{\sqrt{u^2 - 1}} du, \text{ on putting } 1 + e^{2y} = u^2 \\ &= \int_{\sqrt{2}}^{\sqrt{5}} \left(1 + \frac{1}{u^2 - 1}\right) du, = \sqrt{5} - \sqrt{2} + \ln \frac{2(\sqrt{2}+1)}{\sqrt{5}+1} \end{aligned}$$

Check your progress

- (1) find the length of the line $x = 3y$ between the points (3, 1) and (6, 2). Verify your answer by using the distance formula.
- (2) find the length of the curve $y = \ln \sec x$ between $x = 0$ and $x = \pi/2$.
- (3) find the length of the arc of the catenary $y = C \cosh (x/c)$ measured from the vertex (0, c) to any point (x, y) on the catenary.
- (4) Find the length of the semi cubical parabola $ay^2 = x^3$ from the vertex to the point (a, a).
- (5) Show that the length of the arc of the parabola $y^2 = 4ax$ cut off by the line $3y = 8x$ is $a(1 + \ln 2 + 15/16)$.

6.5.2 Parametric Form

Sometimes the equation of a curve cannot be written either in the form $y = f(x)$ or in the form $x = g(y)$. A common example is a circle $x^2 + y^2 = a^2$. In such cases, we try to write the equation of the curve in the parametric form. For example, the above circle can be represented by the pair of equations $x = a \cos t$, $y = a \sin t$. Here, we shall derive a formula to find the length of a curve given by a pair of parametric equations. Let $x = \phi(t)$,

$y = \Psi(t)$, $\alpha \leq t \leq \beta$ be the equation of a curve in parametric form. As in the previous sub section, we assume that the functions ϕ and Ψ are both derivable and have continuous derivatives ϕ' and Ψ' on the interval $[\alpha, \beta]$.

We have $\frac{dx}{dt} = \phi'(t)$, and $\frac{dy}{dt} = \psi'(t)$. Hence, $\frac{dy}{dx} = \frac{\Psi'(t)}{\phi'(t)}$, and

$$\sqrt{1 + \left(\frac{dy}{dx}\right)^2} = \sqrt{1 + \left(\frac{\Psi'(t)}{\phi'(t)}\right)^2}$$

$$\sqrt{1 + \left(\frac{dy}{dx}\right)^2} = \sqrt{1 + \left(\frac{\Psi'(t)}{\phi'(t)}\right)^2} \quad (\text{we assume that } \phi'(t) \neq 0).$$

Now, using (3) we obtain the length $L = \int_{x=\phi(\alpha)}^{x=\phi(\beta)} \sqrt{1 + \left(\frac{dy}{dx}\right)^2} dx$

$$= \int_{t=\alpha}^{t=\beta} \sqrt{[\phi'(t)]^2 + [\psi'(t)]^2} \frac{\phi'(t)}{\phi'(t)} dt. \text{ Thus, } L = \int_{\alpha}^{\beta} \sqrt{[\phi'(t)]^2 + [\psi'(t)]^2} dt$$

Example 2: Let us find the whole length of the curve $\left(\frac{x}{a}\right)^{2/3} + \left(\frac{y}{b}\right)^{2/3} = 1$. By substitutions, you can easily check that $x = a \cos^3 t$, $y = b \sin^3 t$ is the parametric form of the given curve. The curve lies between the lines $x = -\pm a$ and $y = \pm b$ since $-1 \leq \cos t \leq 1$, and $-1 \leq \sin t \leq 1$. The curve is symmetrical about both the axes since its equation remain unchanged if we change the signs of x and y . The value $t = 0$ corresponds to the point $(a, 0)$ and $t = \pi/2$ corresponds to the point $(0, b)$. By applying the curve tracing methods discussed in Unit 9 we can draw this curve (see Fig. 3).

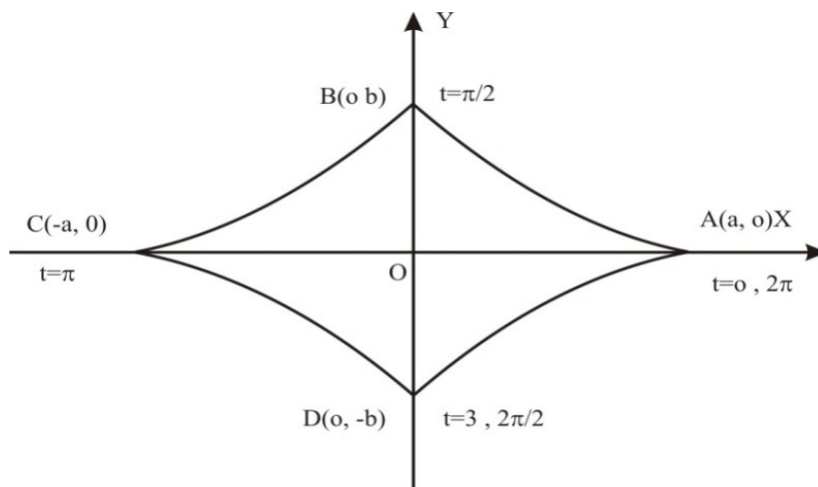

Fig.3

Since the curve is symmetrical about both axes, the total length of the curve is four times its length in the first quadrant.

$$\text{Now, } \frac{dx}{dt} = -3a \cos^2 t \sin t; \frac{dy}{dt} = 3b \sin^2 t \cos t$$

$\left(\frac{dx}{dt}\right)^2 + \left(\frac{dy}{dt}\right)^2 = 9 \sin^2 t \cos^2 t (a^2 \cos^2 t + b^2 \sin^2 t)$ Hence, the length of the curve is

$$L = 4 \int_0^{\pi/3} \sin t \cos t \sqrt{a^2 \cos^2 t + b^2 \sin^2 t} dt = 12 \int_0^{\pi/2} \sin t \cos t \sqrt{a^2 \cos^2 t + b^2 \sin^2 t} dt$$

Putting $u^2 = a^2 \cos^2 t + b^2 \sin^2 t$, we obtain $2u = (2b^2 - 2a^2) \sin t \cos t \frac{dt}{du}$

And the limits $t = 0, t = \pi/2$ correspond to $u = a, u = b$, respectively. Thus, we have

$$= 12 \int_a^b \frac{u^2 du}{b^2 - a^2} = \frac{12}{b^2 - a^2} \left[\frac{u^3}{3} \right]_a^b = \frac{12}{b^2 - a^2} \frac{b^3 - a^3}{3} = \frac{4(a^2 + b^2 + ab)}{a + b}$$

6.5.3 Polar Form

In this sub section we shall consider the case of a curve whose equation is given in the polar form. Let $r = f(\theta)$ determine a curve as θ varies from $\theta = \alpha$ to $\theta = \beta$, i.e., the function f is defined in the interval $[\alpha, \beta]$ (see Fig. 4). As before, we assume that the function f is derivable and its derivative f' is continuous on $[\alpha, \beta]$. This assumption ensures that the curve represented by $r = f(\theta)$ is rectifiable.

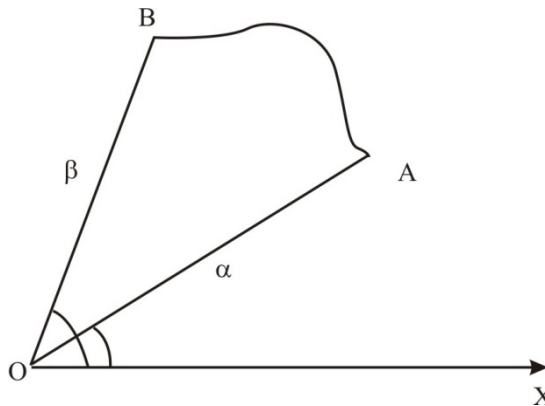

Fig. 4

Transforming the given equation into Cartesian coordinates by taking $x = r \cos \theta$, $y = r \sin \theta$, we obtain $x = f(\theta) \cos \theta$, $y = f(\theta) \sin \theta$.

Now we proceed as in the case of parametric equations, and

$$\text{get, } \sqrt{1 + \left(\frac{dy}{dx}\right)^2} = \frac{\sqrt{\left(\frac{dx}{d\theta}\right)^2 + \left(\frac{dy}{d\theta}\right)^2}}{dx/d\theta}$$

Hence, the length of the arc of the curve $r = f(\theta)$ from $\theta = \alpha$ to $\theta = \beta$ is given by

$$L = \int_{x=f(\alpha)\cos\alpha}^{x=f(\beta)\cos\beta} \sqrt{1 + \left(\frac{dy}{dx}\right)^2} dx = \int_{\alpha}^{\beta} \sqrt{\left(\frac{dx}{d\theta}\right)^2 + \left(\frac{dy}{d\theta}\right)^2} d\theta . \text{ Changing the}$$

variable x to

$$\theta = \int_{\alpha}^{\beta} \sqrt{[f'(\theta)\cos\theta - f(\theta)\sin\theta]^2 + [f'(\theta)\sin\theta + f(\theta)\cos\theta]^2} d\theta$$

$$= \int_{\alpha}^{\beta} \sqrt{[f(\theta)^2 + (\theta)]^2} d\theta = \int_{\alpha}^{\beta} \sqrt{r^2 + \left(\frac{dr}{d\theta}\right)^2} d\theta$$

Example 3: To find the perimeter of the cardioids $r = a(1 + \cos \theta)$ we note that the curve is symmetrical about the initial line (Fig. 5). Therefore its perimeter is double the length of the arc of the curve lying above the x-axis.

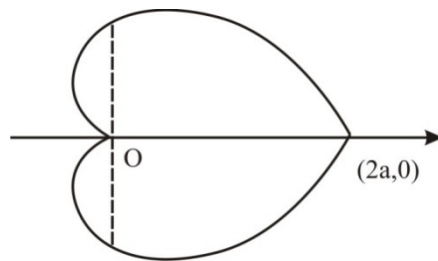

Fig.5

$$\text{Now, } \frac{dr}{d\theta} = -a \sin \theta. \text{ Hence, we have } L = 2 \int_0^{\pi} \sqrt{r^2 + \left(\frac{dr}{d\theta}\right)^2} d\theta =$$

$2a$

$$\int_0^{\pi} \sqrt{(1 + \cos \theta)^2 + \sin^2 \theta} d\theta = 2a \int_0^{\pi} \sqrt{2(1 + \cos \theta)} d\theta = 4a \int_0^{\pi} \cos \frac{\theta}{2} d\theta$$

$$= 4a \left[2 \sin \frac{\theta}{2} \right]_0^{\pi} = 8a$$

Table 1 : Length of an arc of a curve	
Equation of the Curve	Length L.
$y = f(x)$	$\int_a^b \sqrt{1 + f'(x)^2} dx$
$x = g(y)$	$\int_a^b \sqrt{1 + g'(y)^2} dy$
$x = \phi(t), y = \Psi(t)$	$\int_\alpha^\beta \sqrt{\phi'(t)^2 + \psi'(t)^2} dt$
$r = f(\theta)$	$\int_\alpha^\beta \sqrt{f(\theta)^2 + f'(\theta)^2} d\theta$

Check your progress

- (6) Find the length of the cycloid $x = a(\theta - \sin \theta)$; $y = a(1 - \cos \theta)$
- (7) Show that the length of the arc of the curve $x = e^t \sin t$, $y = e^t \cos t$ from $t = 0$ to $t = \pi/2$ is $\sqrt{2}(e^{\pi/2} - 1)$
- (8) Find the length of the curve $r = a \cos^3(\theta/3)$.
- (9) Find the length of the circle of radius 2 which is given by the equations $x = 2 \cos t + 3$, $y = 2 \sin t + 4$, $0 \leq t \leq 2\pi$.
- (10) Show that the arc of the upper half of the curve $r = a(1 - \cos \theta)$ is bisected by $\theta = 2\pi/3$
- (11) Find the length of the curve $r = a(\theta^2 - 1)$ from $\theta = -1$ to $\theta = 1$.

Solution and Answers of Check your Progress

$$(1) L = \int_c^d \sqrt{1 + [dx/dy]^2} dy = \int_1^2 \sqrt{1 + (3)^2} dy = \sqrt{10} \int_1^2 dy = \sqrt{10}$$

By distance formula,

$$L = \sqrt{(x_2 - x_1)^2 + (y_2 - y_1)^2} = \sqrt{(3 - 6)^2 + (1 - 2)^2}$$

$$= \sqrt{(-3)^2 + (-1)^2} = \sqrt{10}$$

(2)

$$L = \int_a^b \sqrt{1 + (dy/dx)^2} dx \left(\frac{dy}{dx} = \frac{1}{\sec x} \cdot \sec x \tan x = \tan x \right)$$

$$\begin{aligned}
&= \int_0^{\pi/3} \sqrt{1 + \tan^2 x} \, dx \\
&= \int_0^{\pi/3} \sec x \, dx = \ln|\sec x + \tan x|_0^{\pi/3} = \ln \left| \frac{\sec \pi/3 + \tan \pi/3}{\sec 0 + \tan 0} \right| \\
&= \ln(2 + \sqrt{3})
\end{aligned}$$

(3)

$$\begin{aligned}
L &= \int_0^x \sqrt{1 + \sinh^2(x/c)} \, dx = \int_0^x \cosh(x/c) \, dx \\
&= c \sinh(x/c) \Big|_0^x = c \sinh(x/c)
\end{aligned}$$

$$(4) \quad y = \sqrt{\frac{x^3}{a}} \therefore dy/dx = (3/20)\sqrt{\frac{x}{a}}$$

$$\begin{aligned}
L &= \int_0^a \sqrt{1 + \frac{9x}{4a}} \, dx = \frac{1}{2\sqrt{a}} \int_0^a \sqrt{4a + 9x} \, dx = \frac{1}{27\sqrt{a}} (4a + 9x)^{3/2} \Big|_0^a \\
&= \frac{1}{27\sqrt{a}} [13a]^{3/2} - (4a)^{3/2} = \frac{a}{27} (13^{3/2} - 8)
\end{aligned}$$

$$(5) \quad 3y = dx \Rightarrow y = \frac{8x}{3}. \text{ Substituting this in } y^2=4ax \text{ we get}$$

$$\frac{64x^2}{9} = 4ax$$

$$\text{i.e., } 64x^2 - 36ax = 0 \Rightarrow x = 0 \text{ or } x = \frac{9a}{16} \Rightarrow y = 0 \text{ or } y = \frac{3a}{2}$$

Hence $(0, 0)$ and $\left(\frac{9a}{16}, \frac{3a}{2}\right)$ are the points of intersection. Now $4ax =$

$$y^2 \Rightarrow \frac{dx}{dy} = \frac{y}{2a}$$

$$\begin{aligned}
L &= \int_0^{3a/2} \sqrt{1 + \frac{y^2}{4a^2}} \, dy = \frac{1}{2a} \int_0^{3a/2} \sqrt{4a^2 + y^2} \, dy \\
&= \frac{1}{2a} \left[\frac{y}{2} \sqrt{4a^2 + y^2} + 2a^2 \ln|y + \sqrt{4a^2 + y^2}| \right]_0^{3a/2} \\
&= \frac{1}{2a} \left[\frac{15a^2}{8} + 2a^2 \ln 2 \right] = \left(\frac{15}{16} + \ln 2 \right) 2
\end{aligned}$$

$$(6) \quad \frac{dx}{d\theta} = a(1 - \cos \theta), \frac{dy}{d\theta} = a \sin \theta$$

$$\therefore \left(\frac{dx}{d\theta}\right)^2 + \left(\frac{dy}{d\theta}\right)^2 = a^2[1 + \cos^2 \theta - 2 \cos \theta + \sin^2 \theta] = 2a^2(1 - \cos \theta)$$

$$= 4a^2 \sin^2(\theta/2) \quad \therefore L = 2a \int_0^{2\pi} \sin$$

$$(\theta/2)d\theta = 4a \int_0^{\pi} \sin \phi \, d\phi = 8a \int_0^{\pi/2} \sin \phi \, d\phi = 8a$$

$$(7) \quad \frac{dx}{dt} = e^t(\cos t + \sin t), \frac{dy}{dt} = e^t(\cos t - \sin t)$$

$$\therefore \left(\frac{dx}{dt}\right)^2 + \left(\frac{dy}{dt}\right)^2 = 2e^{2t} \therefore L = \sqrt{2} \int_0^{\pi/2} e^t dt \sqrt{2e^t} \Big|_0^{\pi/2} = \sqrt{2}(e^{\pi/2} - 1)$$

$$(8) \quad r = a \cos^3 \frac{\theta}{3} \Rightarrow \frac{dr}{d\theta} = -a \cos^2 \frac{\theta}{3} \sin \frac{\theta}{3}$$

$$\therefore r^2 + \left(\frac{dr}{d\theta}\right)^2 = a^2 \cos^6 \frac{\theta}{3} + a^2 \cos^4 \frac{\theta}{3} \sin^2 \frac{\theta}{3} = a^2 \cos^4 \frac{\theta}{3}$$

$$\therefore L = 2a \int_0^{3\pi/2} \cos^2 \frac{\theta}{3} d\theta = 6a \int_0^{\pi/2} \cos^2 \phi \, d\phi = \frac{3a\pi}{2}$$

(9)

$$\frac{dx}{dt} = -2 \sin t, \frac{dy}{dt} = 2 \cos t$$

$$\therefore \sqrt{\left(\frac{dx}{dt}\right)^2 + \left(\frac{dy}{dt}\right)^2} = 2\sqrt{\sin^2 t + \cos^2 t} = 2$$

$$\therefore L = 2 \int_0^{2\pi} dt = 4\pi \text{ Note that } L = 2\pi r \text{ since, here, } r = 2$$

$$(10) \quad r = a(1 - \cos \theta), \frac{dr}{d\theta} = a \sin \theta \therefore \sqrt{r^2 + \left(\frac{dr}{d\theta}\right)^2} = 2a \sin \frac{\theta}{2}$$

$$\text{The length of the curve in the upper half} = \int_0^{\pi} 2a \sin(\theta/2) d\theta$$

The length from $\theta = 0$ to $\theta = 2\pi/3$

$$(11) \quad r = a(\theta^2 - 1), \quad \frac{dr}{d\theta} = 2a\theta, \quad r^2 + \left(\frac{dr}{d\theta}\right)^2 = a^2 [\theta^4 - 2\theta^2 + 1 + 4\theta^2] = a^2 (\theta^2 + 1)^2.$$

$$\therefore L = a \int_{-1}^1 (\theta^2 + 1)^2 d\theta = a \left[\frac{\theta^3}{3} + \theta \right]_{-1}^1 = a \left(\frac{1}{3} + 1 + \frac{1}{3} + 1 \right) = \frac{8a}{3}$$

6.6 Summary

In this Unit, area of a curve in Cartesian form, in polar form and in parametric form is discussed. Area bounded by a closed curve, area common to two given curves, length of a plane curves in Cartesian form, in polar form and in parametric form from a given point to another given point s discussed.

6.7 Terminal Questions

1. Find the whole area of the curve

$$a^2 y^2 = x^3. (2a - x) \quad (\text{Answer: } \pi a^2)$$

2. Trace the curve $a^2 y^2 = a^2 x^2 - x^4$ and find the whole area within it .

3. Find the common area of the curves

$$y^2 = ax \quad \& \quad x^2 + y^2 = 4ax. \quad (\text{Ans: } \frac{1}{3} (a\sqrt{3} + 4\pi) a^2)$$

4. Find the area bounded by the curve

$$y = a(1 + \cos\theta). \quad (\text{Ans: } \frac{3\pi}{2} a^2)$$

5. Find the area bounded by the curve

$$r^2 = a^2 \cos^2 \theta + b^2 \sin^2 \theta \quad (\text{Ans: } \frac{\pi}{2} (a^2 + b^2))$$

6. Find the length of the arc of semicubical parabola $ay^2 = x^2$ from the vertex to the point (a, a).

$$(\text{Ans: } \frac{1}{27} \{13\sqrt{13} - 8\} a.)$$

7. Find the length of the arc of the cycloid $x=a(t-\sin t)$, $y=a(1-\cos t)$
(Ans: $8a$)

8. Find the length of the arc of equiangular spiral $r = ae^{\theta \cot \alpha}$ between the point for which the radii vectors are r_1 & r_2 .

$$(\text{Ans: } (r_2 - r_1) \sec \alpha)$$

RIL-146

UGMM-103/158

UNIT-7

VOLUME OF A SOLID OF REVOLUTION

Structure

- 7.1 Introduction
 - Objective
- 7.2 Volume of A solid of Revolution
 - 7.2.1 Cartesian Form
 - 7.2.2 Parametric Form
 - 7.2.3 Polar form
- 7.3 Area of Surface of Revolution
 - 7.3.1 Cartesian Form
 - 7.3.2.1 Parametric Form
 - 7.3.2.2 Polar form
- 7.4 Summary
- 7.5 Terminal Questions

7.1 Introduction

In the last unit we have seen how definite integrals can be used to calculate areas. In fact, this application of definite integrals is not surprising. Because, as we have seen earlier, the problem of finding areas was the motivation behind the definition of integrals. In this unit we shall see that the length of an arc of a curve, the volume of a cone and other solids of revolution, the area of a sphere and other surfaces of revolution, can all be expressed as definite integrals. This unit also brings us to the end of this course on calculus.

Objective

- Find the volumes of some solids of revolution
- Find the areas of some surfaces of revolution

7.2 Volume of A solid of Revolution

In this unit, we were concerned with only plane curves and regions. In this section we shall see how our knowledge of integration can

be used to find the volume of certain solids. Look at the plane region in Fig. 6(a). it is bounded by $x = a$, $x = b$, $y = f(x)$ and the x -axis. If we rotate this plane region about the x -axis, we get a solid. See Fig. 6(b) .

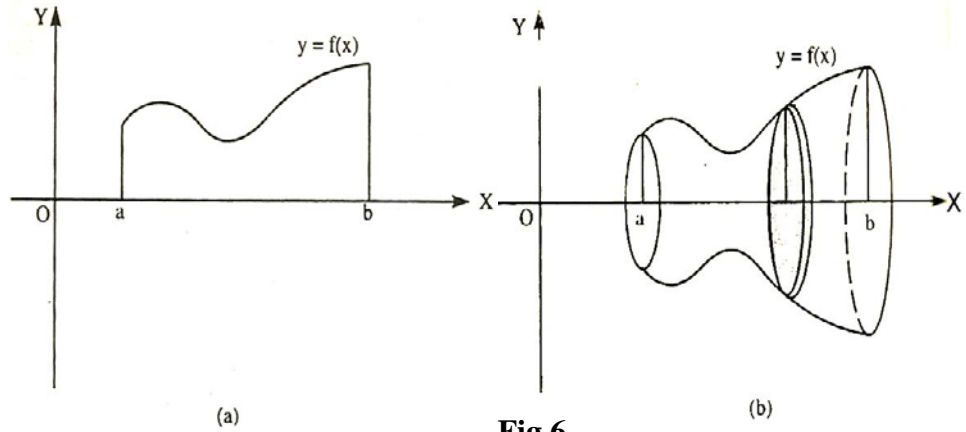

Fig.6

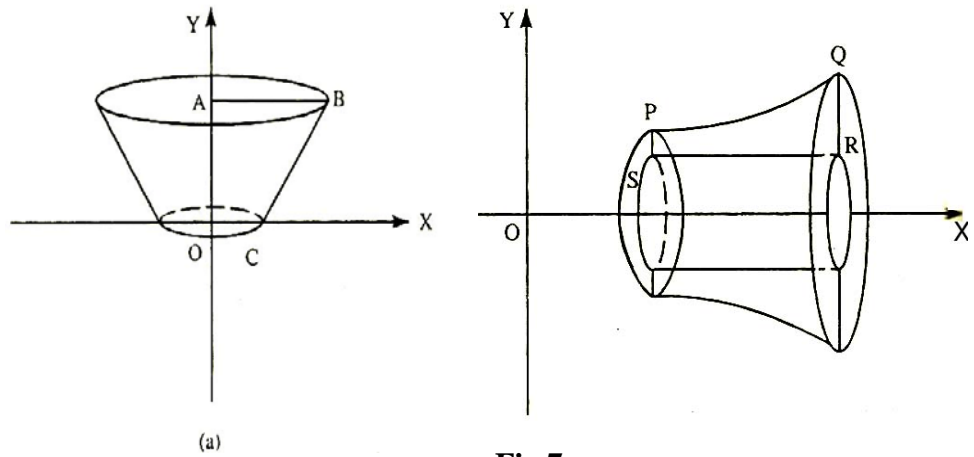

Fig.7

The solid in Fig. 7(a) is obtained by revolving the region ABCO around the y -axis. The solid of revolution in Fig. 7(b) differs from the others in that its axis of rotation does not form a part of the boundary of the plane region of PQRS which is rotated. We see many examples of solids of revolution in every day life. The various kinds of post made by a potter using his wheel are solids of revolution. See Fig. 8(a). Some objects manufactured with the help of lathe machine are also solids of revolution. See Fig. 8 (b).

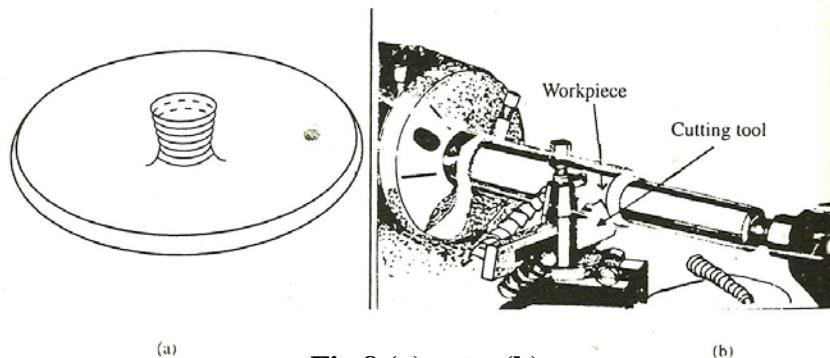

Fig.8 (a) (b)

Now, let us try to find the volume of solid of revolution. The method which we are going to use is called the method of slicing. The reason for this will be clear in a few moments.

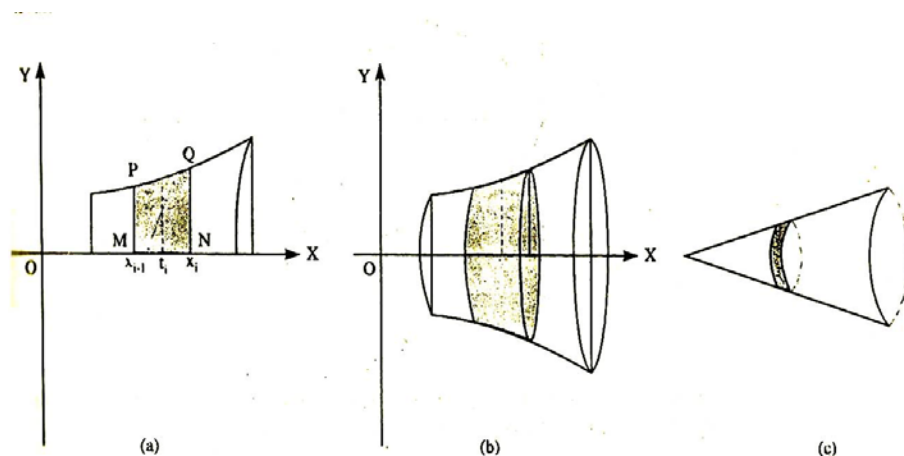

Fig.9

Let Δx_i denote the length of the i th sub-interval $[x_{i-1}, x_i]$. Further, let P and Q be the points on the curve, $y = f(x)$ corresponding to the ordinates $x = x_{i-1}$ and $x = x_i$ respectively. Then, as the curve revolves about the x-axis, the shaded strip PQNP (Fig. 9(a)) generates a disc of thickness Δx_i . In general, the ordinates PM and QN may not be of equal length. Hence, the disc is actually the frustum of a cone with its volume Δv_i , lying between πPM^2MN and πQN^2MN , that is between $\pi[f(x_{i-1})]^2 \Delta x_i$ and $\pi[f(x_i)]^2 \Delta x_i$ [Fig. 9(b) and (c)]

If we assume that f is a continuous function on $[a, b]$, we can apply the intermediate value theorem and express this volume as $\Delta v_i = \pi \{f(t_i)\}^2 \Delta x_i$, where t_i is a suitable point in the interval $[x_{i-1}, x_i]$. Now summing up over all the discs, we obtain

$$V_a = \sum_{i=1}^n \Delta v_i = \sum_{i=1}^n \pi [f(t_i)]^2 \Delta x_i \quad x_{i-1} \leq t_i \leq x_i \text{ as an approximation}$$

As we have observed earlier while defining a definite integral, the approximation gets better as the partition P_n gets finer and finer and Δx_i tends to zero. Thus, we get the volume of the solid of revolution as

$$V = \lim_{n \rightarrow \infty} V_n = \lim_{n \rightarrow \infty} \sum_{i=1}^n \pi [f(t_i)]^2 \Delta x_i, \quad V = \pi \int_a^b [f(x)]^2 dx = \pi \int_a^b y^2 dx \quad \dots(6)$$

Example 1: Let us find the volume of the solid of revolution formed when the arc of the revolution $y^2 = 4ax$ between the ordinates $x = 0$, and $x = a$ is revolved about its axis. The solid of the volume V of the cap is given by

$$V = \int_0^a \pi y^2 dx = \pi \int_0^a 4ax dx = 4\pi a \left[\frac{x^2}{2} \right]_0^a = 2\pi a^3$$

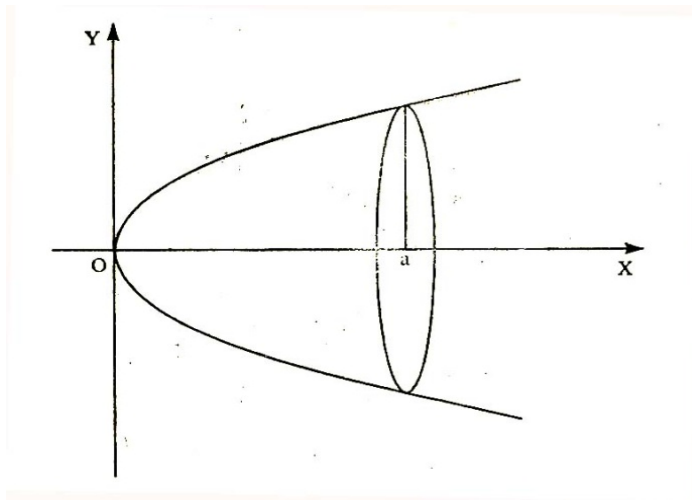

Fig. 10

Our next example illustrates a slight modification of Formula (6) to find the volume of a solid obtained by revolving a plane region about the y-axis.

Example2: Suppose the ellipse $\frac{x^2}{a^2} + \frac{y^2}{b^2} = 1, (a > b)$ is revolved about the minor axis, AB (see Fig. 11). Let us find the volume of the solid generated.

In this case the axis of rotation is the y-axis. The area revolved about the y-axis is shown by the shaded region in Fig. 11. You will agree that we need to consider only the area to the right of the y-axis.

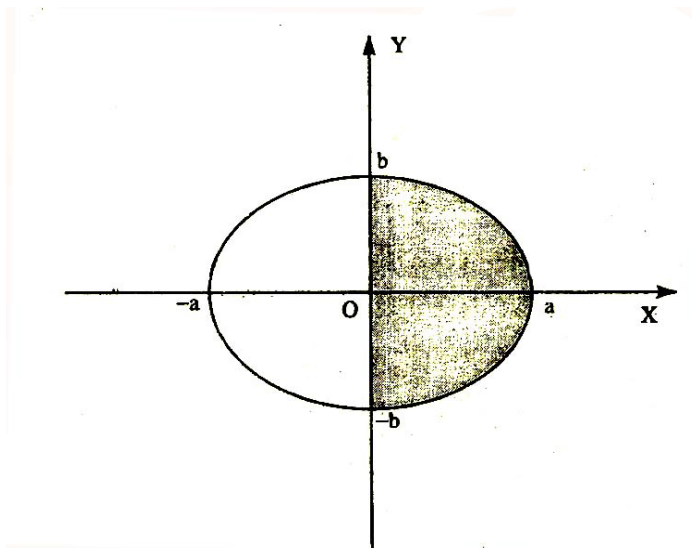

Fig.11

To find the volume of this solid we interchange x and y in (6) and get

$$\begin{aligned}
 V &= \int_{-b}^b \pi x^2 dy = \int_{-b}^b \pi a^2 \left(1 - \frac{y^2}{b^2}\right) dy, \text{ since } x^2 = a^2 \left(1 - \frac{y^2}{b^2}\right) \\
 &= 2\pi a^2 \int_0^b \left(1 - \frac{y^2}{b^2}\right) dy, \text{ (since } 1 - \frac{y^2}{b^2} \text{ is an even function of } y) \\
 &= 2\pi a^2 \left[y - \frac{y^3}{3b^2} \right]_0^b = \frac{4}{3} \pi a^2 b.
 \end{aligned}$$

We can also modify formula (6) to apply to curves whose equations are given in the parametric or polar forms. Let us tackle these one by one.

7.2.2 Parametric Form

If a curve is given by $x = \phi(t)$, $y = \Psi(t)$, $\alpha \leq t \leq \beta$, then the volume of the solid of revolution about the x-axis can be found by substituting x and y in

formula (6) by $\phi(t)$ and $\Psi(t)$, respectively. Thus, $V = \pi \int_{\alpha}^{\beta} [\Psi(t)]^2 \frac{dx}{dt} dt$

$$\text{or } V = \pi \int_{\alpha}^{\beta} [\Psi(t)]^2 \phi'(t) dt$$

we'll now derive the formula for curves given by polar equations.

7.2.3 Polar Form

Suppose a curve is given by $r = f(\theta)$, $\theta_1 \leq \theta \leq \theta_2$. The volume of the solid generated by rotating the area bounded by $x = a$, $x = b$, the x-axis and $r =$

$f(\theta)$ about the axis is $V = \pi \int_{\theta_1}^{\theta_2} (r \sin \theta)^2 \frac{d}{d\theta} (r \cos \theta) d\theta$. Thus,

$$V = \pi \int_{\theta_1}^{\theta_2} [f(\theta) \sin \theta]^2 [f'(\theta) \cos \theta - f(\theta) \sin \theta] d\theta$$

Let's use this formula to find the volume of the solid generated by a cardioid about its initial line.

Example 3: The cardioid shown in Fig. 12 is given by $r = a(1 + \cos \theta)$.

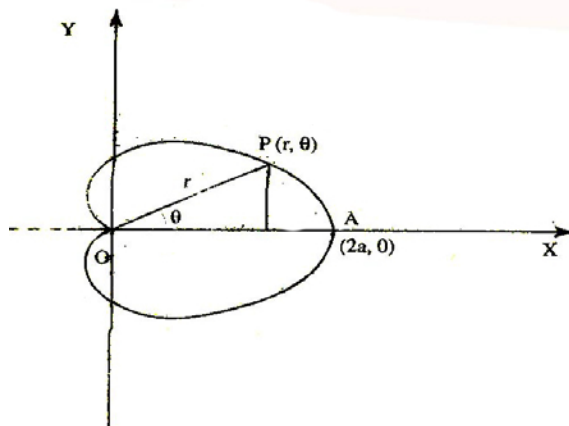

Fig. 12

The points A and O correspond to $\theta = 0$ and $\theta = \pi$, respectively. Here, again, we need to consider only the part of the cardioids above the initial line. Thus,

$$\begin{aligned}
 V &= \int_{\pi}^0 \pi (r \sin \theta)^2 \frac{d}{d\theta} (r \cos \theta) d\theta \\
 &= \pi a^3 \int_0^{\pi} (1 + \cos \theta)^2 \sin^3 \theta (1 + 2 \cos \theta) d\theta, \text{ since } r = a (1 + \cos \theta) \\
 &= \pi^3 \int_0^{\pi} 8 \sin^3 \frac{\theta}{2} \cos^3 \frac{\theta}{2} 4 \cos \frac{\theta}{2} \left(4 \cos^2 \frac{\theta}{2} - 1 \right) d\theta \\
 &= 128 \pi a^3 \int_0^{\pi} \sin^3 \frac{\theta}{2} \cos^9 \frac{\theta}{2} d\theta - 32 \pi a^3 \int_0^{\pi} \sin^3 \frac{\theta}{2} \cos^7 \frac{\theta}{2} d\theta \\
 &= 256 \pi a^3 \int_0^{\pi/2} \sin^3 \phi \cos^9 \phi d\phi - 32 \pi a^3 \int_0^{\pi/2} \sin^3 \phi \cos^7 \phi d\phi, \text{ where } \phi = \theta/2. \\
 &= \frac{64 \pi a^3}{15} - \frac{8 \pi a^3}{5} \text{ on applying a reduction formula.}
 \end{aligned}$$

In all the example that we have seen till now, the axis of rotation formed a boundary of the region which was rotated. Now we take an example in which the axis touches the region at only one point.

Example 4: Let us find the volume of the solid generated by revolving the region bounded by the parabolas $y = x^2$ and $y^2 = 8x$ about the x-axis. We have shown the area rotated and the solid

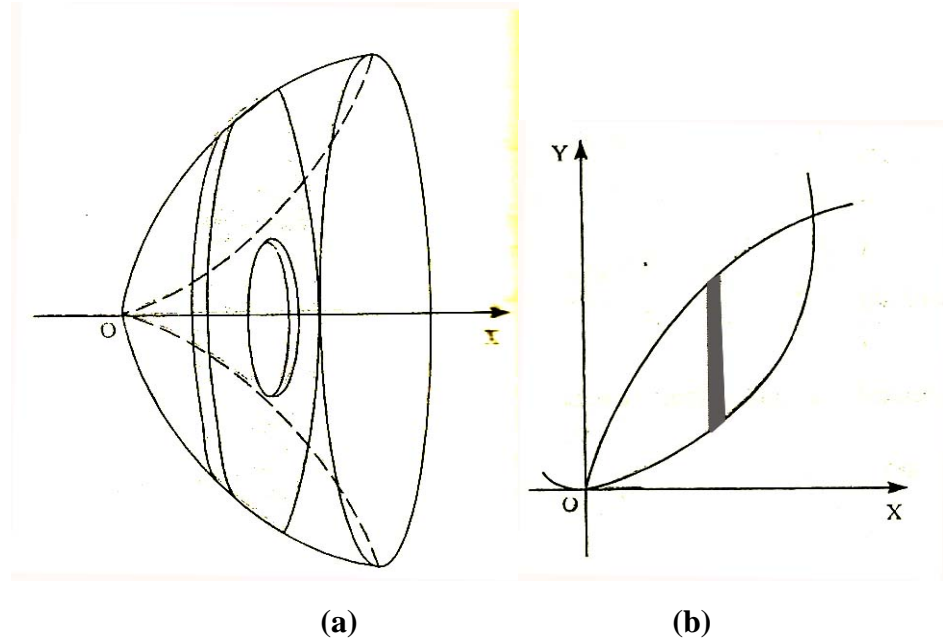

Fig. 13

Here, the required volume will be the difference between the volume of the solid generated by the parabola $y^2 = 8x$ and that of the solid generated by the parabola

$$y = x^2. \text{ Thus } V = \pi \left[\int_0^2 8x \, dx - \int_0^2 x^4 \, dx \right] = \pi \left[4x^2 - \frac{x^5}{5} \right]_0^2 = \frac{48\pi}{5}$$

Check your progress

- (1) Find the volume of the right circular cone of height h and radius of the circular base t . (Hint.: The cone will be generated by rotating the triangle bounded by the x -axis and the line $y = (t/h)x$).
- (2) Show that the volume of the solid generated by revolving the curve $x^{2/3} + y^{2/3} = a^{2/3}$ about the x -axis is $32\pi a^3/105$.
- (3) The arc of the cycloid $x = a(t - \sin t)$, $y = a(1 - \cos t)$ in $[0, 2\pi]$ is rotated about the y -axis. Find the volume generated. (Hint: the rotation is about the y -axis).
- (4) Find the volume of the solid obtained by revolving the limaçon $r = a + b \cos \theta$ about the initial line.
- (5) The semicircular region bounded by $y - 2 = \sqrt{9 - x^2}$ and the line $y = 2$ is rotated about the x -axis. Find the volume of the solid generated.

7.3 Area of Surface of Revolution

Instead of rotating a plane region, if we rotate a curve about an x -axis, we shall get a surface of revolution. In this section we shall find a formula for the area of such a surface. Let us start with the case when the equation of the curve is given in the Cartesian form.

7.3.1 Cartesian Form

Suppose that the curve $y = f(x)$ [Fig. 14] is rotated about the x -axis. To find the area of the area of the generated surface, we consider a partition P_n of the interval $[a, b]$, namely, $P_n = \{a = x_0 < x_1 < x_2 < \dots < x_{n-1} < x_n = b\}$

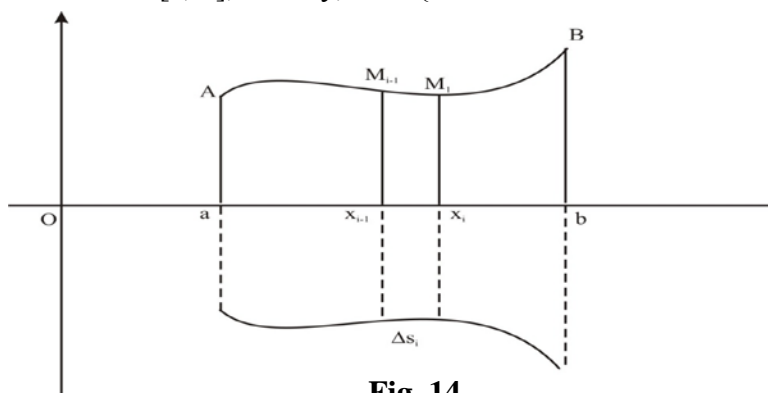

Fig. 14

Let the lines $x = x_i$ intersect the curve in points $M_i, i = 1, 2, \dots, n$. If we revolve the chord $M_{i-1}M_i$ about the x -axis, we shall get the surface of the frustum of a cone of thickness $\Delta x_i = x_i - x_{i-1}$. Let Δs_i be the area of the area of the surface of this frustum. Then the total surface area of all the frusta is

$$S_n = \sum_{i=1}^n \Delta s_i$$

This S_n is approximation to the area of the surface of revolution. The area of the surface of revolution generated by the curve $y = f(x)$, is the limit of S_n (if it exist), as $n \rightarrow \infty$ and each $\Delta x_i \rightarrow 0$.

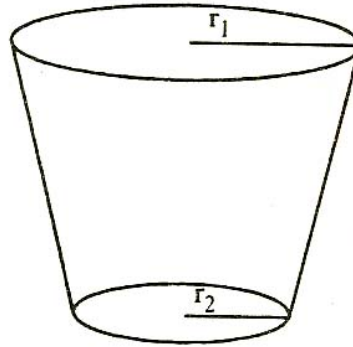

Fig. 15

To find the area A of the curved surface of a typical frustum, we use the formula $A = \pi (r_1 + r_2) l$, where l is that slant height of the frustum and r_1 and r_2 are the radii of its bases (Fig. 15).

In the frustum under consideration the radii of the bases are the ordinates $f(x_{i-1})$ and $f(x_i)$. We assume that f is derivable on $[a, b]$ and f' is continuous. Then by the mean value theorem we obtained $\Delta y_i = f'(t_i) \Delta x_i$,

$$\text{for some } t_i \in [x_{i-1}, x_i]. \Delta s_i = 2\pi \frac{[f(x_{i-1}) + f(x_i)]}{2} \sqrt{(\Delta x_i)^2 + (\Delta y_i)^2}$$

where $f(x_{i-1}) + f(x_i)/2$ is the mean radius of revolution

$$= 2\pi \frac{y_{i-1} + y_i}{2} \sqrt{1 + [f'(t_i)]^2} \Delta x_i \quad \text{and}$$

$$S_n = 2\pi \sum_{i=1}^n \frac{y_{i-1} + y_i}{2} \sqrt{1 + [f'(t_i)]^2} \Delta x_i$$

Proceeding to the limit as $n \rightarrow \infty$, and each $\Delta x_i \rightarrow 0$, we have

$$S = 2\pi \int_a^b f(x) \sqrt{1 + [f'(x)]^2} dx$$

∴ in the lim $\Delta x_i \rightarrow 0$, $y_i \rightarrow f(x)$, $\rightarrow f(x)$, $y_{i-1} \rightarrow f(x)$ and $f'(t_i) \rightarrow$

$$f(x) = 2\pi \int_a^b y \sqrt{1 + (dy/dx)^2} dx$$

Example 5 : Let us find the area of the surface of revolution obtained by revolving the parabola $y^2 = 4ax$ from $x = a$ to $x = 3a$, about the x-axis.

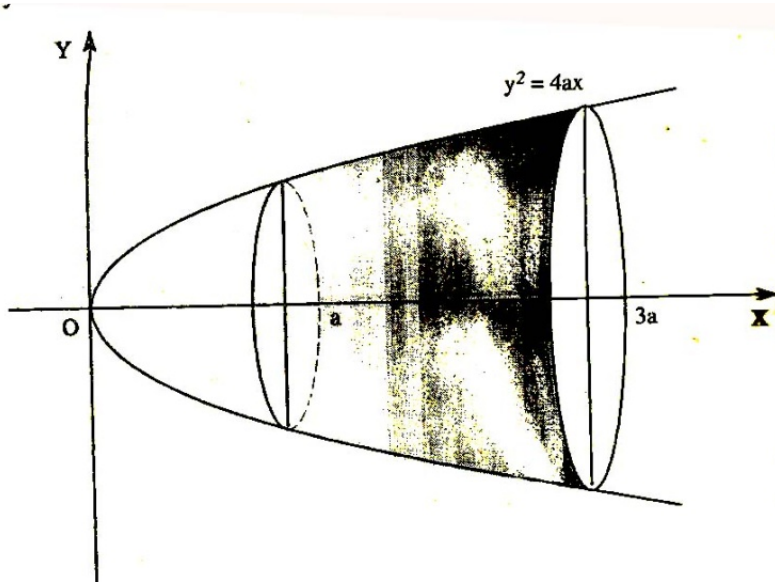

Fig. 16

The area of the surface of revolution. $S = 2\pi \int_a^{3a} y \sqrt{1 + \left(\frac{dy}{dx}\right)^2} dx$.

where $y^2 = 4ax$, $\frac{dy}{dx} = \frac{2a}{y}$. Hence, $S = 2\pi \int_a^{3a} y \sqrt{1 + 4a^2 / y^2} dx$

$$= 2\pi \int_a^{3a} \sqrt{y^2 + 4a^2} dx = 2\pi \int_a^{3a} \sqrt{4ax + 4a^2} dx$$

$$= 4\pi\sqrt{a} \int_a^{3a} \sqrt{x+a} dx = 4\pi\sqrt{a} \frac{2}{3} [(x+a)^{3/2}]_a^{3a}$$

$$= \frac{8\pi a^2}{3} [4^{3/2} - 2^{3/2}]$$

Instead of revolving the given curve about the x-axis, if we revolve it about the y-axis, we get another surface of revolution. The area of the surface of revolution generated by the curve $x = g(y)$, $c \leq y \leq d$, as it

revolves about the y-axis is given by, $S = 2\pi \int_c^d x \sqrt{1 + (dx/dy)^2} dy$

7.3.2 Parametric Form

Suppose a curve is given by the parametric equations $x = \phi(t)$, $y = \Psi(t)$, $t \in [\alpha, \beta]$. Then $\frac{dy}{dx} = \frac{\Psi'(t)}{\phi'(t)}$

Substituting this in formula (10), we get the area of the surface of revolution generated by the curve as it revolves about the x-axis, to be

$$S = 2\pi \int_{\alpha}^{\beta} \Psi(t) \sqrt{[\phi'(t)]^2 + [\Psi'(t)]^2} dt$$

7.3.3 Polar form

If $r = h(\theta)$ is the polar equation of the curve, then the area of the surface of revolution generated by the arc of the curve for $\theta_1 \leq \theta \leq \theta_2$, as it revolves

about the initial line, is $S = 2\pi \int_{\theta_1}^{\theta_2} r \sin \theta \sqrt{r^2 + (dr/d\theta)^2} dt$

Example 6: Suppose the asteroid $x = a \sin^3 t$, $y = a \cos^3 t$, is revolved about the x-axis. Let us find the area of the surface of revolution. You will agree that we need to consider only the portion of the curve above the x-axis.

For this portion $y > 0$, and thus t varies from $-\pi/2$ to $\pi/2$.

$$\frac{dx}{dt} = 3a \sin^2 t \cos t, \quad \frac{dy}{dt} = -3a \cos^2 t \sin t$$

Therefore, $\left(\frac{dx}{dt}\right)^2 + \left(\frac{dy}{dt}\right)^2 = 9a^2 \sin^2 t \cos^2 t$. We therefore get,

$$\begin{aligned} S &= 2\pi \int_{-\pi/2}^{\pi/2} a \cos^3 t \sqrt{9a^2 \sin^2 t \cos^2 t} dt \\ &= 2\pi \int_{-\pi/2}^{\pi/2} a \cos^3 t |3a \sin t \cos t| dt \\ &= 6\pi a^2 \int_{-\pi/2}^{\pi/2} a \cos^3 t |\sin t| dt \\ &= 12\pi a^2 \int_0^{\pi/2} \cos^4 t \sin t dt = -12\pi a^2 \left| \frac{\cos^5 t}{5} \right|_0^{\pi/2} = \frac{12}{5} \pi a^5 \end{aligned}$$

Example 7: suppose we want to find the area of the surface generated by revolving the cardioid $r = a(1 + \cos \theta)$ about its initial line.

Notice that the cardioid is symmetrical about the initial line, and extends above this line from $\theta = 0$ to $\theta = \pi$. The surface generated by revolving the

whole curve about the initial line is the same as that generated by the upper half of the curve. Hence.

$$S = 2\pi \int_0^{\pi} r \sin \theta \sqrt{r^2 + (dr/d\theta)^2} d\theta$$

$$= 2\pi \int_0^{\pi} a(1 + \cos \theta) \sin \theta \sqrt{r^2 + (dr/d\theta)^2} d\theta$$

Since $r = a(1 + \cos \theta)$, and $\frac{dr}{d\theta} = -a \sin \theta$, we have

$$r^2 + \left(\frac{dr}{d\theta}\right)^2 = a^2(1 + \cos \theta)^2 + a^2 \sin^2 \theta = 4a^2 \cos^2 \frac{\theta}{2}$$

Therefore,

$$S = 2\pi \int_0^{\pi} a(1 + \cos \theta) \sin \theta 2a \cos \frac{\theta}{2} d\theta = 4\pi a^2 \int_0^{\pi} 4 \sin \frac{\theta}{2} \cos^4 \frac{\theta}{2} d\theta$$

$$= 32\pi a^2 \int_0^{\pi/2} \sin \phi \cos^4 \phi d\phi, \quad \text{where } \phi = \theta/2$$

$$= 32\pi a^2 \left[\frac{-\cos^5 \phi}{5} \right]_0^{\pi/2} = \frac{32\pi a^2}{5}$$

Check your progress

- (1) Find the area of the surface generated by revolving the circle $r = a$ about the x-axis thus verify that the surface area of a sphere of radius a is $4\pi a^2$.
- (2) The arc of the curve $y = \sin x$, from $x = 0$ to $x = \pi$ is revolved about the x-axis. Find the area of the surface of the solid of revolution generated.
- (3) The ellipse $x^2/a^2 + y^2/b^2 = 1$ revolves about the x-axis. Find the area of the surface of the solid of revolution thus obtained.
- (4) Prove that the surface of the solid generated by the revolution about the x-axis of the loop of the curve $x = t^2$, $y = \left(t - \frac{t^3}{3}\right)$ is 3π .
- (5) Find the surface area of the solid generated by revolving the cycloid $x = a(\theta - \sin \theta)$, $y = a(1 - \cos \theta)$, about the line $y = 0$.

7.4 Summary

In this unit we have seen how to find

- (1) The lengths of curves
- (2) Volumes of solids of revolution and
- (3) The areas of surfaces of revolution

In each case we have derived formulas when the equation of the curve is given in either the cartesian or parametric or polar form. We give the results here in the form of the following tables

Length of an arc of a curve	
Equation	Length
$y = f(x)$	$\int_a^b \sqrt{1 + [f'(x)]^2} dx$
$x = g(y)$	$\int_c^d \sqrt{1 + [g'(y)]^2} dy$
$x = \phi(t)$ $y = \Psi(t)$	$\int_\alpha^\beta \sqrt{[\phi'(t)]^2 + [\psi'(t)]^2} dy$
$r = f(\theta)$	$\int_\alpha^\beta \sqrt{[f(\theta)]^2 + [f'(\theta)]^2} d\theta$

Volume of the solid of revolution	
Equation	Volume
$y = f(x)$ about x –axis	$\pi \int_a^b y^2 dx$
$x = g(y)$ about y – axis	$\pi \int_c^d y^2 dx$
$x = \phi(t), y = \Psi(t)$ about x – axis	$\pi \int_a^b [\psi(t)]^2 \phi'(t) dt$
$r = h(\theta)$ about the initial line	$\pi \int_{\theta_1}^{\theta_2} [h(\theta) \sin \theta]^2 [h'(\theta) \cos \theta - h(\theta) \operatorname{sinc} \theta] d\theta$

Area of the surface of revolutions	
Equation	Area
$y = f(x)$ about x –axis	$2\pi \int_a^b f(x) \sqrt{1 + [f'(x)]^2} dx$
$x = g(y)$ about y – axis	$2\pi \int_c^d x(y) \sqrt{1 + [g'(y)]^2} dy$
$x = \phi(t), y = \Psi(t)$ about x – axis	$2\pi \int_\alpha^\beta \psi(t) \sqrt{[\phi'(t)]^2 + [\psi'(t)]^2} dt$
$r = h(\theta)$ about the initial line	$2\pi \int_{\theta_1}^{\theta_2} r \sin \theta \sqrt{r^2 + (dr/d\theta)^2} d\theta$

7.5 Terminal Questions

- Find the volume of the paraboloid generated by the revolution about X- axis of the parabola $y^2 = 4ax$ from $x=0$ to $x=h$.

$$(Ans: 2\pi ah^2)$$

- Find the volume of the spherical cap of height h cut off from a sphere of radius a .

$$(Ans \pi h^2 (a - \frac{1}{3} h))$$

- Find the volume of the solid generated by revolving the ellipse $\frac{x^2}{a^2} + \frac{y^2}{b^2} = 1$ about X-axes

$$(Ans \frac{4}{3} \pi ab^2)$$

- Find the volume when part of the ellipse $\frac{x^2}{a^2} + \frac{y^2}{b^2} = 1$ cut of by a latusrectum revolves about the tangent at the nearest vertex .

$$(Ans \frac{2\pi b}{3a} \left\{ 6a^2b - b^2 - 3ab\sqrt{a^2 - b^2} - 3a^2 \cdot \sin^{-1} \frac{b}{a} \right\})$$

NOTE